

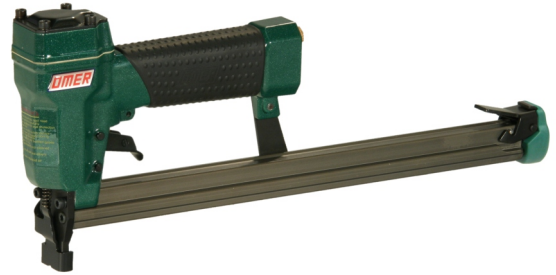

Manuale d'uso, manutenzione e parti di ricambio **Parte 2**
Use, maintenance and spare parts manual **Part 2**
Gebrauchsanweisung, Instandhaltungsrichtlinien und Ersatzteile **Teil 2**
Manuel d'utilisation, entretien et pièces de rechange **Partie 2**
Manual de uso, mantenimiento y repuestos **Part 2**
 Εγχειρίδιο χρήσης, συντηρησης και ανταλλακτικών **2° Μέρος**
Manual de utilização, manutenção e partes sobresselentes **Parte 2**
Handleiding voor gebruik, onderhoud en reservedelslste **Deel 2**
Brugsanvisning, vedligeholdelse og reservedelslste **Del 2**



81P SCL

cod. 11461690



11461690_81PSCL_6 290515 IV

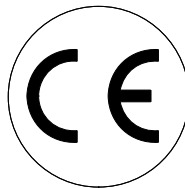

Dati tecnici Technical data Technische daten	Données techniques Datos tècnicos Τεχνικά χαρακτηριστικά	Dados tècnicos Technische gegevens Tecniske data
Misure impiegabili mm Usable lengths mm Gebrauchliche Längen mm	Mesures utilisable mm Medidas que se pueden emplear mm Διαστάσεις σε μμ	Medidas que se podem utilizar mm Te gebruiken engtes in mm Brugbare længder i mm
Capacità caricatore n° punti Magazine capacity No. of fasteners Magazinkapazität Nägel	Capacité chargeur n° de points Capacidad cargador n° puntos Δυνατότητα γεμιστέρα, σπινδότερες	Capacidade carregador n° pontos Capaciteit magazijn in aantal spijkers Kapacitet af magasin antal klemmme
Pressione d'esercizio Working pressure Betriebsdruck	Pression de fonctionnement Presión de trabajo Πίεση λειτουργίας ατμ.	Pressao de trabalho Werkdruk Arbejds tryk bar
Consumo aria litri/colpo Air consumption litres/shot Luftverbrauch Liter/Schlag	Consommation air litre/coup Consumo aire-litros/golpe Κατανάλωση αερα λξτππημα	Consumo ar litro/golpe Luchtverbruik liter/schot Luftforbrug liter/skud
Peso kg Weight kg Gewicht kg	Poids kg Peso kg Βαρος κγ	Peso kg Gewicht in kg Vaegt kg
Dimensioni (AxBxH) mm Dimensions mm Größe mm	Dimension mm Dimensiones mm Δυνατότητα γεμιστέρα, σπινδότερες	Dimencoes mm Afmetingen in mm Dimensioner mm
EN 12549 :1999 ISO 11201 :1995		
Pressione sonora in pos. operatore Sound pressure at the workstation Lärmintensität am Arbeitsplatz	Pression acoustique près de l'opérateur Presión sonora en posición encargado Ακουστική πίεση στη θέση χειριστού	Intensidade sonora perto do operador Geluidssterkte op de werkplek Lydstyrke på operatorposten
EN 12549 :1999 ISO 3744 :1994		
Potenza sonora emessa Emitted sound power Ausgestrahlte Lärmintensität	Puissance acoustique émise Potencia sonora emitida Ακουστική ισχυ	Potência sonora emitida Uitgestraalde geluidssterkte Udsendt lydstyrke
EN 28662 :1992 ISO 5349 :1986 ISO 8662 -11		
Valore medio ponderato di vibrazione sull'impugnatura max.33 colpi Weighted mean value of vibration on the grip max.33 shots Mittlerer Vibrationswert, am Griff gemessen max.33 Schläge	Valeur moyenne pondérée de vibration mesurée sur la poignée max.33 coups Valor medio ponderado de vibracion medida en la empuñadura max.33 golp Μεσοσ ορος μετρησις κραδασιμον στη χειρολαβη μαξ.33 ξτππημα	Valor medio ponderado de vibracao medida no punho max.33 golpes Gewogen gemiddelde vibratiewaarde max.33 schot Middelvaerdi af vibrationer pa handtaget max.33 skud

Tipo di punto
 Type of fastener
 Befestigungselement
 Type d'agrafe
 Tipo de punto
 Τυπος καρφίτου
 Tipo de ponto
 Type nietjes
 Tilspændingstype

81P

1,10x1,25

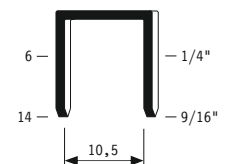

Crown: .500" (1/2")
 Thickness: .043"
 Width: .050"
 Gauge: 19

Parti di ricambio - Spare parts - Ersatzteile - Pièces de rechange - Piezas de repuesto
 Ανταλλακτικά - Partes sobresselentes - Tabel te raadplegen - Reservedele

Cod.	Descrizione	Description
00.04	O-Ring	O-Ring
00.06	O-Ring	O-Ring
00.12	O-Ring	O-Ring
00.13	O-Ring	O-Ring
00.14	O-Ring	O-Ring
00.26	O-Ring	O-Ring
00.27	O-Ring	O-Ring
00.35	O-Ring	O-Ring
01.21.1	Guarnizione	Gasket
01.21.3	Guarnizione	Gasket
01.29	O-Ring	O-Ring
01.33	O-Ring	O-Ring
04.06.5	Vite	Screw
04.10	Vite	Screw
04.12	Vite	Screw
04.14	Vite	Screw
04.20	Vite	Screw
04.35	Vite	Screw
07.30	Chiave esagonale	Hex. bar wrench
09.02	Anello elastico	Elastic ring
09.14	Rondella	Washer
14.18.1	Spina	Pin
20.00	Corpo	Body
22.07	Testa	Head
24.00	Silenziatore	Silencer
25.04	Deflettore	Exhaust deflector
26.07	Cilindro	Cylinder
28.00	Guarnizione	Gasket
30.07.3	Pistone	Piston
32.05	Ammortizzatore	Bumper
39.00	Guarnizione scarico	Exhaust gasket
40.04.2	Valvola completa	Valve ass'y
45.04	Anello valvola	Ring
50.03	Pulsante completo	Trigger valve ass'y
52.02	Boccola	Bush
54.04	Pulsante	Trigger valve
55.06.1	Raccordo	Bush
70.04	Protezione	Guard
72.03.1	Reggicaricatore	Support
72.06	Fermo carrello	Slider stop
75.04	Sicura	Safety
76.04	Perno	Pin
76.45	Perno molla	Pin
80.08	Grilletto chiusura	Trigger
81.16	Grilletto comando	Trigger
90.07	Molla	Spring
91.07	Molla	Spring
91.08	Molla	Spring
92.01X	Molla	Spring
93.07	Molla	Spring
22.00.81	Battente	Driver
53.05.80	Caricatore	Magazine
62.05.81	Carrello	Slider
70.00.81	Spingipunto	Pusher
81.00.80	Controtestina	Nose
91.01.81	Testina	Nose plate
D01	Bocchetta olio	Oiler

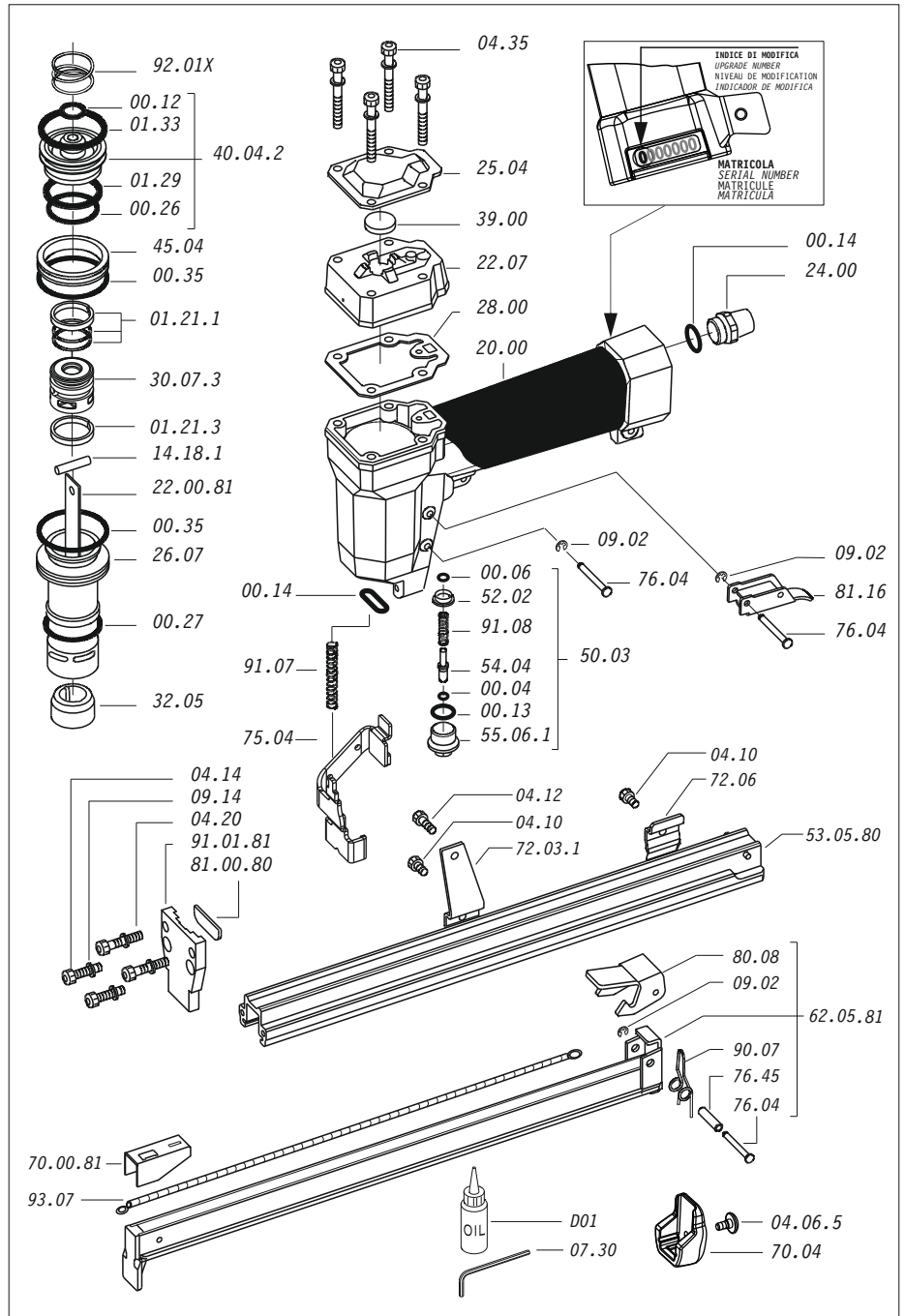

Guarnizioni - O-Rings - Dichtungen - Joints - Empaquetadura de anillo - Λαστιχακια - Kit de o-rings - O-ringen - Pakninger

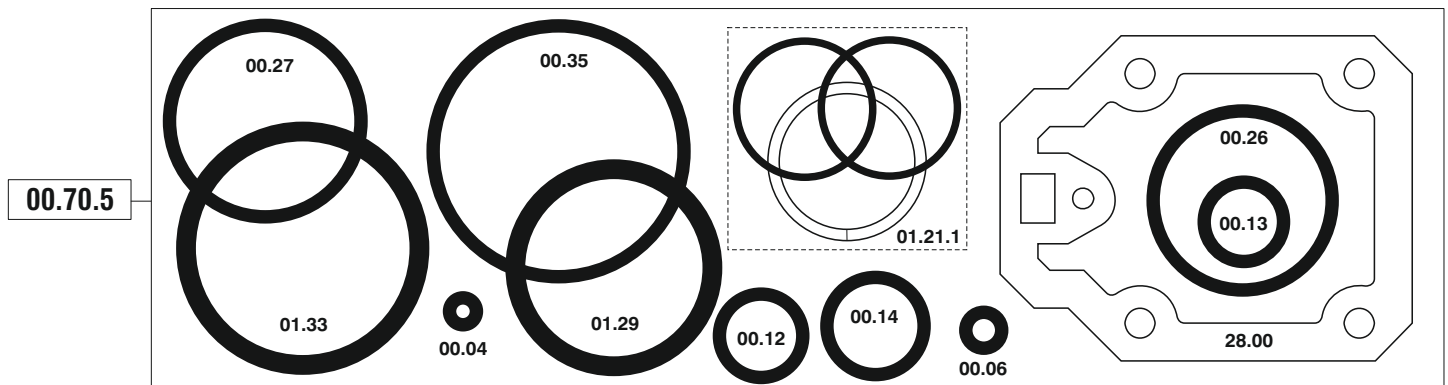

81P SCL

cod. 11461690

Indice di modifica
Upgrade number

6

6019800