

Caricamento - Loading

Caricamento da sotto Bottom load magazine

- **Premere il grilletto chiusura**
Press the magazine latch
- **Arretrare il carrello**
Pull the slider

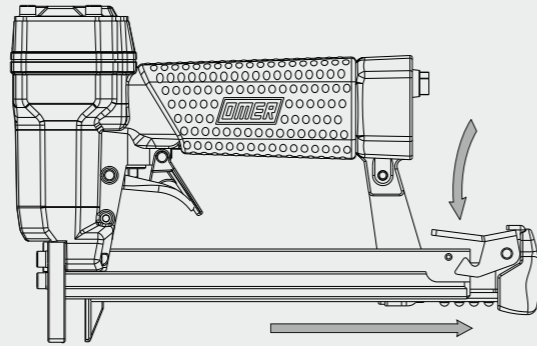

Non azionare MAI il grilletto comando durante il caricamento della graffatrice.
NEVER pull the trigger while loading magazine.

- **Capovolgere la graffatrice**
Turn the tool up side down
- **Inserire le graffe**
Load the magazine with staples
- **Chiudere il carrello**
Shut the slider

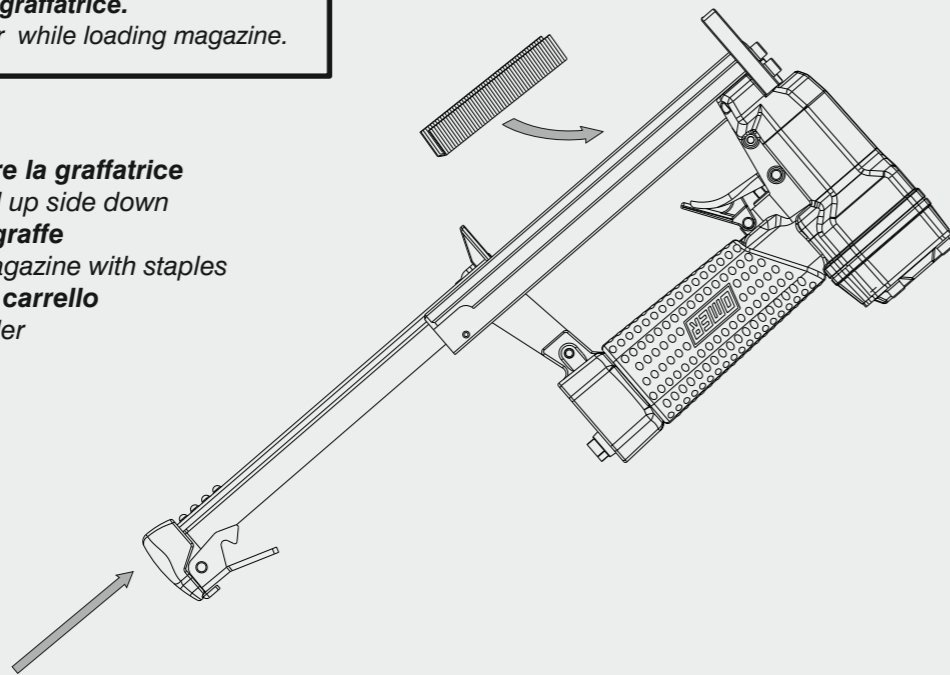

Caricamento dischi - Disk loading

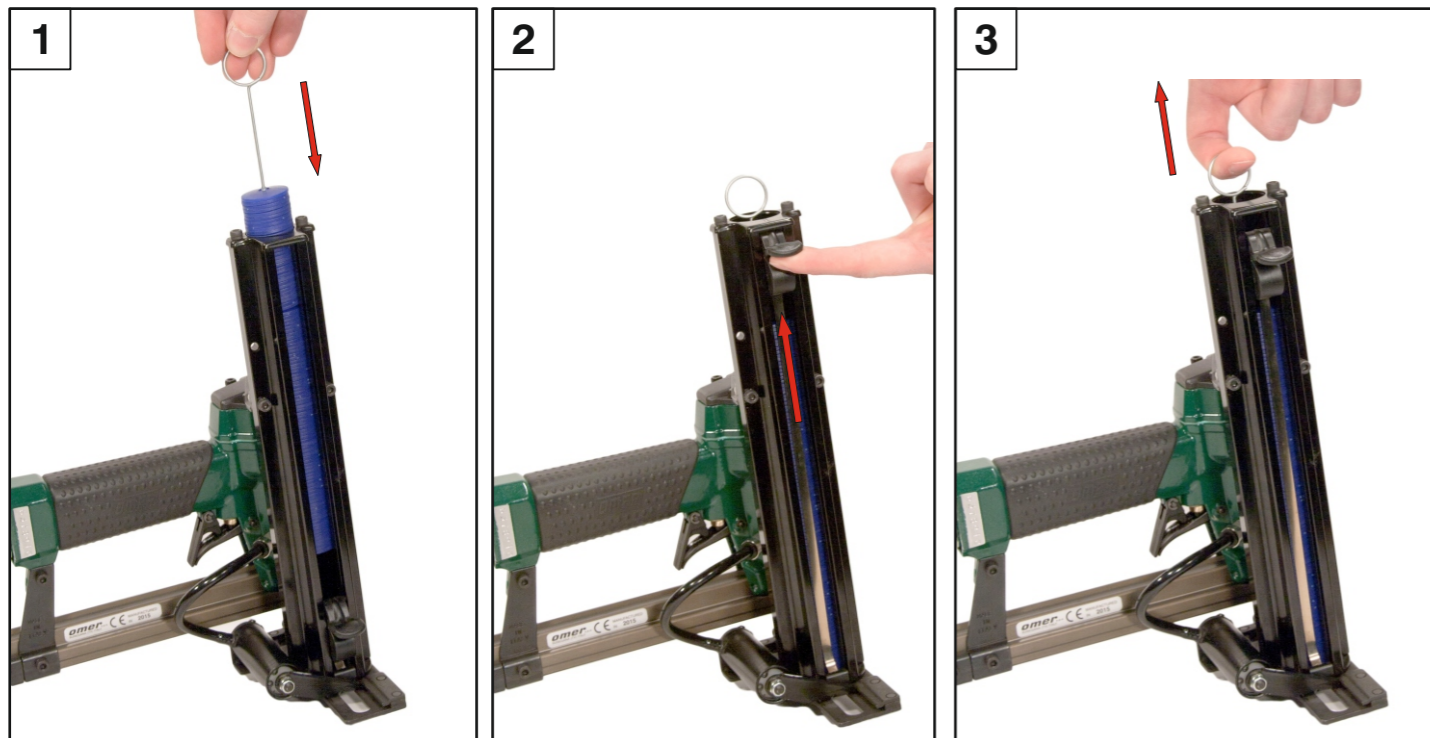

OMER

Manuale d'uso, manutenzione e parti di ricambio
Use, maintenance and spare parts manual
Gebrauchsanweisung, Instandhaltungsrichtlinien und Ersatzteile
Manuel d'utilisation, entretien et pièces de rechange
Manual de uso, mantenimiento y repuestos
Εγχειρίδιο χρήσης, συντήρησης και ανταλλακτικών
Manual de utilização, manutenção e partes sobresselentes
Handleiding voor gebruik, onderhoud en reservedelslste
Brugsanvisning, vedligeholdelse og reservedelslste

Parte 2
Part 2
Teil 2
Partie 2
Part 2
2^ο Μερὸς
Parte 2
Deel 2
Del 2



83P DK

cod. 1146390DK

1146390DK_83PDK_4 101019 IV

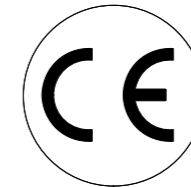

Dati tecnici Technical data Technische daten	Données techniques Datos tècnicos Τεχνικά χαρακτηριστικά	Dados tècnicos Technischegegevens Teknische data
Misure impiegabili mm Usable lengths mm Gebrauchliche Längen mm	Mesures utilisable mm Medidas que se pueden emplear mm Διαστάσεις σε μμ	Medidas que se podem utilizar mm Te gebruiken engtes in mm Brugbare laengder i mm
		10 ÷ 16
Capacità caricatore n° punti Magazine capacity No. of fasteners Magazinkapazität Nägel	Capacité chargeur n° de points Capacidad cargador n° puntos Δυνατότητα γεμιστέρα, σπινδότερες	Capacidade carregador n° pontos Capaciteit magazijn in aantal spijkers Kapacitet af magasin antal klemme
		80 (100 disk)
Pressione d'esercizio Working pressure Betriebsdruck	Pression de fonctionnement Presión de trabajo Πίεση λειτουργίας ατμ.	Pressao de trabalho Werkdruk Arbejds tryk bar
		5 ÷ 6,5 bar 70 ÷ 95 psi
Consumo aria litri/colpo Air consumption litres/shot Luftverbrauch Liter/Schlag	Consommation air litre/coup Consumo aire-litros/golpe Καταναλοση αερα λ/ξτπημα	Consumo ar litro/golpe Luchtverbruik liter/schot Luftforbrug liter/skud
		0,18
Peso kg Weight kg Gewicht kg	Poids kg Peso kg Βαρος κγ	Peso kg Gewicht in kg Vaegt kg
		1,60
Dimensioni (AxBxH) mm Dimensions mm Größe mm	Dimension mm Dimensiones mm Δυνατότητα γεμιστέρα, σπινδότερες	Dimencoes mm Afmetingen in mm Dimensioner mm
		223x128x265
EN 12549 :1999 ISO 11201 :1995		
Pressione sonora in pos. operatore Sound pressure at the workstation Lärmintensität am Arbeitsplatz	Pression acoustique près de l'opérateur Presión sonora en posición encargado Ακουστική πίεση στη θέση χειριστού	Intensidade sonora perto do operador Geluidssterkte op de werkplek Lydstyrke på operatorposten
		84,3 dB(A)
EN 12549 :1999 ISO 3744 :1994		
Potenza sonora emessa Emitted sound power Ausgestrahlte Lärmintensität	Puissance acoustique émise Potencia sonora emitida Ακουστική ισχυ	Potência sonora emitida Uitgestraalde geluidssterkte Udsendt lydstyrke
		93,7 dB(A)
EN 28662 :1992 ISO 5349 :1986 ISO 8662 -11		
Valore medio ponderato di vibrazione sull'impugnatura max.33 colpi Weighted mean value of vibration on the grip max.33 shots Mitteler Vibrationswert, am Griff gemessen max.33 Schäge	Valeur moyenne pondérée de vibration mesurée sur la poignée max.33 coups Valor medio ponderado de vibracion medida en la empuñadura max.33 golp Μεσος ορος μετρησης κραδασμον στη χειρολαβη μαξ.33 ξτπημα	Valor medio ponderado de vibracao medida no punho max.33 golpes Gewogen gemiddelde vibratiewaarde max.33 schot Middelvaerdi af vibrationer pa handtaget max.33 skud
		<2,5 m/s²

Tipo di punto
Type of fastener
Befestigungselement
Type d'agrafe
Tipo de punto
Τυπος κάρφιου
Tipo de ponto
Type nietjes
Tilspændingstype

83P

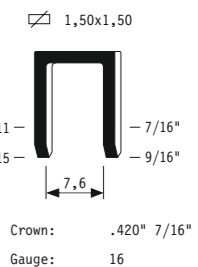

DK25

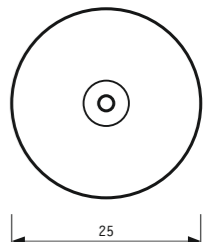

Parti di ricambio - Spare parts - Ersatzteile - Pièces de rechange - Piezas de repuesto
Ανταλλακτικά - Partes sobresselentes - Tabel te raadplegen - Reservedele

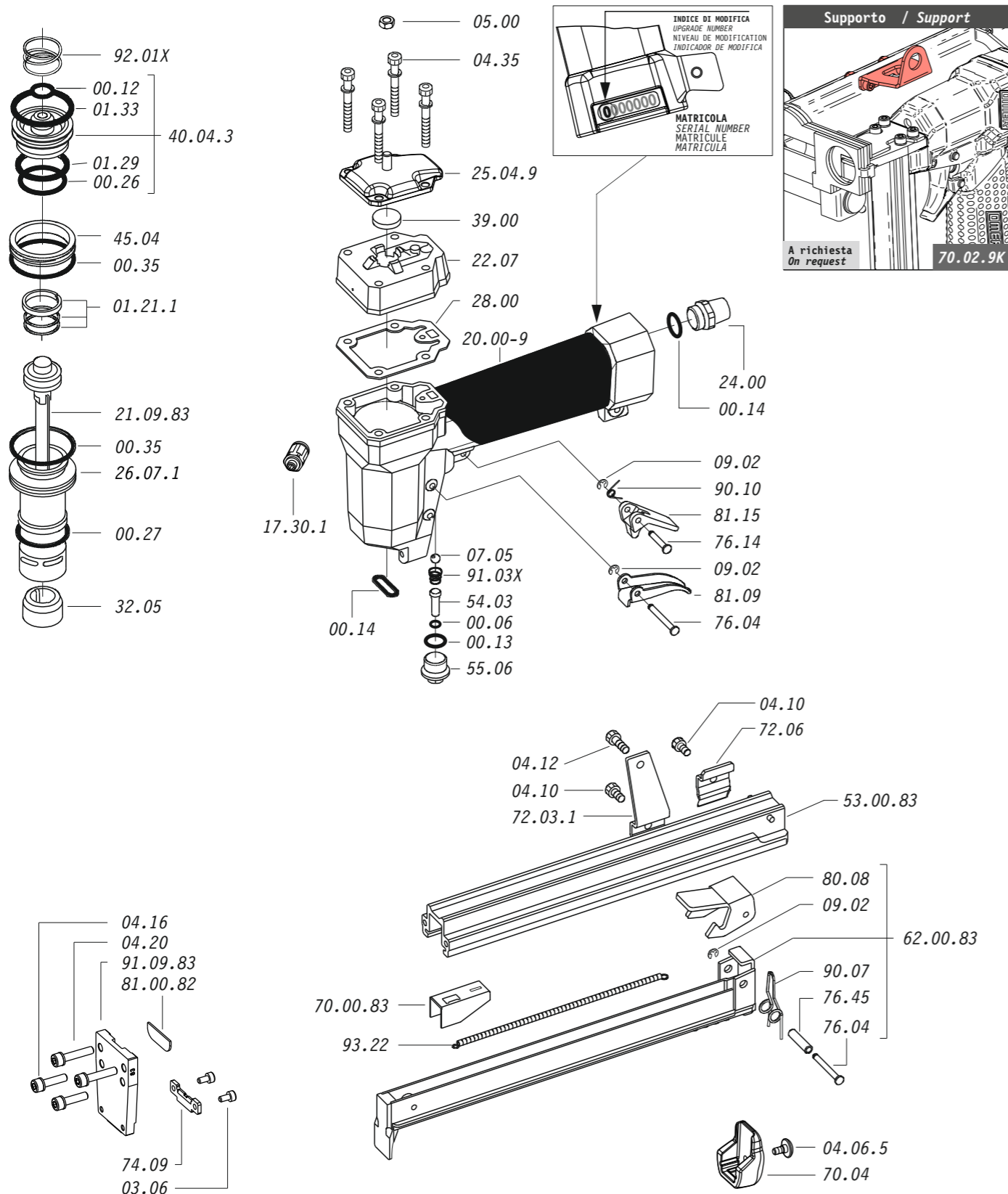

Dotazioni - Equipment - Ausrüstung - Équipements - Equipamiento - Παρεχόμενα
Equipamento - Uitrusting - Udstyr

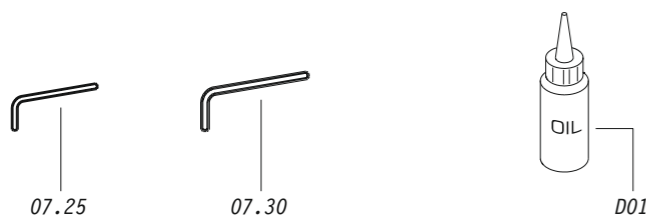

83P DK

cod. 1146390DK

Parti di ricambio - Spare parts - Ersatzteile - Pièces de rechange - Piezas de repuesto
Ανταλλακτικά - Partes sobresselentes - Tabel te raadplegen - Reservedele

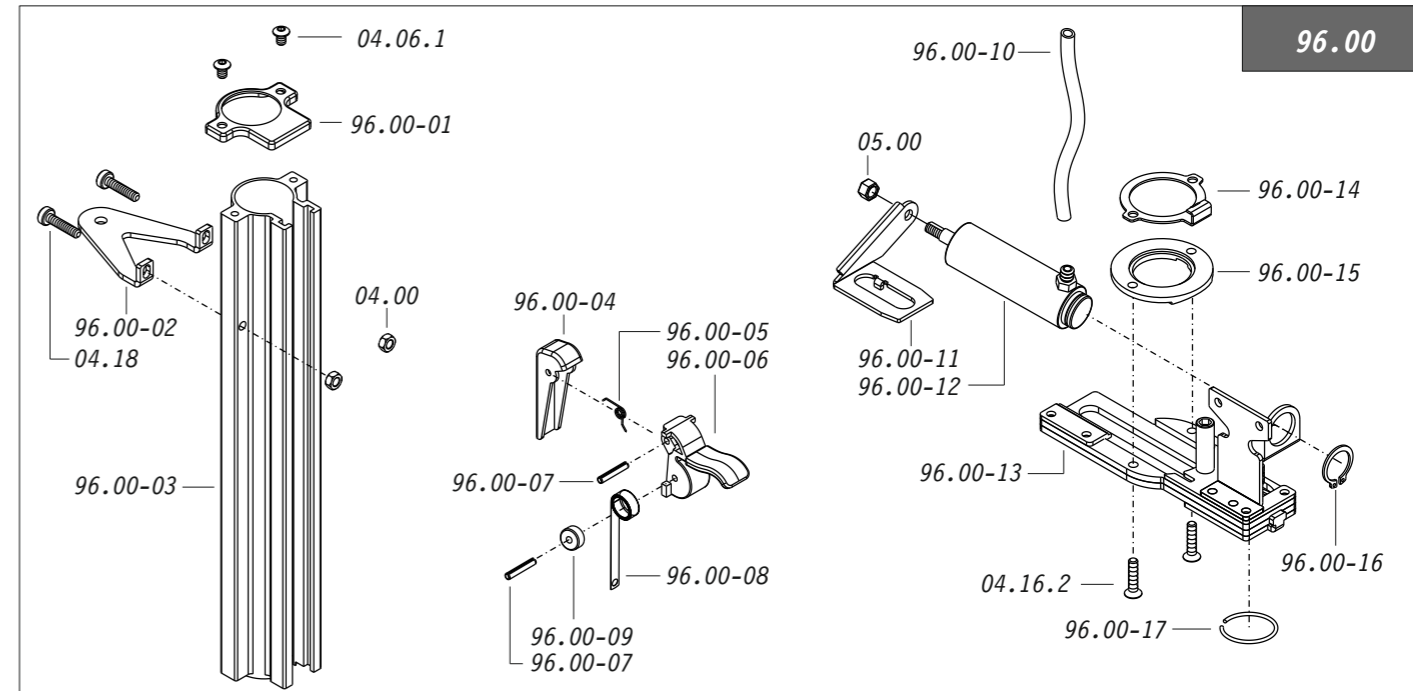

Cod.	Descrizione	Description	Cod.	Descrizione	Description	Cod.	Descrizione	Description
00.06	O-Ring	O-Ring	22.07	Testa	Head	96.00-02	Supporto	Support
00.12	O-Ring	O-Ring	24.00	Silenziatore	Silencer	96.00-03	Caricatore dischi	Disk magazine
00.13	O-Ring	O-Ring	25.04.9	Deflettore	Exhaust deflector	96.00-04	Spingidisco	Pusher
00.14	O-Ring	O-Ring	26.07.1	Cilindro	Cylinder	96.00-05	Molla	Spring
00.26	O-Ring	O-Ring	28.00	Guarnizione	Gasket	96.00-06	Leva	Latch
00.27	O-Ring	O-Ring	32.05	Ammortizzatore	Bumper	96.00-07	Perno	Pin
00.35	O-Ring	O-Ring	39.00	Guarnizione scarico	Exhaust gasket	96.00-08	Molla	Spring
01.21.1	Guarnizione	Gasket	40.04.3	Valvola completa	Valve ass'y	96.00-09	Rullo molla	Roller
01.29	O-Ring	O-Ring	45.04	Anello valvola	Ring	96.00-10	Tubo	Tube
01.33	O-Ring	O-Ring	54.03	Pulsante	Trigger valve	96.00-11	Alimentatore dischi	Disk feeder
03.06	Vite	Screw	55.06	Raccordo	Bush	96.00-12	Pistone	Piston
04.00	Dado	Nut	70.04	Protezione	Guard	96.00-13	Piastra	Plate
04.06.1	Vite	Screw	70.02.9K	Supporto bilanciante	Tool hangers supp.	96.00-14	Anello	Ring
04.06.5	Vite	Screw	72.06	Fermo carrello	Slider stop	96.00-15	Anello	Ring
04.10	Vite	Screw	72.03.1	Reggicaricatore	Support	96.00-16	Anello elastico	Elastic ring
04.12	Vite	Screw	74.09	Piastrina	Plate	96.00-17	Anello	Ring
04.14	Vite	Screw	76.04	Perno	Pin	21.09.83	Battente	Driver
04.16.2	Vite	Screw	76.14	Perno	Pin	53.00.80	Caricatore	Magazine
04.18	Vite	Screw	76.45	Perno molla	Pin	62.00.83	Carrello	Slider
04.18	Vite	Screw	80.08	Grilletto chiusura	Trigger	70.00.83	Grilletto comando	Trigger
04.18	Vite	Screw	81.09	Grilletto comando	Trigger	81.00.82	Controtestina	Nose
04.18	Vite	Screw	81.15	Controgrilletto	Safety	91.09.83	Testina	Nose plate
04.18	Vite	Screw	90.07	Molla	Spring	D01	Bocchetta olio	Oiler
04.18	Vite	Screw	90.10	Molla	Spring			
04.18	Vite	Screw	91.03X	Molla	Spring			
04.18	Vite	Screw	92.01X	Molla	Spring			
04.18	Vite	Screw	93.22	Molla	Spring			
04.18	Vite	Screw	96.00	Kit caricatore disc.	Magazine disk Kit			
04.18	Vite	Screw	96.00-01	Tappo	Cap			

Guarnizioni - O-Rings - Dichtungen - Joints - Empaquetadura de anillo - Λαστιχάκια - Kit de o-rings - O-ringen - Pakninger

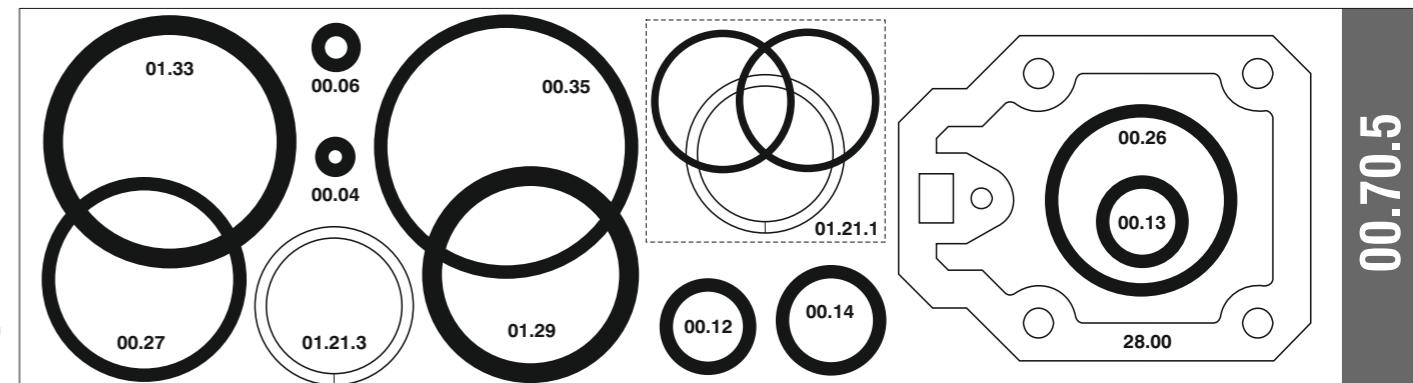

83P DK

cod. 1146390DK

Indice di modifica
Upgrade number

4

4378910

00.70.5

1146390DK_83PDK_4_101019_IV