



<b>Manuale d'uso, manutenzione e parti di ricambio</b>	<b>Parte 2</b>
<b>Use, maintenance and spare parts manual</b>	<b>Part 2</b>
<b>Gebrauchsanweisung, Instandhaltungsrichtlinien und Ersatzteile</b>	<b>Teil 2</b>
<b>Manuel d'utilisation, entretien et pièces de rechange</b>	<b>Partie 2</b>
<b>Manual de uso, mantenimiento y repuestos</b>	<b>Part 2</b>
<b>Manual de utilização, manutenção e partes sobresselentes</b>	<b>Parte 2</b>
<b>Handleiding voor gebruik, onderhoud en reservedelslste</b>	<b>Deel 2</b>
<b>Brugsanvisning, vedligeholdelse og reservedelslste</b>	<b>Del 2</b>

# 3G.16 V

cod. 1154380



1154380\_3G16V\_6 100510 IV

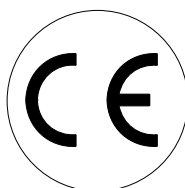

<b>Dati tecnici</b> Technical data Technische daten	<b>Données techniques</b> Datos tècnics	<b>Dados tècnics</b> Technischegegevens Teknische data	
<b>Misure impiegabili mm</b> Usable lengths mm Gebrauchliche Längen mm	Mesures utilisable mm Medidas que se pueden emplear mm	Medidas que se podem utilizar mm Te gebruiken engtes in mm Brugbare laengder i mm	<b>4 ÷ 16</b>
<b>Capacità caricatore n° punti</b> Magazine capacity No. of fasteners Magazinkapazität Nägel	Capacité chargeur n° de points Capacidad cargador n° puntos	Capacidade carregador n° pontos Capaciteit magazijn in aantal spijkers Kapacitet af magasin antal klemme	<b>185</b>
<b>Pressione d'esercizio</b> Working pressure Betriebsdruck	Pression de fonctionnement Presión de trabajo	Pressao de trabalho Werkdruk Arbejds tryk bar	<b>4 ÷ 6 bar</b> <b>60 ÷ 90 psi</b>
<b>Consumo aria litri/colpo</b> Air consumption litres/shot Luftverbrauch Liter/Schlag	Consommation air litre/coup Consumo aire-litros/golpe	Consumo ar litro/golpe Luchtverbruik liter/schot Luftforbrug liter/skud	<b>0,13</b>
<b>Peso kg</b> Weight kg Gewicht kg	Poids kg Peso kg	Peso kg Gewicht in kg Vaegt kg	<b>0,95</b>
<b>Dimensioni (AxBxH) mm</b> Dimensions mm Größe mm	Dimension mm Dimensiones mm	Dimencoes mm Afmetingen in mm Dimensioner mm	<b>216x43x148</b>
<b>EN 12549 :1999 ISO 11201 :1995</b>			
<b>Pressione sonora in pos. operatore</b> Sound pressure at the workstation Lärmintensität am Arbeitsplatz	Pression acoustique près de l'opérateur Presión sonora en posición encargado	Intensidade sonora perto do operador Geluidssterkte op de werkplek Lydstyrke på operatorposten	<b>80.8 dB(A)</b>
<b>EN 12549 :1999 ISO 3744 :1994</b>			
<b>Potenza sonora emessa</b> Emitted sound power Ausgestrahlte Lärmintensität	Puissance acoustique émise Potencia sonora emitida	Potência sonora emitida Uitgestraalde geluidssterkte Udsendt lydstyrke	<b>85.7 dB(A)</b>
<b>EN 28662 :1992 ISO 5349 :1986 ISO 8662 -11</b>			
<b>Valore medio ponderato di vibrazione sull'impugnatura max.1000 colpi</b> Weighted mean value of vibration on the grip max.1000 shots Mittlerer Vibrationswert, am Griff gemessen max.1000 Schäge	Valeur moyenne pondérée de vibration mesurée sur la poignée max.1000 coups Valor medio ponderado de vibracion medida en la empuñadura max.1000 golph	Valor medio ponderado de vibracao medida no punho max.1000 golpes Gewogen gemiddelde vibratiewaarde max.1000 schot Middelvaerdi af vibrationer pa handtaget max.1000 skud	<b>7,9 m/s<sup>2</sup></b>

**Tipo di punto**  
Type of fastener  
Befestigungselement  
Type d'agrafe  
Tipo de punto  
  
Tipo de ponto  
Type nietjes  
Tilspændingstype

**3G**

0,55x0,75

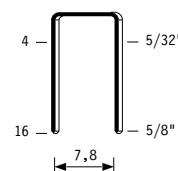

Crown: .350" (3/8")  
Thickness: .022"  
Width: .030"  
Gauge: 23

Parti di ricambio - Spare parts - Ersatzteile - Pièces de rechange - Piezas de repuesto  
 - Partes sobresselentes - Tabel te raadplegen - Reservedele

Cod.	Descrizione	Description
00.04	O-Ring	O-Ring
00.05	O-Ring	O-Ring
00.06	O-Ring	O-Ring
00.08	O-Ring	O-Ring
00.09	O-Ring	O-Ring
00.10	O-Ring	O-Ring
00.12	O-Ring	O-Ring
00.14	O-Ring	O-Ring
00.26	O-Ring	O-Ring
00.27	O-Ring	O-Ring
00.35	O-Ring	O-Ring
01.21.1	Guarnizione	Gasket
01.21.3	Guarnizione	Gasket
01.29	O-Ring	O-Ring
01.33	O-Ring	O-Ring
04.06.5	Vite	Screw
04.10	Vite	Screw
04.12	Vite	Screw
04.16	Vite	Screw
04.20	Vite	Screw
04.35	Vite	Screw
07.30	Chiave esagonale	Hex. bar wrench
09.02	Anello elastico	Elastic ring
10.04	O-Ring	O-Ring
10.09	O-Ring	O-Ring
10.16	O-Ring	O-Ring
12.10.1	Spina	Pin
14.18.1	Spina	Pin
20.03	Corpo	Body
22.07	Testa	Head
24.00	Silenziatore	Silencer
25.04.1	Deflettore	Exhaust deflector
26.07.1	Cilindro	Cylinder
28.00	Guarnizione	Gasket
30.07.3	Pistone	Piston
32.05	Ammortizzatore	Bumper
39.00	Guarnizione scarico	Exhaust gasket
39.11	Guarnizione servov.	Valve gasket
40.04.1	Valvola completa	Valve ass'y
45.04	Anello valvola	Ring
51.04.1	Cilindro servovalv.	Valve cylinder
52.01	Boccola pulsante	Tiger valve bush
53.05	Pistoncino	Piston
53.06.1	Pistone servovalvola	Valve piston
54.12	Pulsante	Trigger valve
55.07	Corpo servovalvola	Valve body
57.10	Regolatore	Regulator
57.11	Interruttore	Switch
70.04	Protezione	Guard
72.03.3	Reggicaricatore	Support
76.04	Perno	Pin
76.14	Perno	Pin
76.45	Perno molla	Pin
80.08	Grilletto chiusura	Trigger
81.09	Grilletto comando	Trigger
81.15	Controgrilletto	Trigger
90.07	Molla	Spring
90.10	Molla	Spring
91.71	Molla	Spring
92.01X	Molla	Spring
93.02	Molla	Spring
22.08.43	Battente	Driver
53.00.43	Caricatore	Magazine
62.00.43	Carrello	Slider
70.00.43	Spingipunto	Pusher
81.00.80	Controtestina	Nose
91.00.43	Testina	Nose plate
D01	Bocchetta olio	Oiler

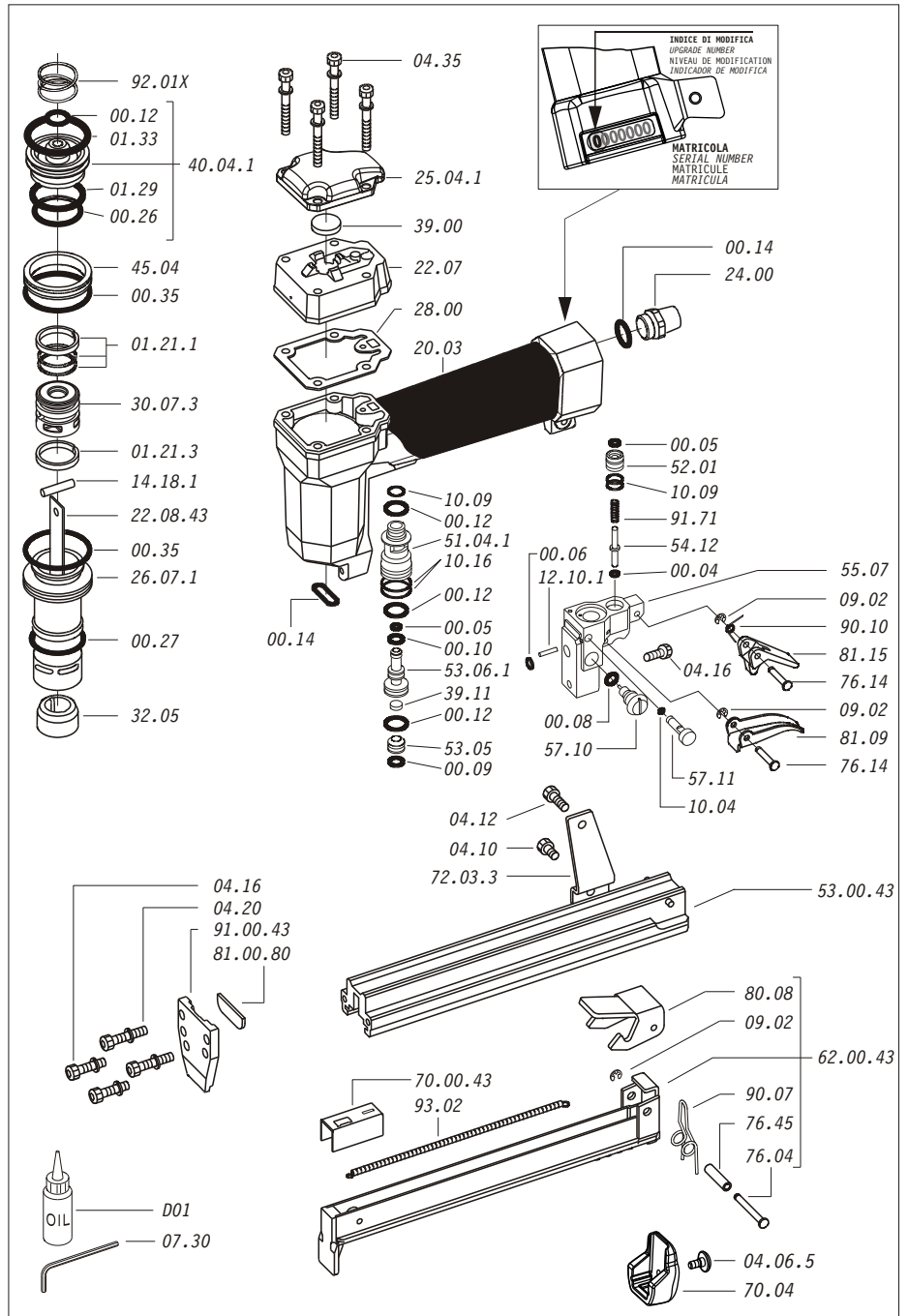

Guarnizioni - O-Rings - Dichtungen - Joints - Kit O-Ring -

- Kit O-Ring - O-ringen - Pakninger

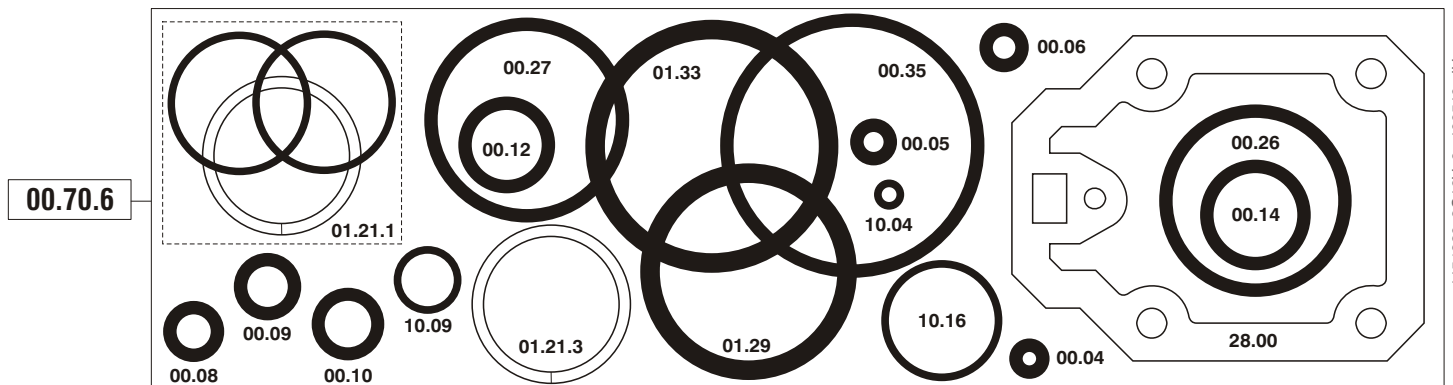

1154380\_3G16V\_6\_100510\_IV

3G.16 V

cod. 1154380

Indice di modifica  
Upgrade number

6

6019800