

Collegamento - Connection

Collegamento:
Connection:

Valvola 3/2 NC
Valve 3/2 NC

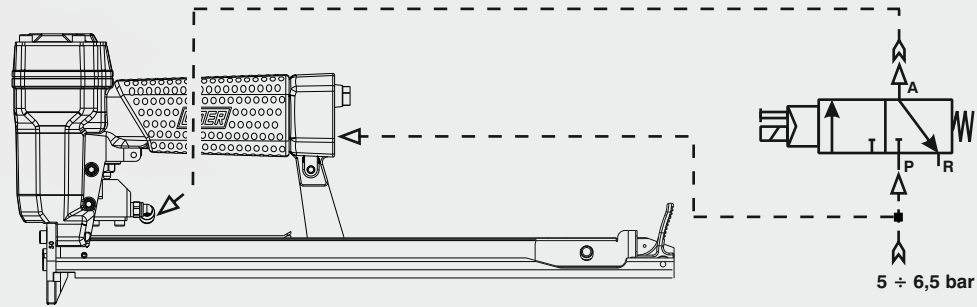

Caricamento - Loading

1 - Arretrare lo spingipunto e agganciarlo al finecorsa cio farà aprire il carter mobile
Pull the pusher backwards and lock it at the stop position at the rear of the tool, this will open the movable hold down



Non azionare MAI la valvola comando durante il caricamento o il disinceppamento della graffatrice.
NEVER actuate the command valve while loading or cleaning a jammed stapler.

2 - Inserire le graffe
Load the magazine with Staple

3 - Rilasciare lo spingipunto
Release the the pusher

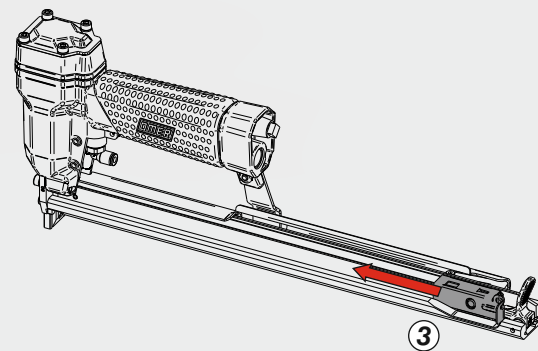
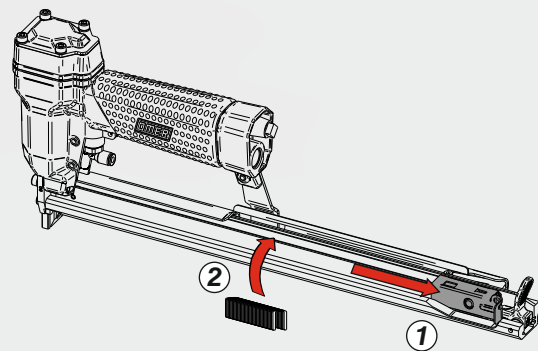

Disinceppamento macchina - Quick clearance jammed nails

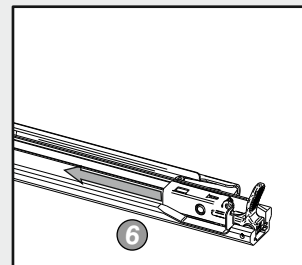
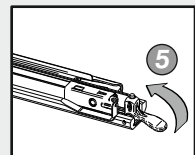
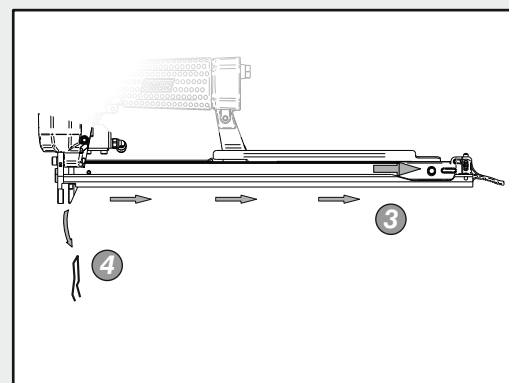
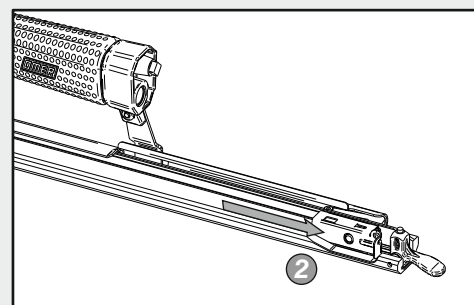
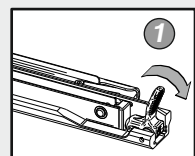

OMER

Manuale d'uso, manutenzione e parti di ricambio
Use, maintenance and spare parts manual
Gebrauchsanweisung, Instandhaltungsrichtlinien und Ersatzteile
Manuel d'utilisation, entretien et pièces de rechange
Manual de uso, mantenimiento y repuestos
Εγχειρίδιο χρήσης, συντήρησης και ανταλλακτικών
Manual de utilização, manutenção e partes sobresselentes
Handleiding voor gebruik, onderhoud en wisselstukken
Brugsanvisning, vedligeholdelse og reservedelsliste

Parte 2
Part 2
Teil 2
Partie 2
Part 2
2º Μερὸς
Parte 2
Deel 2
Del 2

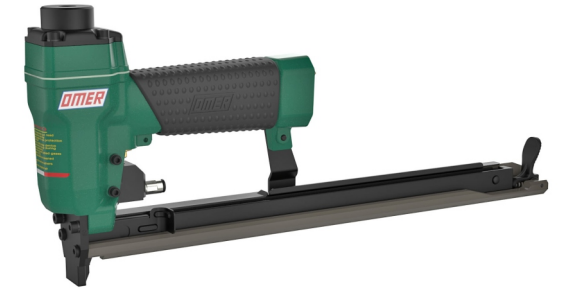

80.16 CLT-41

cod. 11560540-41

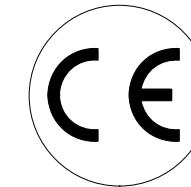

11560540-41_8016CLT-41_5 091117 IV

Dati tecnici Technical data Technische daten	Données techniques Datos tècnicos Τεχνικά χαρακτηριστικά	Dados tècnicos Technischegegevens Teknische data
--	--	--

Misure impiegabili mm Usable lengths mm Gebrauchliche Längen mm	Mesures utilisable mm Medidas que se pueden emplear mm Διαστάσεις σε μμ	Medidas que se podem utilizar mm Te gebruiken engtes in mm Brugbare laengder i mm	4 ÷ 16
Capacità caricatore n° punti Magazine capacity No. of fasteners Magazinkapazität Nägel	Capacité chargeur n° de points Capacidad cargador n° puntos Δυνατότητα γεμιστερα, σπινδτερες	Capacitade carregador n° pontos Capaciteit magazijn in aantal spijkers Kapacitet af magasin antal klemme	285
Pressione d'esercizio Working pressure Betriebsdruck	Pression de fonctionnement Presión de trabajo Πίεση λειτουργίας ατμ.	Pressao de trabalho Werkdruk Arbejds tryk bar	4 ÷ 6 bar 60 ÷ 90 psi
Consumo aria litri/colpo Air consumption litres/shot Luftverbrauch Liter/Schlag	Consommation air litre/coup Consumo aire-litros/golpe Καταναλοση αερα λ/ξτπημα	Consumo ar litro/golpe Luchtverbruik liter/schot Luftforbrug liter/skud	0,13

Peso kg Weight kg Gewicht kg	Poids kg Peso kg Βαρος κγ	Peso kg Gewicht in kg Vægt kg	1,30
---	---------------------------------	-------------------------------------	-------------

Dimensioni (AxBxH) mm Dimensions mm Größe mm	Dimension mm Dimensiones mm Δυνατότητα γεμιστερα, σπινδτερες	Dimencoes mm Afmetingen in mm Dimensioner mm	378x43x162
---	--	--	-------------------

EN 12549 :1999 ISO 11201 :1995 Pressione sonora in pos. operatore Sound pressure at the workstation Lärmintensität am Arbeitsplatz	Pression acoustique près de l'opérateur Presión sonora en posición encargado Ακουστική πίεση στη θέση χειριστου	Intensidade sonora perto do operador Geluidssterkte op de werkplek Lydstyrke på operatorposten	84,3 dB(A)
---	---	--	-------------------

EN 12549 :1999 ISO 3744 :1994 Potenza sonora emessa Emitted sound power Ausgestrahlte Lärmintensität	Puissance acoustique émise Potencia sonora emitida Ακουστική ισχυ	Potência sonora emitida Uitgestraalde geluidssterkte Udsendt lydstryrke	93,7 dB(A)
---	---	---	-------------------

EN 28662 :1992 ISO 5349 :1986 ISO 8662 -11 Valore medio ponderato di vibrazione sull'impugnatura max.33 colpi Weighted mean value of vibration on the grip max.33 shots Mitteler Vibrationswert, am Griff gemessen max.33 Schäge	Valeur moyenne pondérée de vibration mesurée sur la poignée max.33 coups Valor medio ponderado de vibracion medida en la empuñadura max.33 golp Μεσος ορος μετρησις κραδασιμον στη χειρολαβη μαξ.33 ξτπημα	Valor medio ponderado de vibracao medida no punho max.33 golpes Gewogen gemiddelde vibratiewaarde max.33 schot Middelvaerdi af vibrationer pa handtaget max.33 skud	<2,5 m/s²
---	--	---	--------------------------------

Tipo di punto
Type of fastener
Befestigungselement
Type d'agrafe
Tipo de punto
Τυπος κάρφιου
Tipo de ponto
Type nietjes
Tilspændingstype

80

0,65x0,95

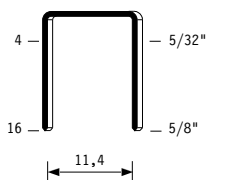

Crown: .500" (1/2")
Thickness: .025"
Width: .037"
Gauge: 21

Parti di ricambio - Spare parts - Ersatzteile - Pièces de rechange - Piezas de repuesto
Ανταλλακτικά - Partes sobresselentes - Wisselstukken - Reservedele

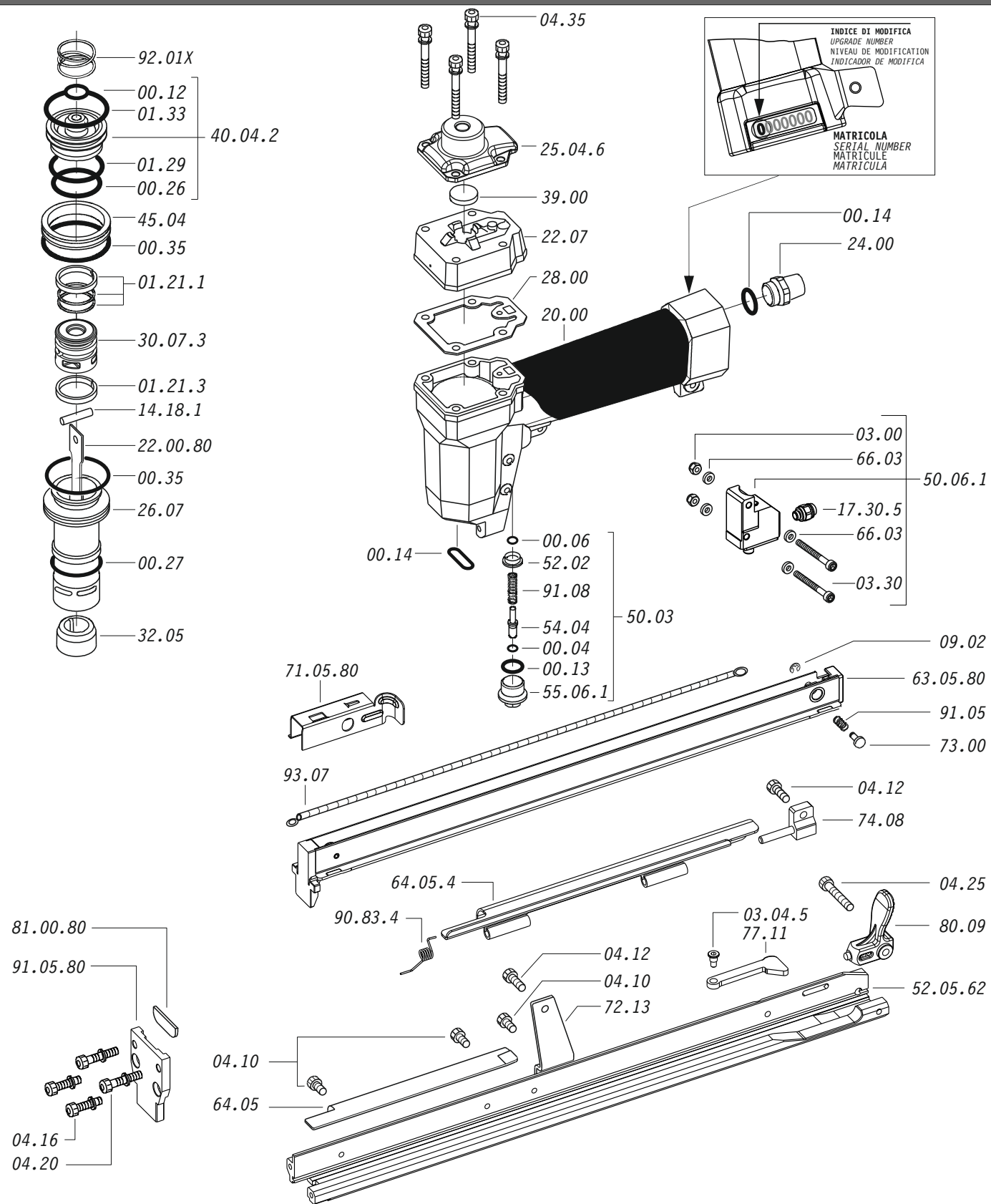

Dotazioni - Equipment - Ausrüstung - Équipements - Equipamiento - Παρεχόμενα
Equipamento - Uitrusting - Udstyr



80.16 CLT-41

cod. 11560540-41

Parti di ricambio - Spare parts - Ersatzteile - Pièces de rechange - Piezas de repuesto
Ανταλλακτικά - Partes sobresselentes - Wisselstukken - Reservedele

Cod.	Descrizione	Description
00.04	O-Ring	O-Ring
00.06	O-Ring	O-Ring
00.12	O-Ring	O-Ring
00.13	O-Ring	O-Ring
00.14	O-Ring	O-Ring
00.26	O-Ring	O-Ring
00.27	O-Ring	O-Ring
00.35	O-Ring	O-Ring
01.21.1	Guarnizione	Gasket
01.21.3	Guarnizione	Gasket
01.29	O-Ring	O-Ring
01.33	O-Ring	O-Ring
03.00	Dado	Nut
03.04.5	Vite	Screw
03.30	Vite	Screw
04.10	Vite	Screw
04.12	Vite	Screw
04.16	Vite	Screw
04.20	Vite	Screw
04.25	Vite	Screw
04.35	Vite	Screw
07.30	Chiave esagonale	Hex. bar wrench
09.02	Anello elastico	Elastic ring
14.18.1	Spina	Pin
17.30.5	Attacco	Connection
20.00	Corpo	Body
22.07	Testa	Head
24.00	Silenziatore	Silencer
25.04.6	Deflettore	Exhaust deflector
26.07	Cilindro	Cylinder
28.00	Guarnizione	Gasket
30.07.3	Pistone	Piston
32.05	Ammortizzatore	Bumper
39.00	Guarnizione scarico	Exhaust gasket
40.04.2	Valvola completa	Valve ass'y
45.04	Anello valvola	Ring
50.03	Pulsante completo	Trigger valve ass'y
50.06.1	Comando a distanza	Remote control trigger
52.02	Boccola	Bush
54.04	Pulsante	Trigger valve
55.06.1	Raccordo	Bush
64.05	Carter	Hold down
64.05.4	Carter mobile	Hold down
66.03	Rondella	Washer
77.11	Leva	Lever
72.13	Reggicaricatore	Support
73.00	Perno	Pin
74.08	Staffa	Support
80.09	Grilletto chiusura	Trigger
91.05	Molla	Spring
91.08	Molla	Spring
90.83.4	Molla	Spring
92.01X	Molla	Spring
93.07	Molla	Spring
22.00.80	Battente	Driver
52.05.62	Caricatore	Magazine
63.05.80	Carrello	Slider
71.05.80	Spingipunto	Pusher
81.00.80	Controtestina	Nose
91.05.80	Testina	Nose plate
D01	Bocchetta olio	Oiler

Guarnizioni - O-Rings - Dichtungen - Kits O-rings - Λοστίγια - Kit O-rings - Pakninger

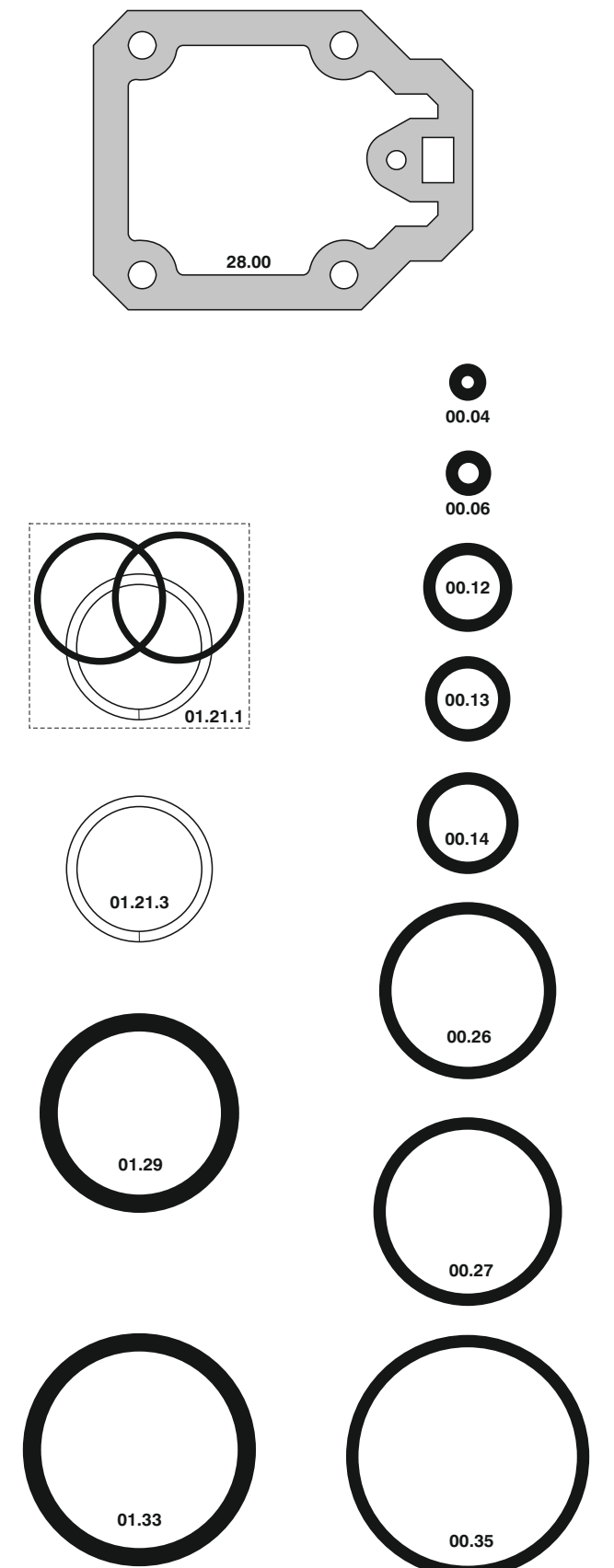

00.70.5

11560540-41_8016CLT-41_5_091117 IV

80.16 CLT-41

cod. 11560540-41

Indice di modifica
Upgrade number

5

6455732