

## Caricamento - Loading

### Caricamento da sotto Bottom load magazine

- Capovolgere la graffatrice  
Turn the tool up side down
- Inserire le graffe  
Load the magazine with staples
- Chiudere il carrello  
Shut the slider

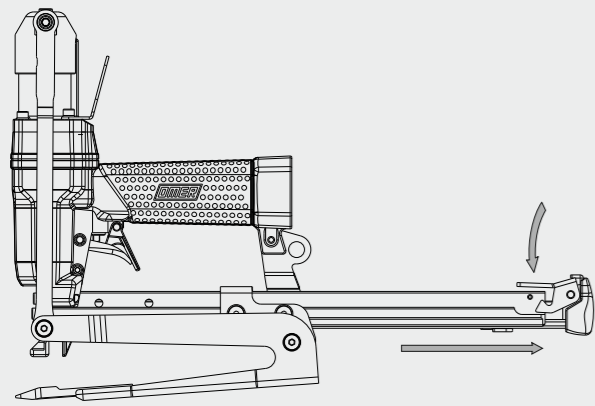

- Premere il grilletto chiusura  
Press the magazine latch
- Arretrare il carrello  
Pull the slider

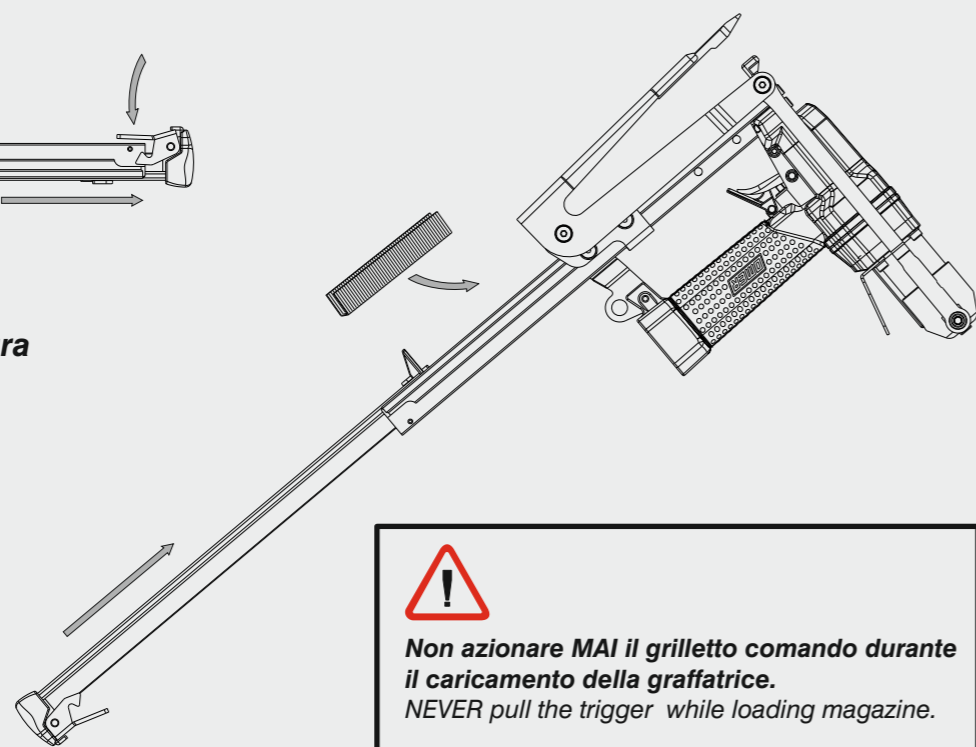

**!**  
**Non azionare MAI il grilletto comando durante il caricamento della graffatrice.**  
**NEVER pull the trigger while loading magazine.**



<b>Manuale d'uso, manutenzione e parti di ricambio</b>	<b>Parte 2</b>
<b>Use, maintenance and spare parts manual</b>	<b>Part 2</b>
<b>Gebrauchsanweisung, Instandhaltungsrichtlinien und Ersatzteile</b>	<b>Teil 2</b>
<b>Manuel d'utilisation, entretien et pièces de rechange</b>	<b>Partie 2</b>
<b>Manual de uso, mantenimiento y repuestos</b>	<b>Part 2</b>
<b>Εγχειρίδιο χρήσης, συντήρησης και ανταλλακτικών</b>	<b>2° Μέρος</b>
<b>Manual de utilização, manutenção e partes sobresselentes</b>	<b>Parte 2</b>
<b>Handleiding voor gebruik, onderhoud en reservedeelslste</b>	<b>Deel 2</b>
<b>Brugsanvisning, vedligeholdelse og reservedeelslste</b>	<b>Del 2</b>



# PL50.16 LJ

cod. 11567530

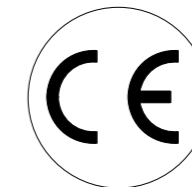

11567530\_PL5016LJ\_5 200317 IV

Dati tecnici Technical data Technische daten	Données techniques Datos técnicos Τεχνικά χαρακτηριστικά	Dados técnicos Technische gegevens Teknische data
<b>Misure impieghiabili mm</b> Usable lengths mm Gebrauchliche Längen mm	Mesures utilisables mm Medidas que se pueden emplear mm Διαστάσεις σε mm	Medidas que se podem utilizar mm Te gebruiken lengtes in mm Brugbare laengder i mm
<b>Capacità caricatore n° punti</b> Magazine capacity No. of fasteners Magazinkapazität Nägel	Capacité chargeur n° de points Capacidad cargador n° puntos Δυνατότητα γεμιστέρα, σπινδτερες	Capacidade carregador n° pontos Capaciteit magazijn in aantal spijkers Kapacitet af magasin antal klemme
<b>Pressione d'esercizio</b> Working pressure Betriebsdruck	Pression de fonctionnement Presión de trabajo Πίεση λειτουργίας ατμ.	Pressão de trabalho Werkdruk Arbejds tryk bar
<b>Consumo aria litri/colpo</b> Air consumption litres/shot Luftverbrauch Liter/Schlag	Consommation air litre/coup Consumo aire-litros/golpe Κατανάλωση αέρα λ/ξτππημα	Consumo ar litro/golpe Luchtverbruik liter/schot Luftforbrug liter/skud
<b>Peso kg</b> Weight kg Gewicht kg	Poids kg Peso kg Βαρος κγ	Peso kg Gewicht in kg Vaegt kg
<b>Dimensioni (AxBxH) mm</b> Dimensions mm Größe mm	Dimension mm Dimensiones mm Δυνατότητα γεμιστέρα, σπινδτερες	Dimencoes mm Afmetingen in mm Dimensioner mm

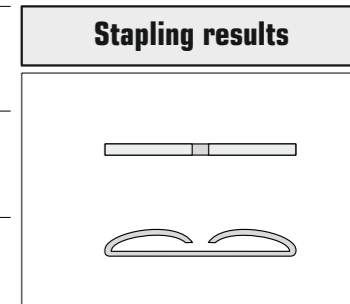

## Caratteristiche - Features

### Spessore Thickness

### Dimensioni Ganascia Jaw Dimension

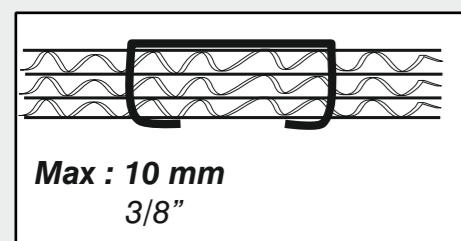
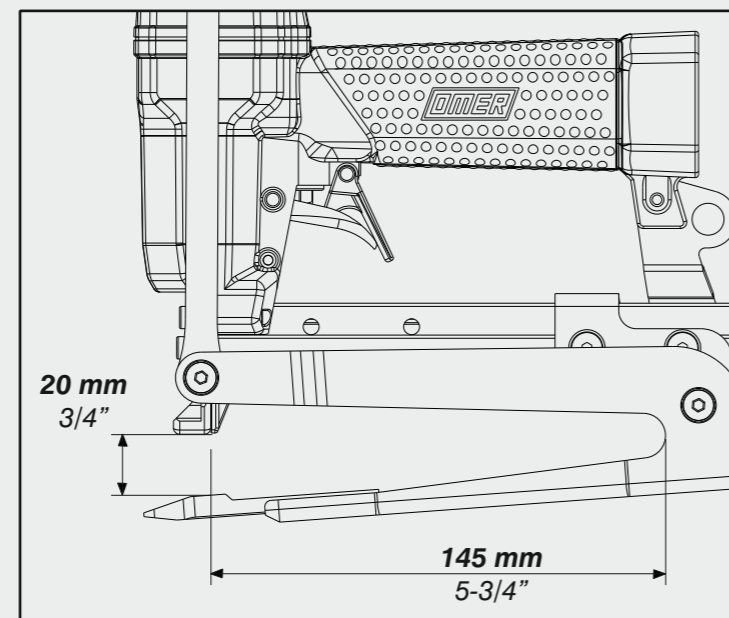
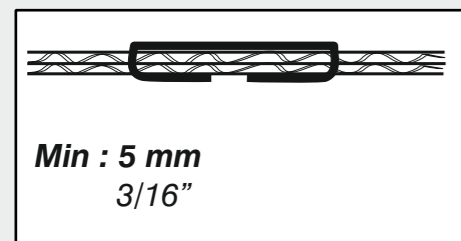

**Tipo di punto**  
Type of fastener  
Befestigungselement  
Type d'agrafe  
Tipo de punto  
Τυπος κάρφιου  
Tipo de ponto  
Type nietjes  
Tilspændingstype

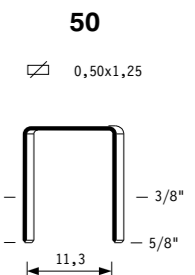

Gauge: 20  
Crown: .484" (1/2")

<b>EN 12549 :1999 ISO 11201 :1995</b>	<b>Pressione sonora in pos. operatore</b> Sound pressure at the workstation Lärmintensität am Arbeitsplatz	Pression acoustique près de l'opérateur Presión sonora en posición encargado Ακουστική πίεση στη θέση χειριστού	Intensidade sonora perto do operador Geluidssterkte op de werkplek Lydstyrke på operatorposten
<b>EN 12549 :1999 ISO 3744 :1994</b>	<b>Potenza sonora emessa</b> Emitted sound power Ausgestrahlte Lärmintensität	Puissance acoustique émise Potencia sonora emitida Ακουστική ισχύς	Potência sonora emitida Uitgestraalde geluidssterkte Udsendt lydstyrke
<b>EN 28662 :1992 ISO 5349 :1986 ISO 8662 -11</b>	<b>Valore medio ponderato di vibrazione sull'impugnatura max.33 colpi</b> Weighted mean value of vibration on the grip max.33 shots Mittlerer Vibrationswert, am Griff gemessen max.33 Schläge	Valeur moyenne pondérée de vibration mesurée sur la poignée max.33 coups Valor medio ponderado de vibracion medida en la empuñadura max.33 golp Μεσος ορος μετρησης κραδασιμου στη χειρολαβη max.33 ξτππημα	Valor medio ponderado de vibracao medida no punho max.33 golpes Gewogen gemiddelde vibratiewaarde max.33 schot Middelvaerdi af vibrationer pa handtaget max.33 skud

Parti di ricambio - Spare parts - Ersatzteile - Pièces de rechange - Piezas de repuesto  
Ανταλλακτικά - Partes sobresselentes - Tabel te raadplegen - Reservedele

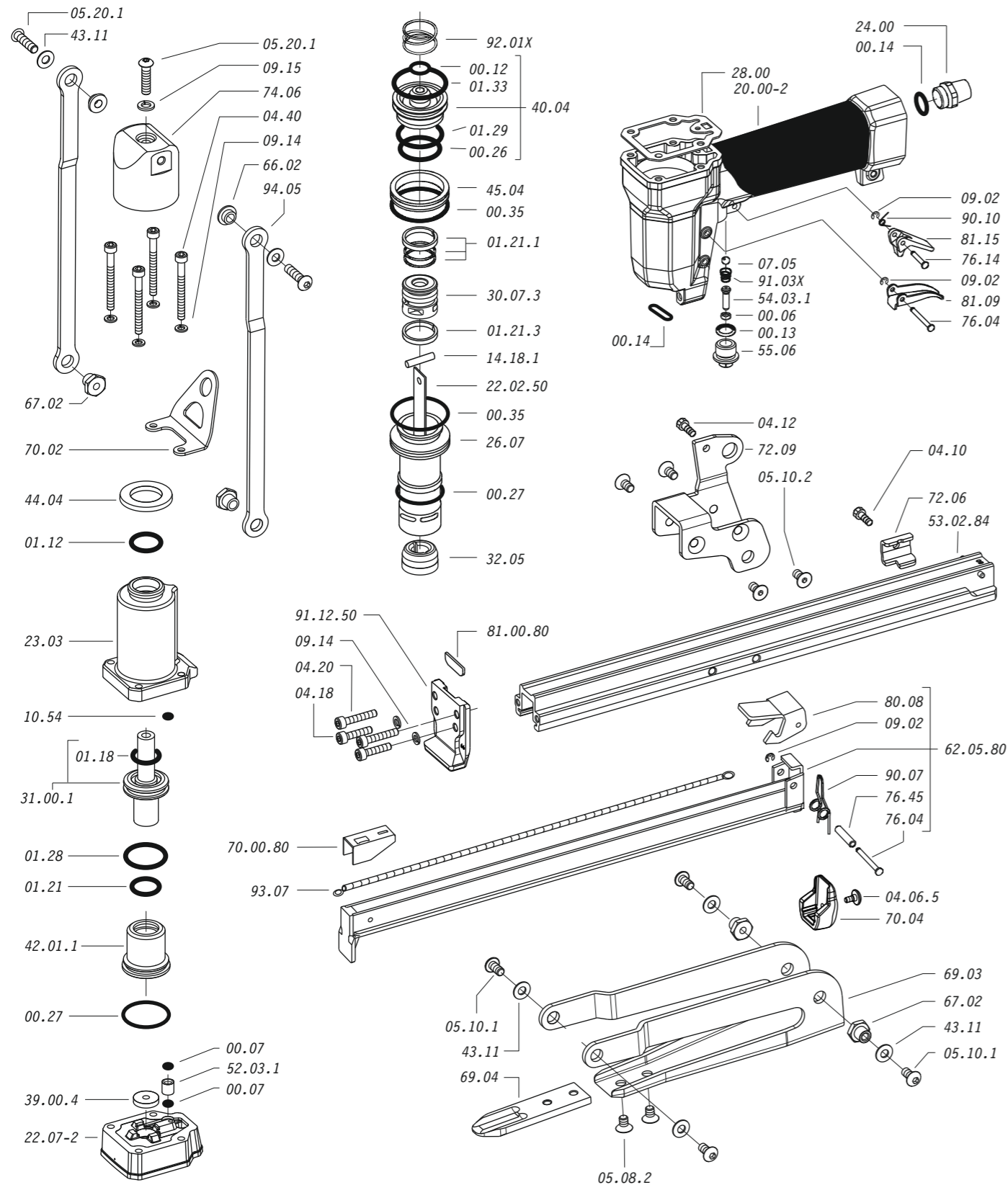

Dotazioni - Equipment - Ausrüstung - Équipements - Equipamiento - Παρεχόμενα  
Equipamento - Uitrusting - Udstyr

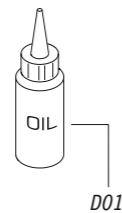

**PL50.16 LJ**

cod. 11567530

Parti di ricambio - Spare parts - Ersatzteile - Pièces de rechange - Piezas de repuesto  
Ανταλλακτικά - Partes sobresselentes - Tabel te raadplegen - Reservedele

Cod.	Descrizione	Description
00.06	O-Ring	O-Ring
00.07	O-Ring	O-Ring
00.12	O-Ring	O-Ring
00.13	O-Ring	O-Ring
00.14	O-Ring	O-Ring
00.26	O-Ring	O-Ring
00.27	O-Ring	O-Ring
00.35	O-Ring	O-Ring
01.12	O-Ring	O-Ring
01.18	O-Ring	O-Ring
01.21	O-Ring	O-Ring
01.21.1	Guarnizione	Gasket
01.21.3	Guarnizione	Gasket
01.28	O-Ring	O-Ring
01.29	O-Ring	O-Ring
01.33	O-Ring	O-Ring
04.06.5	Vite	Screw
04.10	Vite	Screw
04.12	Vite	Screw
04.18	Vite	Screw
04.20	Vite	Screw
04.40	Vite	Screw
05.08.2	Vite	Screw
05.10.1	Vite	Screw
05.10.2	Vite	Screw
05.20.1	Vite	Screw
07.05	Sfera	Ball
07.30	Chiave esagonale	Hex. bar wrench
09.02	Anello elastico	Elastic ring
09.14	Rondella	Washer
09.15	Rondella	Washer
10.54	O-Ring	O-Ring
14.18.1	Spina	Pin
20.00-2	Corpo	Body
22.07-2	Testa	Head
23.03	Testa superiore	Head
24.00	Silenziatore	Silencer
26.07	Cilindro	Cylinder
28.00	Guarnizione	Gasket
30.07.3	Pistone	Piston
31.00.1	Pistone ganascia	Jaws Piston
32.05	Ammortizzatore	Bumper
39.00.4	Guarnizione scarico	Exhaust gasket
40.04	Valvola completa	Valve ass'y
42.01.1	Anello superiore	Upper ring
43.11	Rondella	Washer
44.04	Ammortizzatore	Bumper
45.04	Anello valvola	Ring
52.03.1	Distanziale	Pacer
54.03.1	Pulsante	Trigger valve
55.06	Raccordo	Bush
66.02	Boccola	Bush
67.02	Boccola	Bush
69.03	Ganascia	Jaws
69.04	Ribattitore	Riveter
70.02	Supporto	Support
70.04	Protezione	Guard
72.06	Fermo carrello	Slider-Stop
72.09	Reggicaricatore	Support
74.06	Staffa	Bracket
76.04	Perno	Pin
76.14	Perno	Pin
76.45	Perno molla	Pin
80.08	Grilletto chiuso	Trigger
81.09	Grilletto comando	Trigger
81.15	Controgrilletto	Safety
90.07	Molla	Spring
90.10	Molla	Spring
91.03X	Molla	Spring
92.01X	Molla	Spring
93.07	Molla	Spring
94.05	Tirante	Connecting rod
22.02.50	Battente	Driver
53.02.84	Caricatore	Magazine
62.05.80	Carrello	Slider
70.00.80	Spingipunto	Pusher
81.00.80	Controtestina	Nose
91.12.50	Testina	Nose plate
D01	Bocchetta olio	Oiler

Guarnizioni - O-Rings - Dichtungen - Joints - Kit O-Rings - Αισθητήρας - Kit O-Rings - O-ringen - Pakninger

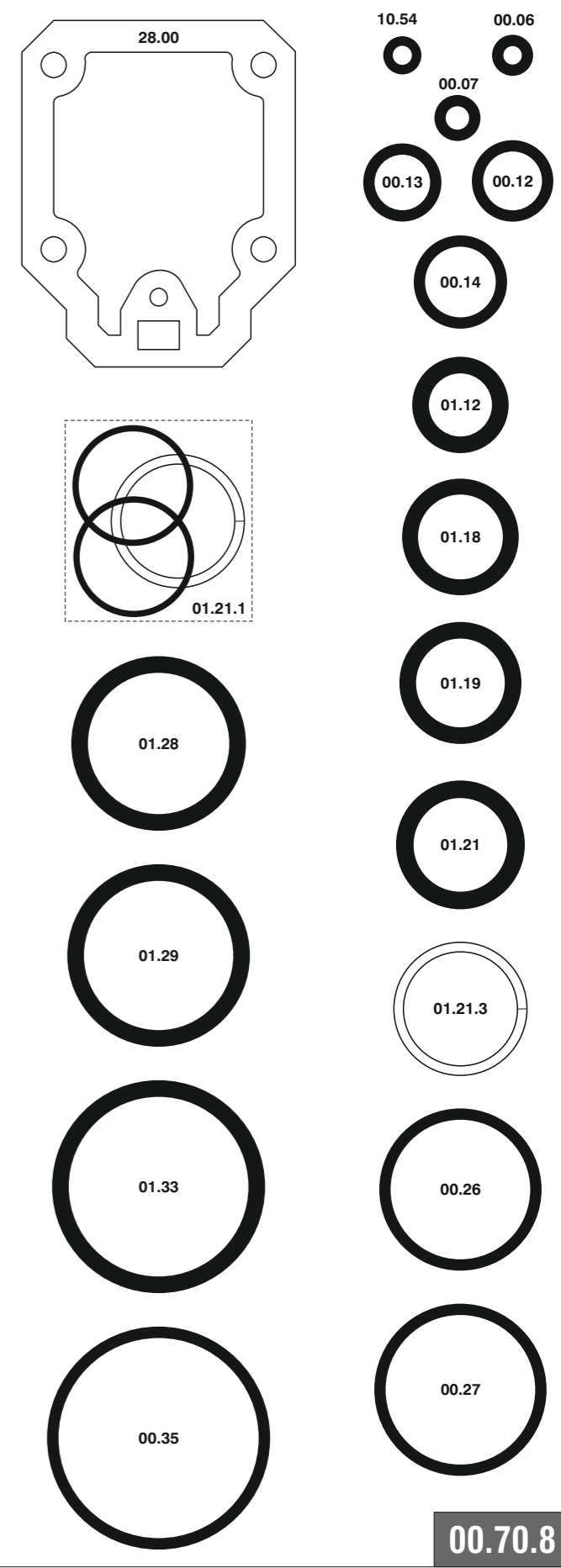

11567530\_PL5016LJ\_5\_200317\_IV

**PL50.16 LJ**

cod. 11567530

Indice di modifica  
Upgrade number

**5**