

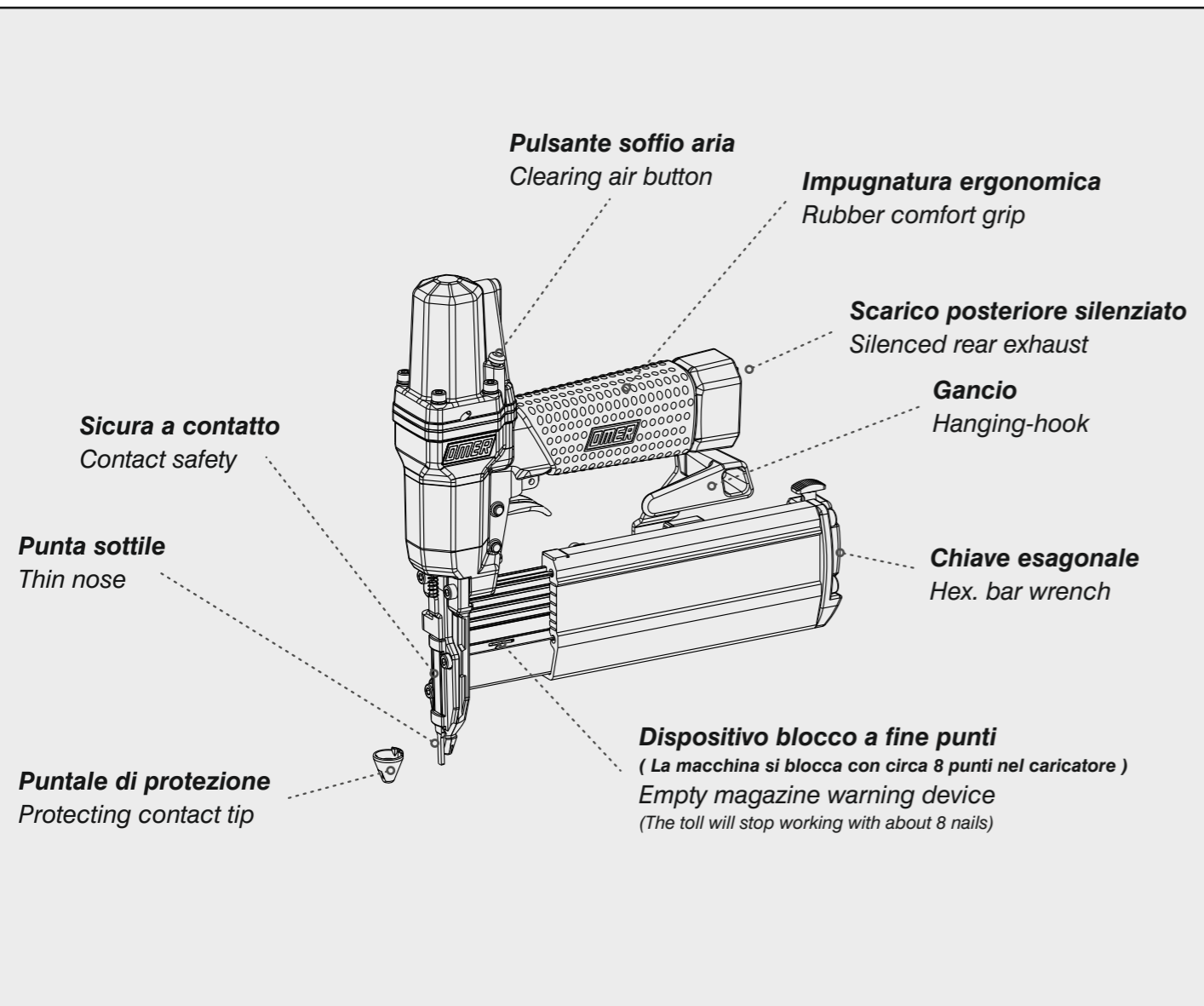

B6.50 N

cod. 1140250N



Manuale d'uso, manutenzione e parti di ricambio	Parte 2
Manual for use, maintenance and spare parts	Part 2
Bedienungs- und Wartungshandbuch sowie Ersatzteilliste	Teil 2
Mode d'emploi, de maintenance et pièces de rechange	Partie 2
Manual de uso, mantenimiento y recambios	Part 2
Εγχειρίδιο χρήσης, συντήρησης και ανταλλακτικών	Μέρος 2
Manual de uso, manutenção e peças sobresselentes	Parte 2
Handleiding voor gebruik, onderhoud en wisselstukken	Deel 2
Kullanım, bakım ve yedek parça kılavuzu	Kısım 2
Användar-, underhålls- och reservdelshandbok	Del 2

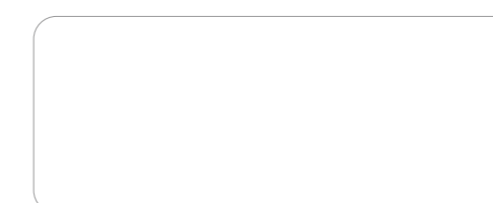

Dati tecnici Technical data Technische Daten Tekniska data	Caractéristiques techniques Datos técnicos Τεχνικά χαρακτηριστικά	Dados técnicos Technische gegevens Teknik veriler
--	---	---

Misure impiegabili Lengths Verwendbare Nagellänge Dimensioner som kan användas	Dimensions utiles Medidas de longitud Μήκος Αναλωσίμου	Medidas utilizáveis Toepasbare afmetingen Boy	22 ÷ 50
Capacità caricatore n° punti Magazine capacity Magazinkapazität: Nägel Magasinkapacitet: Antal punkter	Capacité chargeur n° de points Capacidad cargador n° puntos Δυνατότητα γεμιστέρα	Capacidade carregador n° pontos Capaciteit magazijn in aantal spijkers Dergi kapasitesi	150
Pressione d'esercizio Operating pressure Betriebsdruck Drifttryck	Pression d'exercice Presión de servicio Πίεση λειτουργίας	Pressão de serviço Werkdruk Çalışma basıncı	5 ÷ 6,5 bar 70 ÷ 95 psi
Consumo aria Air consumption Luftverbrauch Luftförbrukning	Consommation d'air Consumo aire Κατανάλωση αέρα	Consumo ar Luchtverbruik Hava tüketimi	0,22
Peso Weight Gewicht Vikt	Poids Peso Βάρος	Peso Gewicht Ağırlık	1,15
Dimensioni Dimensions Abmessungen Dimensioner (AxBxH)	Dimensions Διαστάσεις	Dimensões Afmetingen Boyutlar	192x43x254 (LxWxH)

Consumo aria Air consumption Luftverbrauch Luftförbrukning	Consommation d'air Consumo aire Κατανάλωση αέρα	Consumo ar Luchtverbruik Hava tüketimi	0,22
Peso Weight Gewicht Vikt	Poids Peso Βάρος	Peso Gewicht Ağırlık	1,15
Dimensioni Dimensions Abmessungen Dimensioner (AxBxH)	Dimensions Διαστάσεις	Dimensões Afmetingen Boyutlar	192x43x254 (LxWxH)

EN 12549 :2009 EN ISO 4871 :2009	Pression sonore poste Opérateur Presión sonora en la pos. del operador Ηχητική πίεση στη θέση του χειριστή Ljudtryck på operatörsplatsen	Pressão sonora na posição Operador Geluidsdruk op de werkplaats Operatör pozisyonunda ses basıncı	81 dB(A) (K= 4 dB)
---	---	---	------------------------------

EN 12549 :2009 EN ISO 3746 :2011 EN ISO 4871 :2009	Puissance sonore émise Potencia sonora emitida Εκπεμπόμενη ηχητική ισχύς	Potência sonora emitida Geëmitteerd geluidsvermogen Çıkan ses gücü (ses desibeli)	89 dB(A) (K= 4 dB)
---	--	---	------------------------------

CEN ISO/TS 8662-11 :2006 EN ISO 5349-2 :2004 EN 12096 :1999	Émission vibratoire sur la prise en main Emisión de vibraciones en la empuñadura Εκπεμπόμενες δονήσεις στη λαβή	Emissão vibratória na empunhadura Trillingsemisssie op de handgreep Tutamak üzerinde vibrasyon emisyonları	2,87 m/s² (K= 2 m/s ²)
--	---	--	---

Tipo di punto
Type of fastener
Befestigungsmittel
Type de rivet
Tipo de punto
Τύπος αναλωσίμου
Tipo de agrafo
Type nietjes
Zimba ve çivi tipleri
Typ av stygn

Brads B6

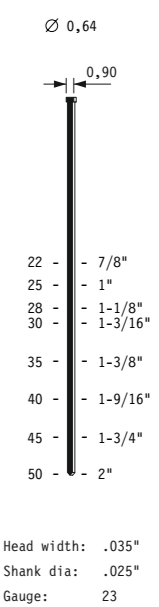

Caricamento - Loading - Laden - Chargement - Carga - Γέμισμα - Carregamento - Laden - Yükleme - Laddning

Caricamento dal fianco
Side load magazine

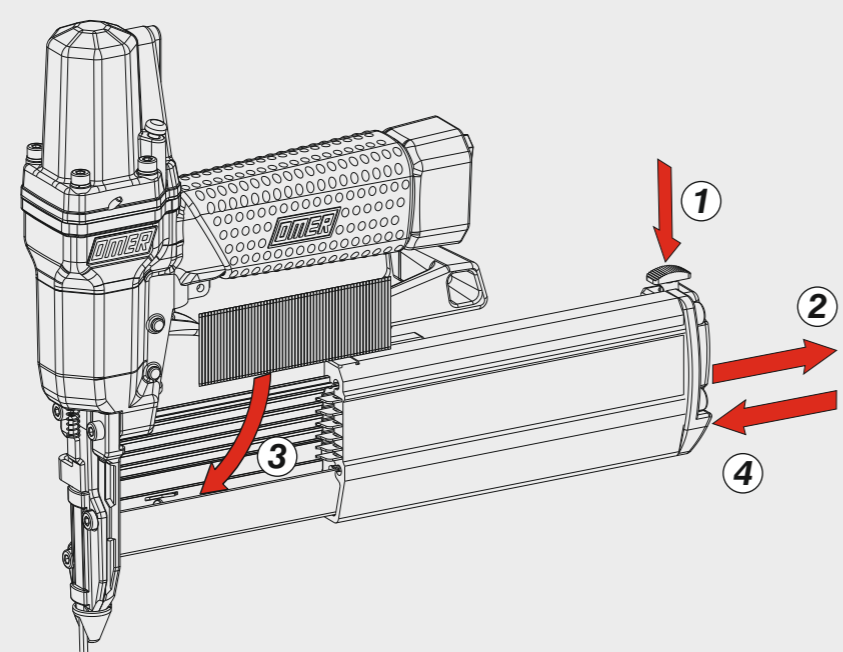

1140250N_B650N_1_rev21_02/02/2023_DV

Parti di ricambio - Spare parts - Ersatzteile - Pièces de rechange - Recambios
Ανταλλακτικά - Partes sobresselentes - Wisselstukken - Yedek parçalar - Reservdelar

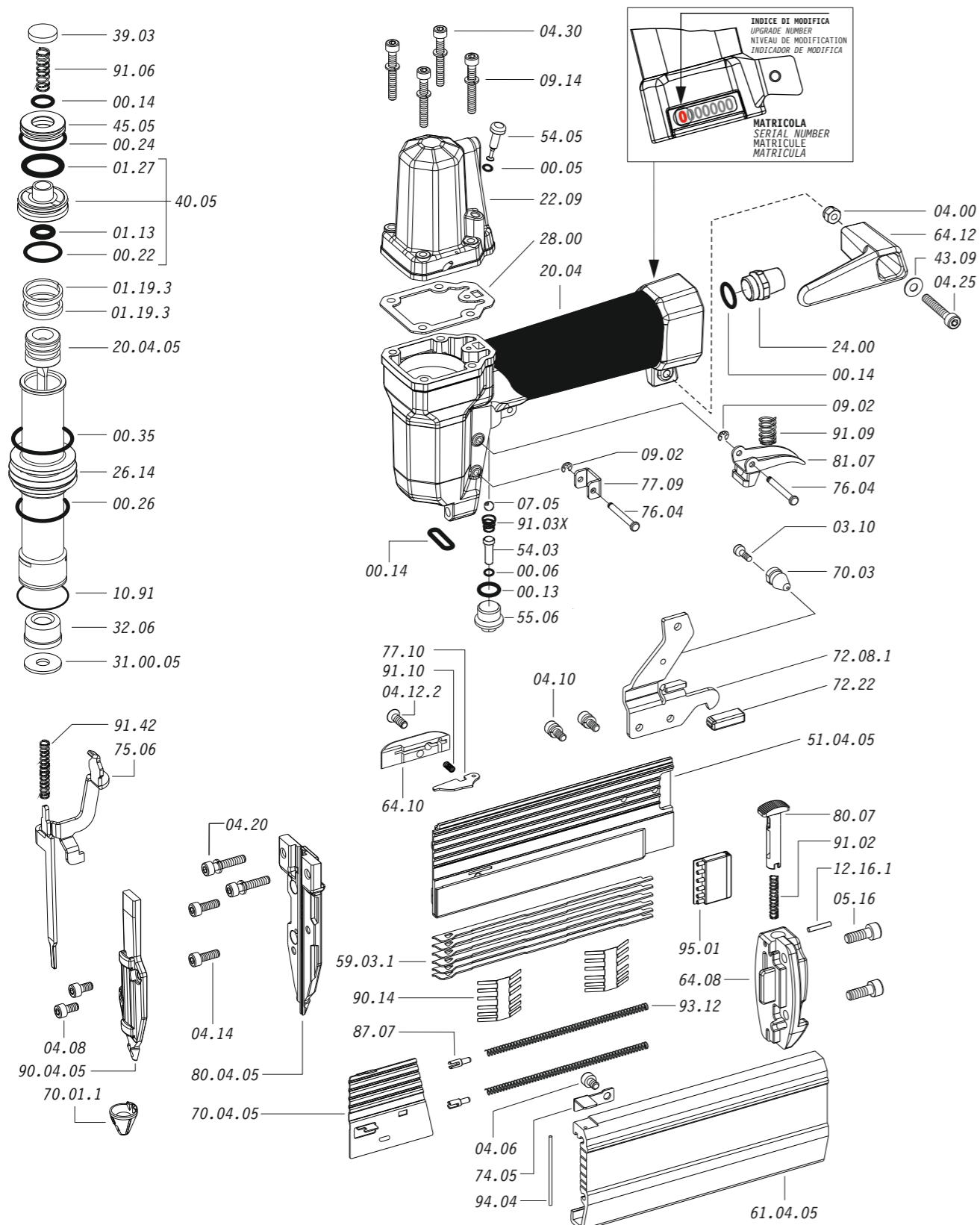

Dotazioni - Equipment - Ausstattung - Outillage - Dotaciones - Εξοπλισμός
Dotações - Uitrusting - Donanımlar - Utrustning

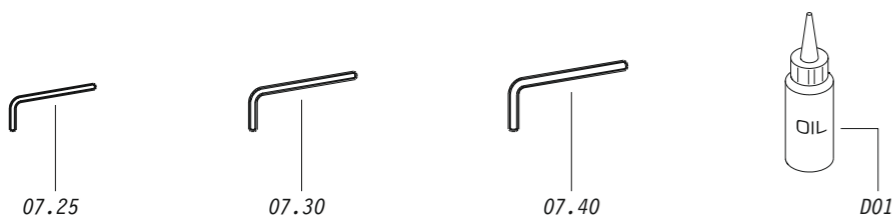

B6.50 N

cod. 1140250N

Parti di ricambio - Spare parts - Ersatzteile - Pièces de rechange - Recambios
Ανταλλακτικά - Partes sobresselentes - Wisselstukken - Yedek parçalar - Reservdelar

Cod.	Descrizione	Description
00.05	O-Ring	O-Ring
00.06	O-Ring	O-Ring
00.13	O-Ring	O-Ring
00.14	O-Ring	O-Ring
00.22	O-Ring	O-Ring
00.24	O-Ring	O-Ring
00.26	O-Ring	O-Ring
00.35	O-Ring	O-Ring
01.13	O-Ring	O-Ring
01.19.3	Guarnizione	Gasket
01.27	O-Ring	O-Ring
03.10	Vite	Screw
04.00	Dado	Nut
04.06	Vite	Screw
04.08	Vite	Screw
04.08.1	Vite	Screw
04.10	Vite	Screw
04.12.2	Vite	Screw
04.20	Vite	Screw
04.25	Vite	Screw
04.30	Vite	Screw
05.16	Vite	Screw
07.05	Sfera	Ball
07.25	Chiave esagonale	Hex. bar wrench
07.30	Chiave esagonale	Hex. bar wrench
07.40	Chiave esagonale	Hex. bar wrench
09.02	Anello elastico	Elastic ring
09.14	Anello elastico	Elastic ring
10.91	O-Ring	O-Ring
12.16.1	Spina	Pin
20.04	Corpo	Body
22.09	Testa	Head
24.00	Silenziatore	Silencer
26.14	Cilindro	Cylinder
28.00	Guarnizione	Gasket
32.06	Ammortizzatore	Bumper
39.03	Guarnizione scarico	Exhaust gasket
40.05	Valvola completa	Valve ass'y
43.09	Rondella	Washer
45.05	Anello valvola	Ring
54.03	Pulsante sparo	Trigger valve
54.05	Pulsante soffio	Air button
55.06	Raccordo	Bush
59.03.1	Distanziale	Spacer
64.08	Fondello	Cap
64.10	Carter	Carter
64.12	Gancio	Hanging-hook
70.01.1	Puntale	Contact tip
70.03	Supporto puntale	Contact tip support
72.08.1	Reggicaricatore	Support
72.22	Fermo carrello	Slider-stop
74.05	Fermo perno	Pin-stop
75.06	Sicura	Safety
76.04	Perno	Pin
77.09	Guida sicura	Safety guide
77.10	Blocco sicura	Safety block
80.07	Grilletto chiusura	Trigger lock
81.07	Grilletto comando	Trigger
87.07	Portamolla	Spring bearing
90.14	Molla	Spring
91.02	Molla	Spring
91.03X	Molla	Spring
91.06	Molla	Spring
91.09	Molla	Spring
91.10	Molla	Spring
91.42	Molla	Spring
93.12	Molla	Spring
94.04	Perno	Pin
95.01	Scatola molle	Spring box
20.04.05	Battente	Driver
31.00.05	Rondella	Washer
51.04.05	Caricatore	Magazine
61.04.05	Carrello	Slider
70.04.05	Spingipunto	Pusher
80.04.05	Controtestina	Nose
90.04.05	Testina	Nose plate
D01	Bocchetta olio	Oiler

Guarnizioni - O-Rings - Dichtungen - Joints toriques - Juntas - Δακτύλιος στεγανοποίησης - Vedantes - O-ringen - Contalar - O-ringar

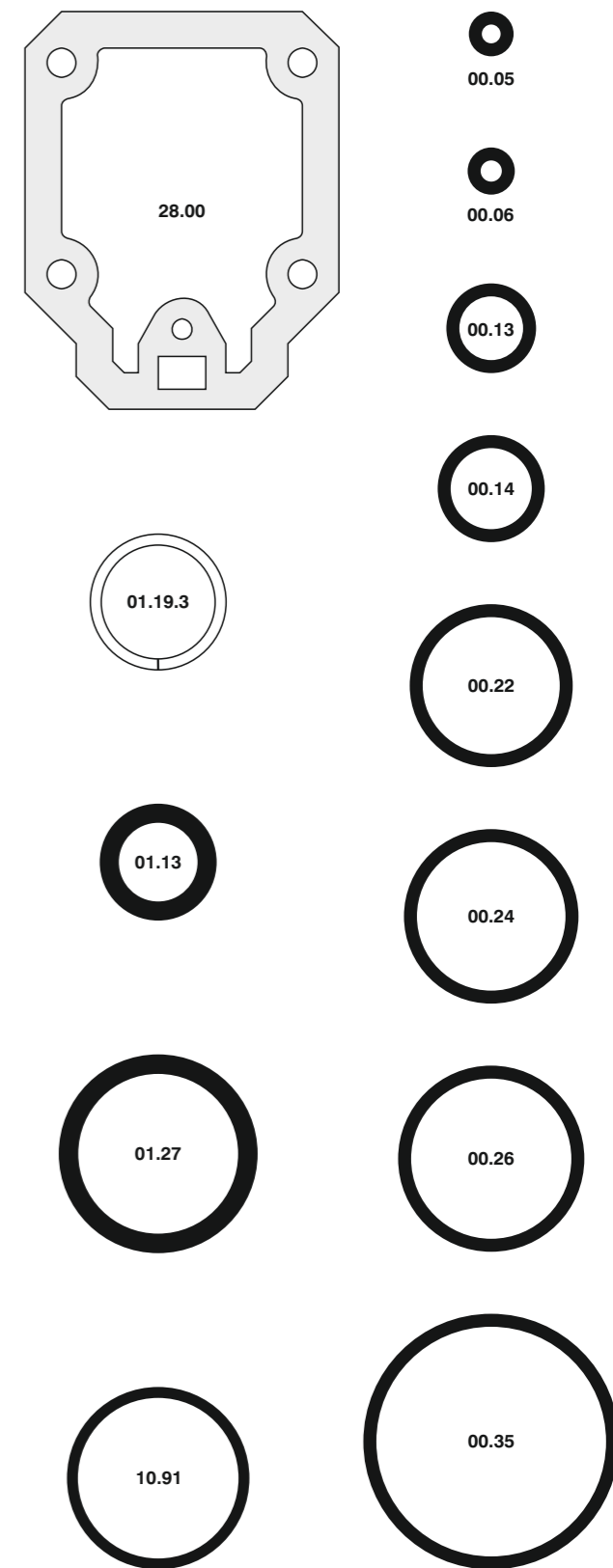

00.70.9

B6.50 N

cod. 1140250N

Indice di modifica
Upgrade number

1

Azionamento sequenziale singolo
Single sequential actuation

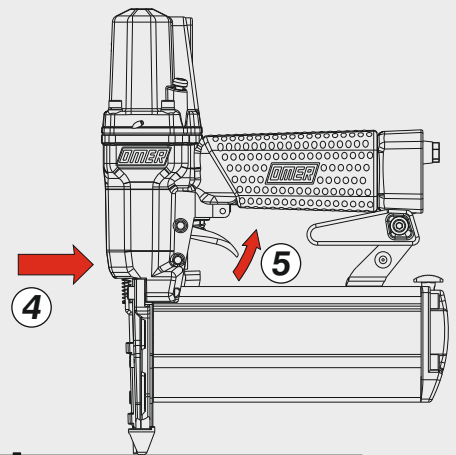
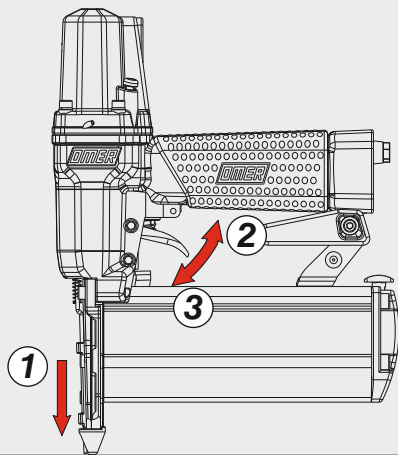

Disinceppamento - Jam clearing - Staubeseitigung - Décoincement - Desatascamiento - Απεμπλοκή
Desencravamento - Deblokkering bij vastlopen - Sıkışma giderme - Rensning av igensättningar

