

Azionamento singolo con doppia attivazione
 Single actuation with dual activation

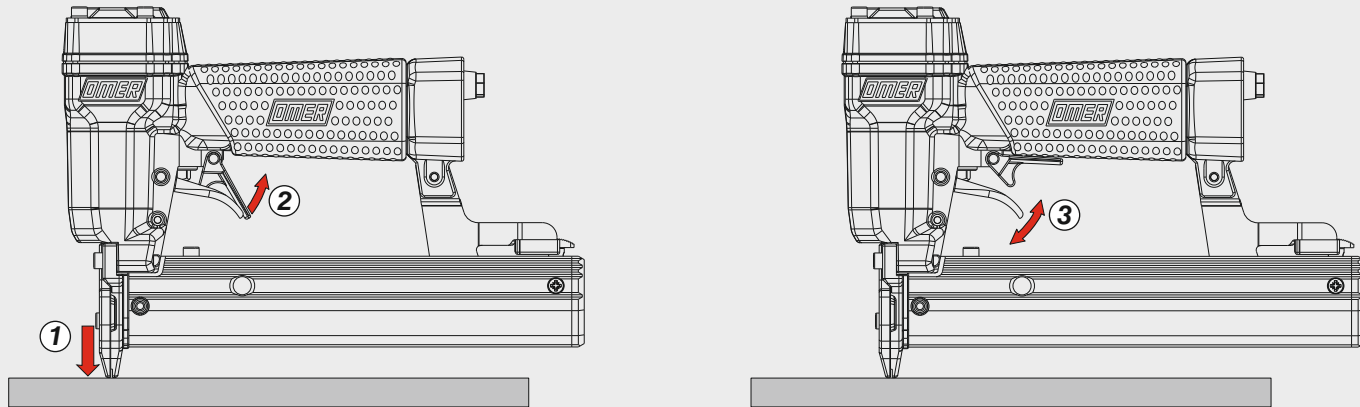

Caricamento - Loading - Laden - Chargement - Carga - Γέμισμα - Carregamento - Laden - Yükleme - Laddning

Caricamento da sopra
 Top load magazine

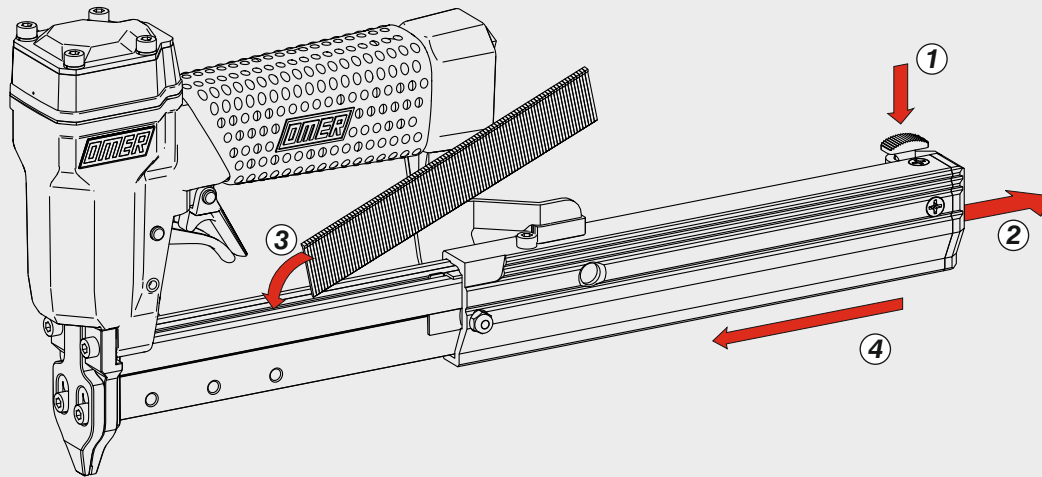

Caratteristiche - Features - Merkmale - Caractéristiques - Características - Χαρακτηριστικά
 Características - Kenmerken - Özellikler - Funktionen

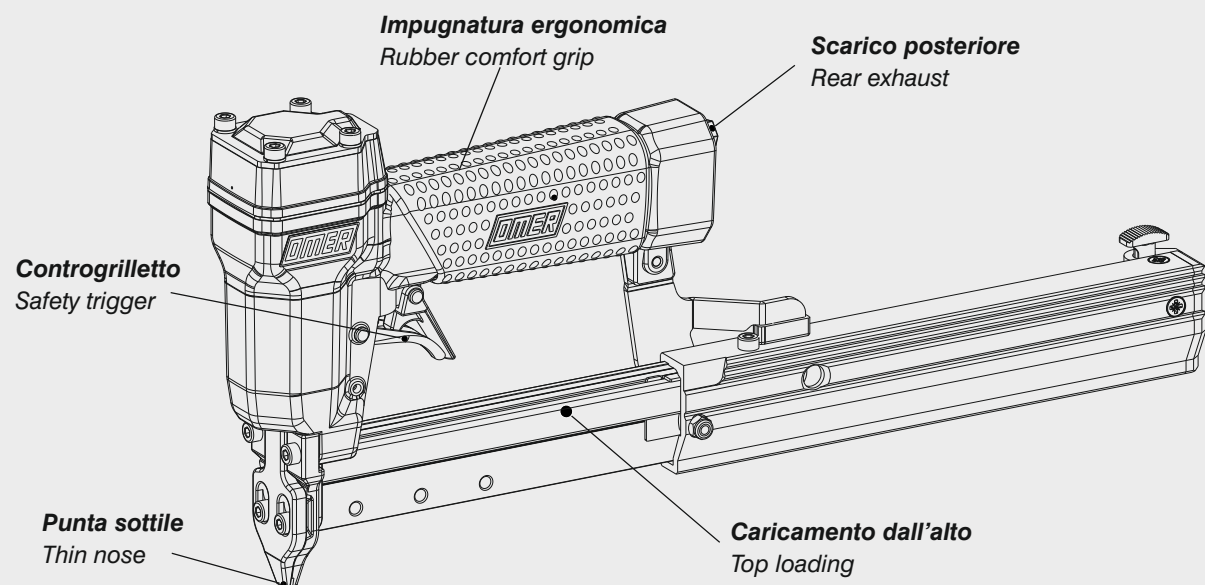

Manuale d'uso, manutenzione e parti di ricambio	Parte 2
Manual for use, maintenance and spare parts	Part 2
Bedienungs- und Wartungshandbuch sowie Ersatzteilleiste	Teil 2
Mode d'emploi, de maintenance et pièces de rechange	Partie 2
Manual de uso, mantenimiento y recambios	Part 2
Εγχειρίδιο χρήσης, συντήρησης και ανταλλακτικών	Μέρος 2
Manual de uso, manutenção e peças sobresselentes	Parte 2
Handleiding voor gebruik, onderhoud en wisselstukken	Deel 2
Kullanım, bakım ve yedek parça kılavuzu	Kısım 2
Användar-, underhålls- och reservdelshandbok	Del 2



12.28

cod. 1141220



Dati tecnici Technical data Technische Daten Tekniska data	Caractéristiques techniques Datos técnicos Τεχνικά χαρακτηριστικά	Dados técnicos Technische gegevens Teknik veriler
---	---	---

Misure impiegabili Lengths Verwendbare Nagellänge Dimensioner som kan användas	Dimensions utiles Medidas de longitud Μήκος Αναλωσίμου	Medidas utilizáveis Toepasbare afmetingen Boy	10 ÷ 28
Capacità caricatore n° punti Magazine capacity Magazinkapazität: Nägel Magasinkapacitet: Antal punkter	Capacité chargeur n° de points Capacidad cargador n° puntos Δυνατότητα γεμιστέρα	Capacidade carregador n° pontos Capaciteit magazijn in aantal spijkers Dergi kapasitesi	100
Pressione d'esercizio Operating pressure Betriebsdruck Drifttryck	Pression d'exercice Presión de servicio Πίεση λειτουργίας	Pressão de serviço Werkdruk Çalışma basıncı	4,5 ÷ 6 bar 65 ÷ 90 psi
Consumo aria Air consumption Luftverbrauch Luftförbrukning	Consommation d'air Consumo aire Κατανάλωση αέρα	Consumo ar Luchtverbruik Hava tüketimi	0,15
Peso Weight Gewicht Vikt	Poids Peso Βάρος	Peso Gewicht Ağırlık	1,04

Dimensioni Dimensions Abmessungen Dimensioner (AxBxH)	Dimensions Dimensiones Διαστάσεις	Dimensões Afmetingen Boyutlar	230x43x163 (LxWxH)
---	---	-------------------------------------	------------------------------

EN 12549 :2009 EN ISO 4871 :2009 Pressione sonora in pos. operatore Sound pressure in operator's position Schalldruck am Arbeitsplatz Ljudtryck på operatörsplatsen	Pression sonore poste Opérateur Presión sonora en la pos. del operador Ηχητική πίεση στη θέση του χειριστή	Pressão sonora na posição Operador Geluidsdruk op de werkplaats Operatör pozisyonunda ses basıncı	80 dB(A) (K= 4 dB)
---	--	---	------------------------------

EN 12549 :2009 EN ISO 3746 :2011 EN ISO 4871 :2009 Potenza sonora emessa Sound power emitted Emitierte Schalleistung Avgiven ljudeffekt	Puissance sonore émise Potencia sonora emitida Εκπεμπόμενη ηχητική ισχύς	Potência sonora emitida Geëmitteerd geluidsvermogen Çıkan ses gücü (ses desibeli)	86 dB(A) (K= 4 dB)
---	--	---	------------------------------

CEN ISO/TS 8662-11 :2006 EN ISO 5349-2 :2004 EN 12096 :1999 Emissione vibratoria sull'impugnatura Vibratory emissions on handle Vibrationsmission am Griff Vibrationsemission på handtaget	Émission vibratoire sur la prise en main Emisión de vibraciones en la empuñadura Εκπεμπόμενες δονήσεις στη λαβή	Emissão vibratória na empunhadura Trillingsemissie op de handgreep Tutamak üzerindeki vibrasyon emisyonları	<2,5 m/s² (K= 2 m/s ²)
--	---	---	--

Tipo di punto
Type of fastener
Befestigungsmittel
Type de rivet
Tipo de punto
Τύπος αναλωσίμου
Tipo de agrafo
Type nietjes
Zimba ve çivi tipleri
Typ av stygn

Brads 12

1x1,25

1,9

10 - 3/8"

28 - 1-1/8"

Head width: .075"

Gauge: 18

Parti di ricambio - Spare parts - Ersatzteile - Pièces de rechange - Recambios
Ανταλλακτικά - Partes sobresselentes - Wisselstukken - Yedek parçalar - Reservdelar

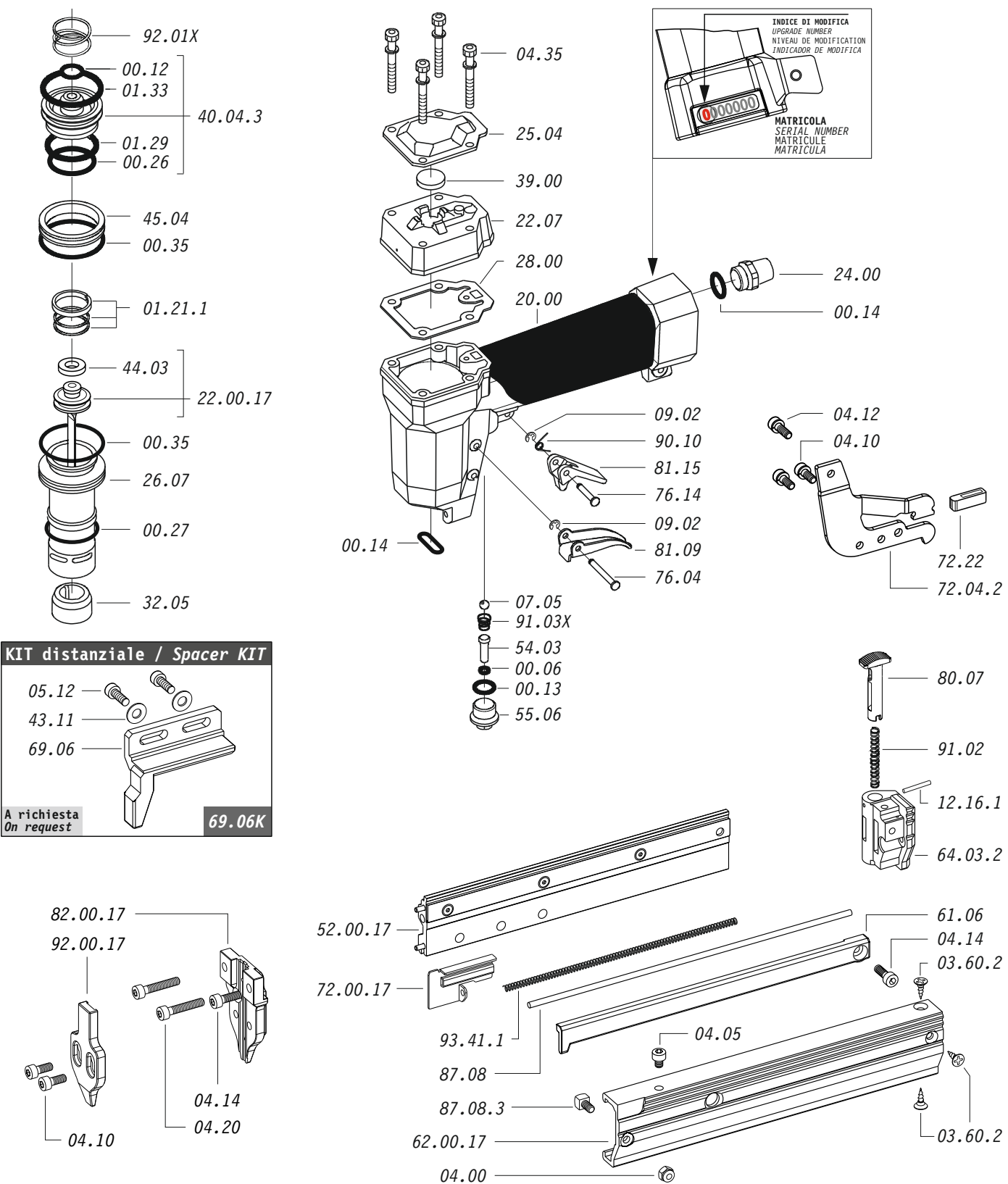

Dotazioni - Equipment - Ausstattung - Outillage - Dotaciones - Εξοπλισμός
Dotações - Uitrusting - Donanımlar - Utrustning



12.28

cod. 1141220

Parti di ricambio - Spare parts - Ersatzteile - Pièces de rechange - Recambios
Ανταλλακτικά - Partes sobresselentes - Wisselstukken - Yedek parçalar - Reservdelar

Cod.	Descrizione	Description
00.06	O-Ring	O-Ring
00.12	O-Ring	O-Ring
00.13	O-Ring	O-Ring
00.14	O-Ring	O-Ring
00.26	O-Ring	O-Ring
00.27	O-Ring	O-Ring
00.35	O-Ring	O-Ring
01.21.1	Guarnizione	Gasket
01.29	O-Ring	O-Ring
01.33	O-Ring	O-Ring
03.60.2	Vite	Screw
04.00	Dado	Nut
04.05	Vite	Screw
04.10	Vite	Screw
04.12	Vite	Screw
04.14	Vite	Screw
04.20	Vite	Screw
04.35	Vite	Screw
05.12	Vite	Screw
07.05	Sfera	Ball
07.30	Chiave esagonale	Hex. bar wrench
09.02	Anello elastico	Elastic ring
12.16.1	Spina	Pin
20.00	Corpo	Body
22.07	Testa	Head
24.00	Silenziatore	Silencer
25.04	Deflettore	Deflector
26.07	Cilindro	Cylinder
28.00	Guarnizione	Gasket
32.05	Ammortizzatore	Bumper
39.00	Guarnizione scarico	Exhaust gasket
40.04.3	Valvola completa	Valve ass'y
43.11	Rondella	Washer
44.03	Ammortizzatore	Bumper
45.04	Anello valvola	Ring
54.03	Pulsante sparo	Trigger valve
55.06	Raccordo	Bush
61.06	Guida Dx	Right Guide
64.03.2	Fondello	Cap
69.06	Distanziale	Spacer
69.06K	KIT Distanziale	Spacer KIT
72.04.2	Reggicaricatore	Support
72.22	Fermo carrello	Slider-stop
76.04	Perno	Pin
76.14	Perno	Pin
80.07	Grilletto chiusura	Trigger lock
81.09	Grilletto comando	Trigger
81.15	Controgrilletto	Safety
87.08	Portamolla	Spring bearing
87.08.3	Supporto	Support
90.10	Molla	Spring
91.02	Molla	Spring
91.03X	Molla	Spring
92.01X	Molla	Spring
93.41.1	Molla	Spring
22.00.17	Battente	Driver
52.00.17	Caricatore	Magazine
62.00.17	Carrello	Slider
72.00.17	Spingipunto	Pusher
82.00.17	Controtestina	Nose
92.00.17	Testina	Nose plate
D01	Bocchetta olio	Oiler

Guarnizioni - O-Rings - Dichtungen - Joints toriques - Junta - Δακτύλιος στεγανοποίησης - Vedantes - O-ringen - Contalar - O-ringar

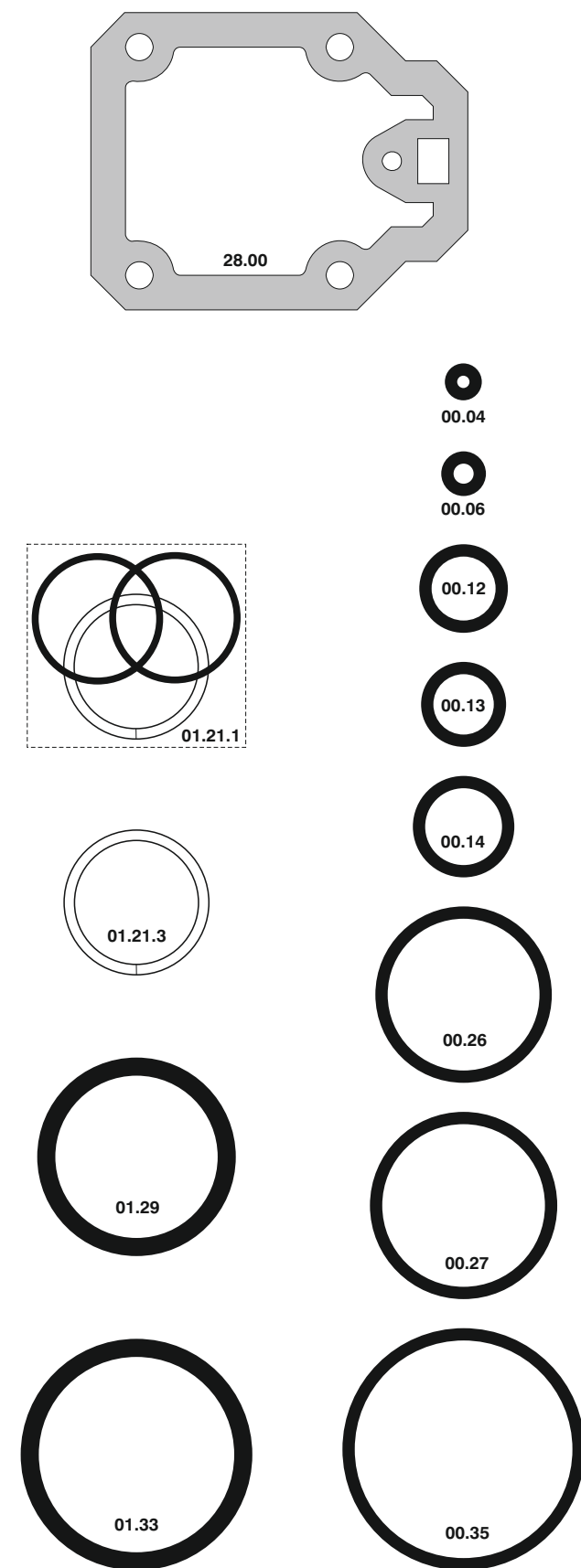

cod. 1141220

Indice di modifica
Upgrade number

4

12.28

Disincceppamento - Jam clearing - Staubeseitigung - Décoincement - Desatascamiento - Απεμπλοκή
Desencravamento - Deblokkering bij vastlopen - Sikişma giderme - Rensning av igensättningar

