

Manuale d'uso, manutenzione e parti di ricambio	Parte 2
Manual for use, maintenance and spare parts	Part 2
Bedienungs- und Wartungshandbuch sowie Ersatzteilleiste	Teil 2
Mode d'emploi, de maintenance et pièces de rechange	Partie 2
Manual de uso, mantenimiento y recambios	Part 2
Εγχειρίδιο χρήσης, συντήρησης και ανταλλακτικών	Μέρος 2
Manual de uso, manutenção e peças sobresselentes	Parte 2
Handleiding voor gebruik, onderhoud en wisselstukken	Deel 2
Kullanım, bakım ve yedek parça kılavuzu	Kısım 2
Användar-, underhålls- och reservdelshandbok	Del 2

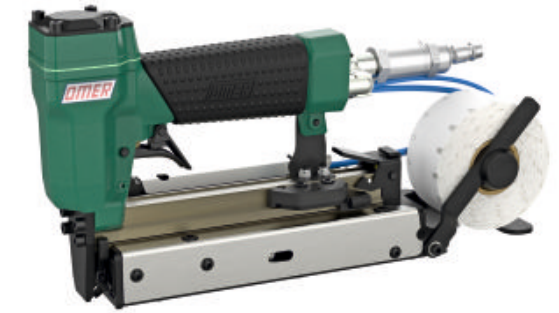

80.16 ET

cod. 11460130ET



Dati tecnici Technical data Technische Daten Tekniska data	Caractéristiques techniques Datos técnicos Τεχνικά χαρακτηριστικά	Dados técnicos Technische gegevens Teknik veriler
--	---	---

Misure impiegabili Lengths Verwendbare Nagellänge Dimensioner som kan användas	Dimensions utiles Medidas de longitud Μήκος Αναλωσίμου	Medidas utilizáveis Toepasbare afmetingen Boy	8 ÷ 16
Capacità caricatore n° punti Magazine capacity Magazinkapazität Nägel Magasinkapacitet Antal punkter	Capacité chargeur n° de points Capacidad cargador n° puntos Δυνατότητα γεμιστέρα	Capacidade carregador n° pontos Capaciteit magazijn in aantal spijkers Dergi kapasitesi	145 (600 ÷ 800 labels)
Pressione d'esercizio Operating pressure Betriebsdruck Drifttryck	Pression d'exercice Presión de servicio Πίεση λειτουργίας	Pressão de serviço Werkdruk Çalışma basıncı	5,5 ÷ 6,5 bar 80 ÷ 95 psi
Consumo aria Air consumption Luftverbrauch Luftförbrukning	Consommation d'air Consumo aire Κατανάλωση αέρα	Consumo ar Luchtverbruik Hava tüketimi	0,18
Peso Weight Gewicht Vikt	Poids Peso Βάρος	Peso Gewicht Ağırlık	2,23
Dimensioni Dimensions Abmessungen Dimensioner (AxBxH)	Dimensions Dimensiones Διαστάσεις	Dimensões Afmetingen Boyutlar	308x86x160 (LxWxH)

EN 12549 :2009 EN ISO 4871 :2009	Pressione sonora in pos. operatore Sound pressure in operator's position Schalldruck am Arbeitsplatz Ljudtryck på operatörsplatsen	Pression sonore poste Opérateur Presión sonora en la pos. del operador Ηχητική πίεση στη θέση του χειριστή Operatör pozisyonunda ses basıncı	81 dB(A) (K= 4 dB)
---	--	---	-------------------------------------

EN 12549 :2009 EN ISO 3746 :2011 EN ISO 4871 :2009	Potenza sonora emessa Sound power emitted Emitierte Schalleistung Avgiven ljudeffekt	Puissance sonore émise Potencia sonora emitida Εκπεμπόμενη ηχητική ισχύς	88 dB(A) (K= 4 dB)
---	--	--	-------------------------------------

CEN ISO/TS 8662-11 :2006 EN ISO 5349-2 :2004 EN 12096 :1999	Emissione vibratoria sull'impugnatura Vibratory emissions on handle Vibrationsemission am Griff Vibrationsemission på handtaget	Émission vibratoire sur la prise en main Emisión de vibraciones en la empuñadura Εκπεμπόμενες δονήσεις στη λαβή Tutamak üzerindeki vibrasyon emisyonları	<2,5 m/s² (K= 2 m/s²)
--	---	---	---

Tipo di punto
Type of fastener
Befestigungsmittel
Type de rivet
Tipo de punto
Τύπος αναλωσίμου
Tipo de agrafó
Type nietjes
Zimba ve çivi tipleri
Typ av stygn

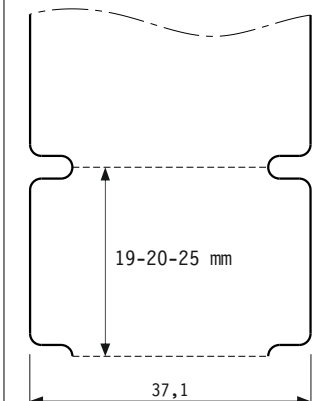
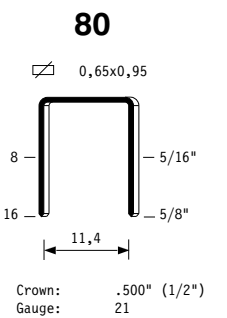

11460130ET_8016ET_4_rev21_16/02/2023 DV

Parti di ricambio - Spare parts - Ersatzteile - Pièces de rechange - Recambios
 Ανταλλακτικά - Partes sobresselentes - Wisselstukken - Yedek parçalar - Reservdelar

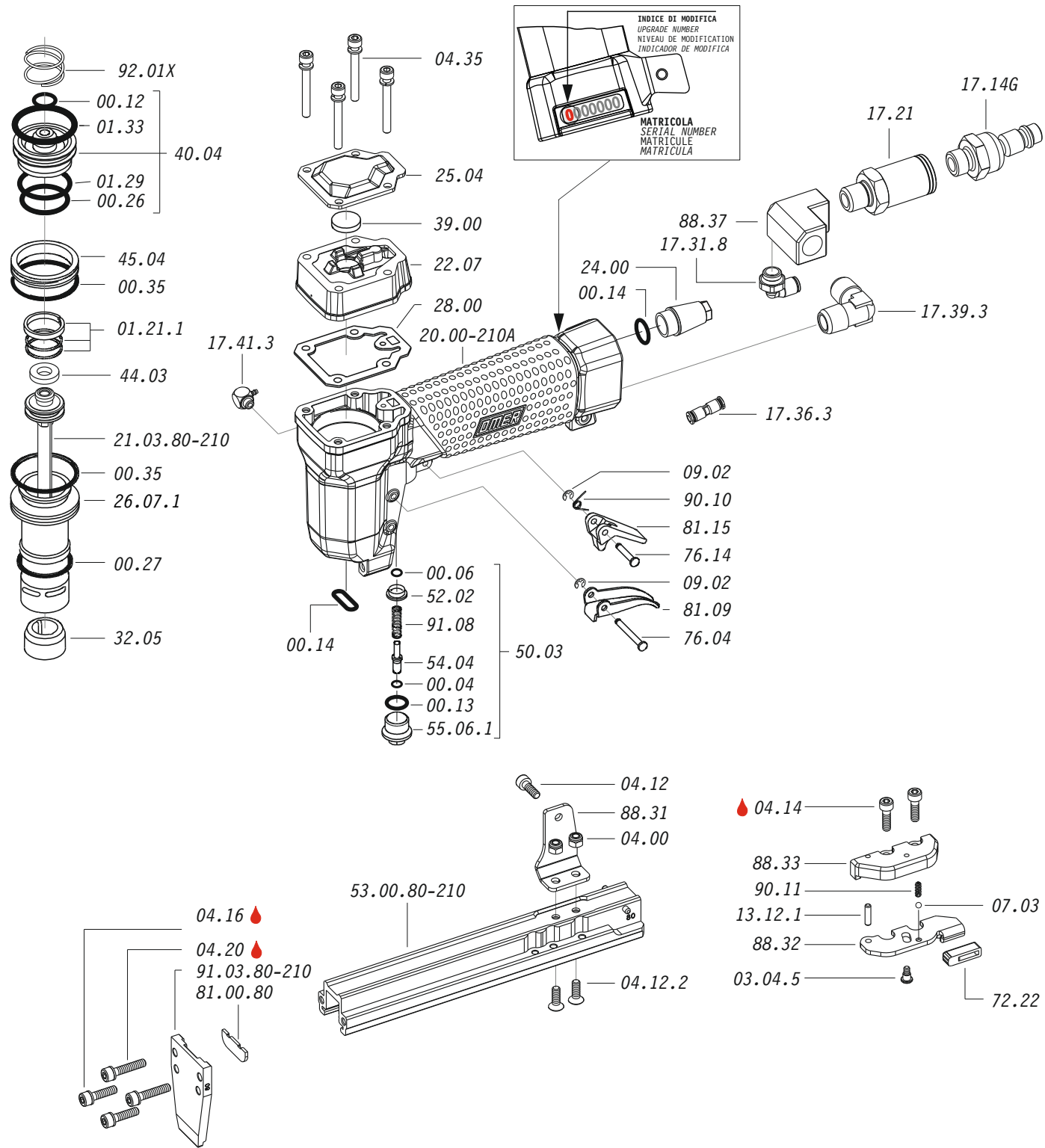

Dotazioni - Equipment - Ausstattung - Outillage - Dotaciones - Εξοπλισμός
 Dotações - Uitrusting - Donanimlar - Utrustning

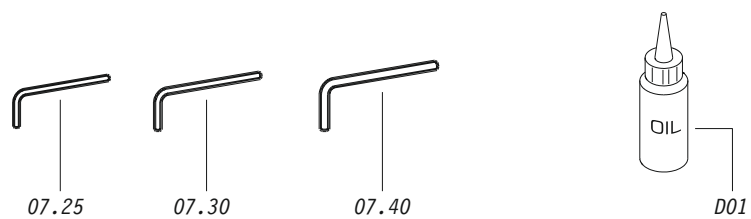

80.16 ET

cod. 11460130ET

Azionamento - Actuation - Auslösung - Actionnement - Accionamiento - Ενεργοποίηση
 Acionamento - Activering - Çalıştırma - Aktivering

Azionamento singolo con doppia attivazione
 Single actuation with dual activation

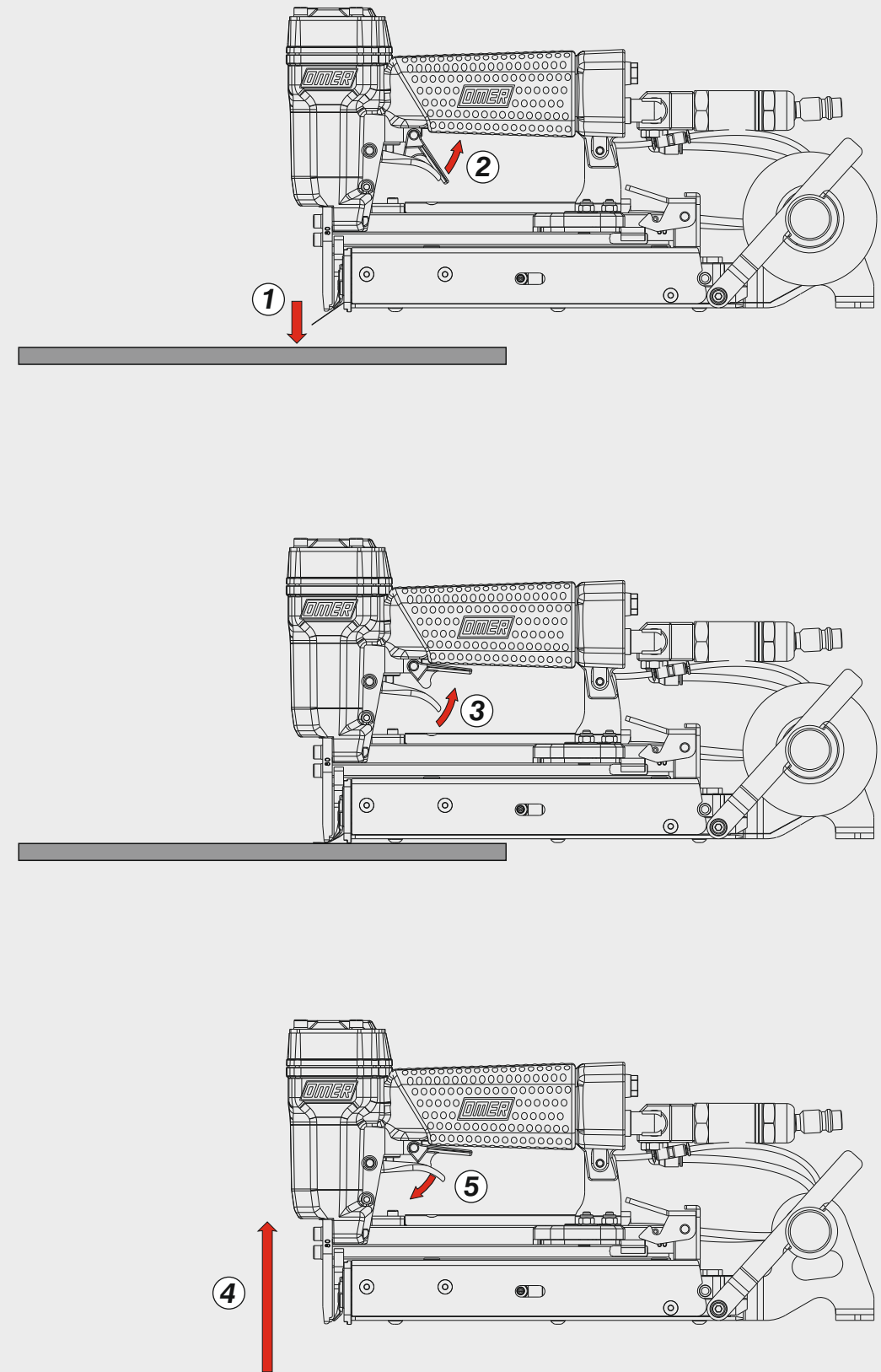

Regolazione velocità etichette - Labels speed adjustment

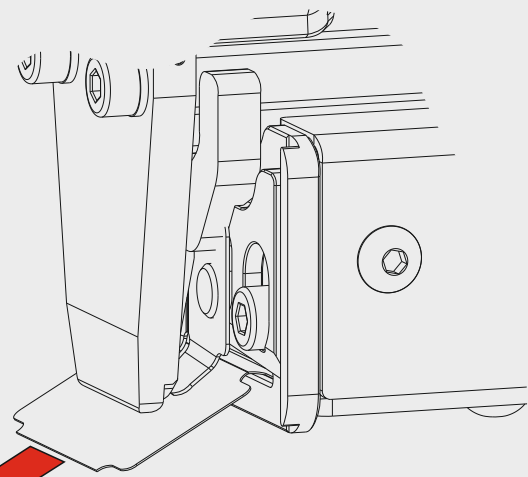
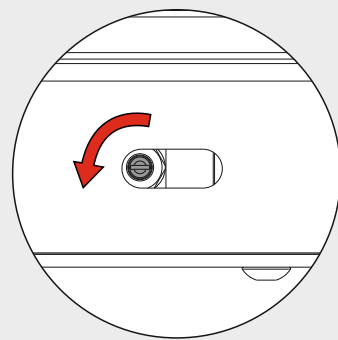
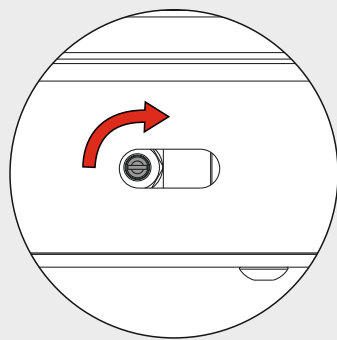
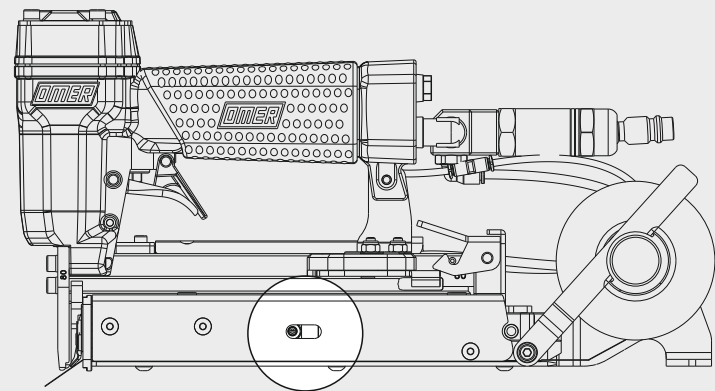

Parti di ricambio - Spare parts - Ersatzteile - Pièces de rechange - Recambios Ανταλλακτικά - Partes sobresselentes - Wisselstukken - Yedek parçalar - Reservdelar

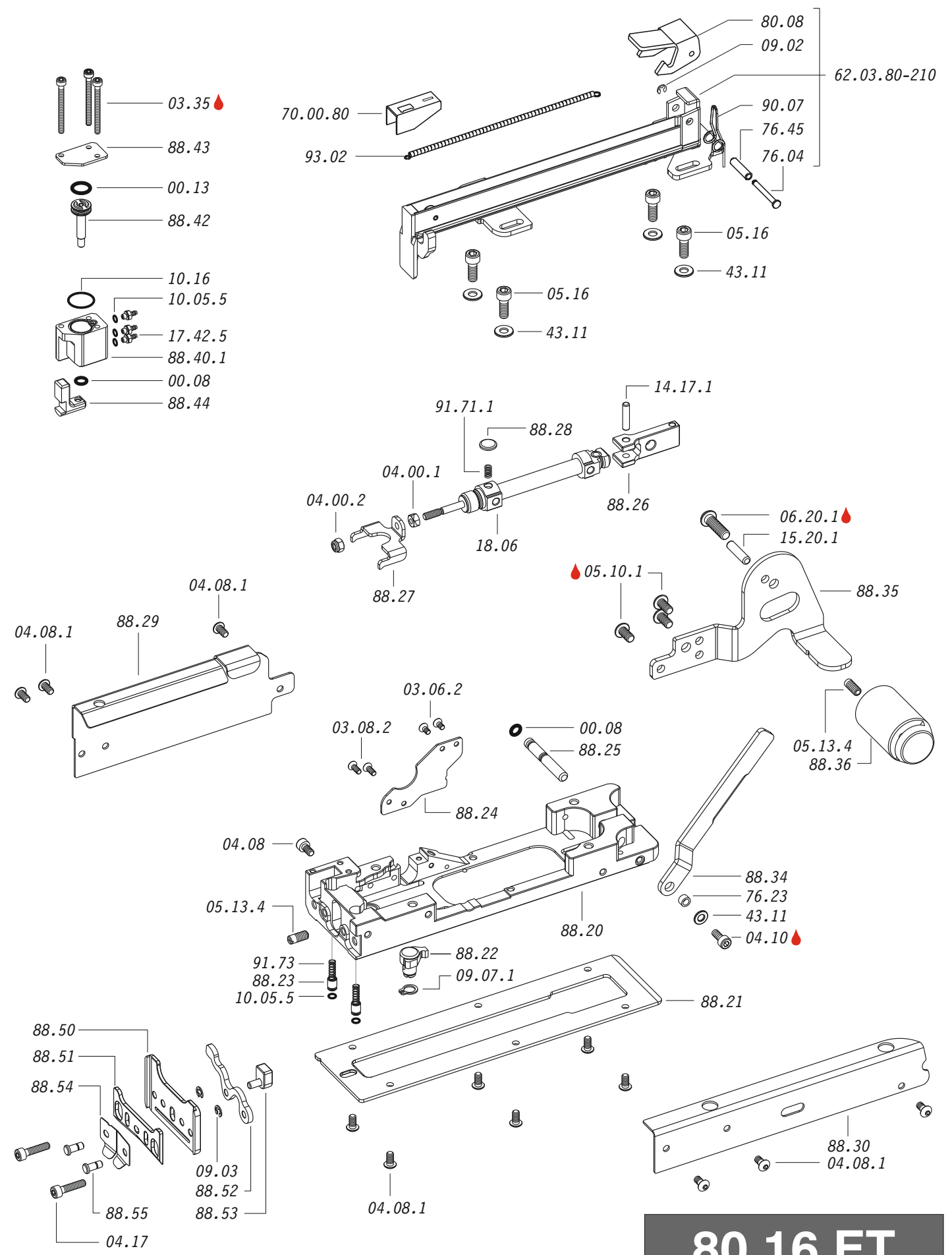

Apply Loctite 243

80.16 ET
cod. 11460130ET

Parti di ricambio - Spare parts - Ersatzteile - Pièces de rechange - Recambios
 Ανταλλακτικά - Partes sobresselentes - Wechselstukken - Yedek parçalar - Reservdelar

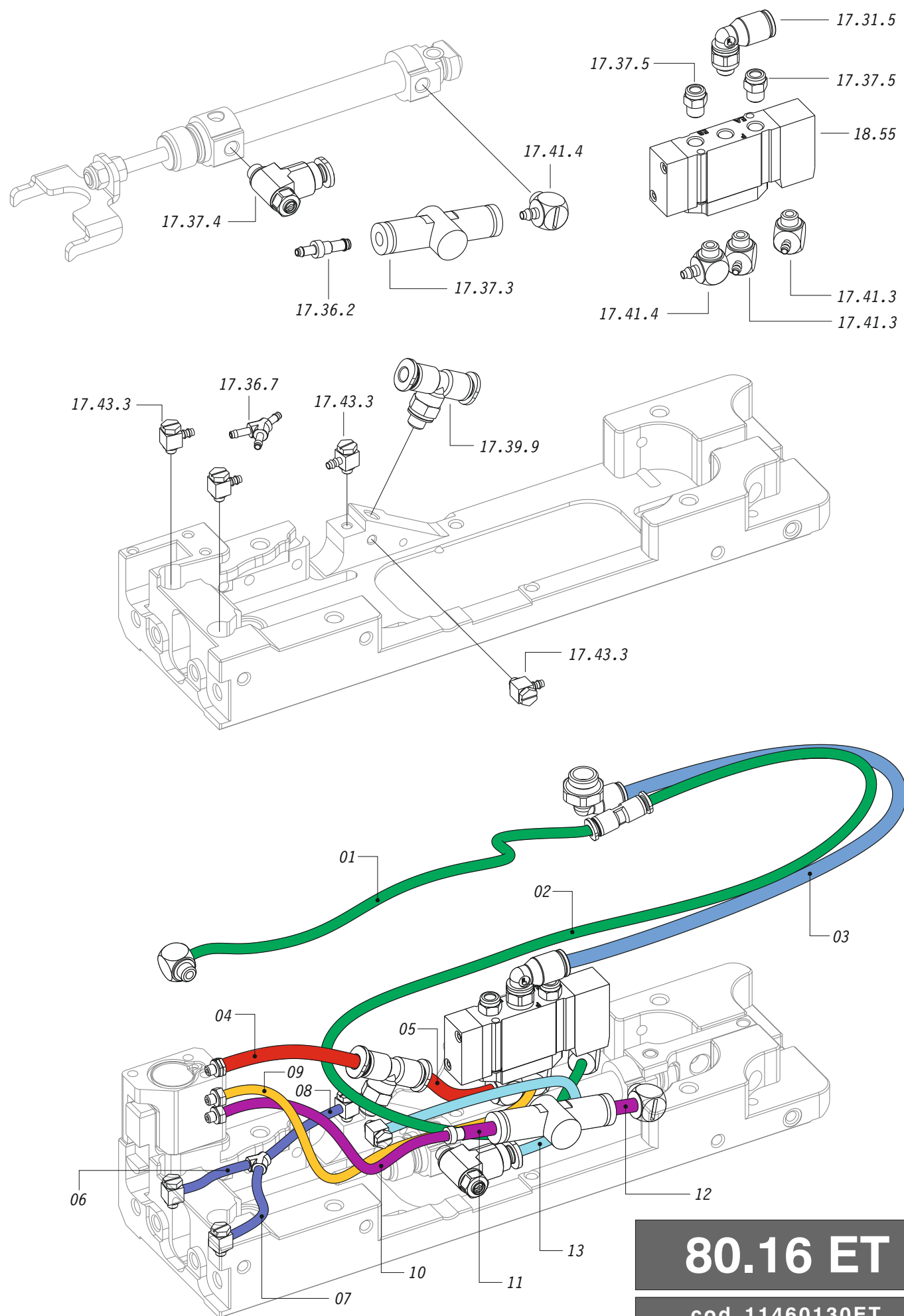

80.16 ET

cod. 11460130ET

Disinceppamento etichette - Label jam clearing

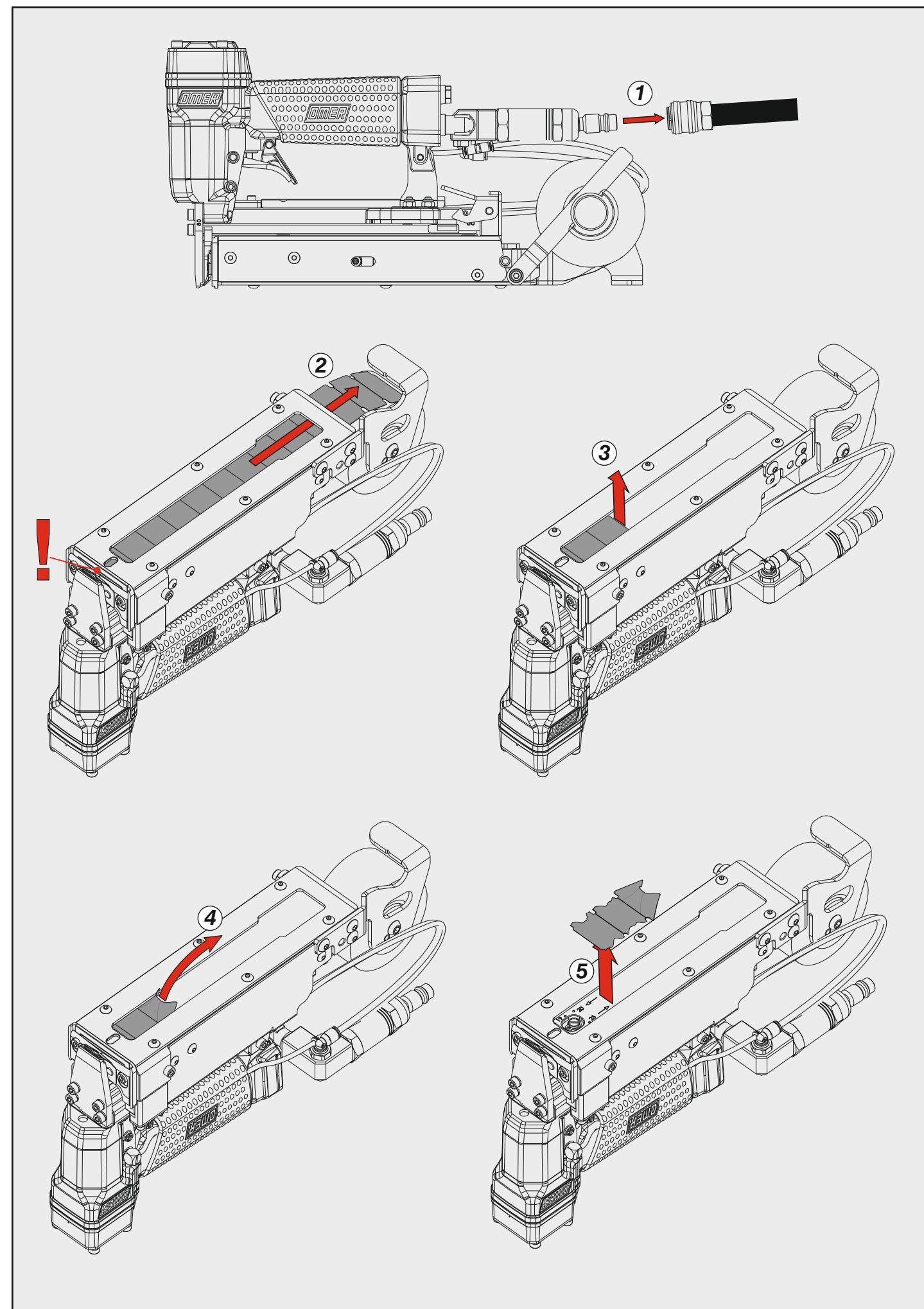

Sostituzione rapida caricatore - Fast magazine replacement

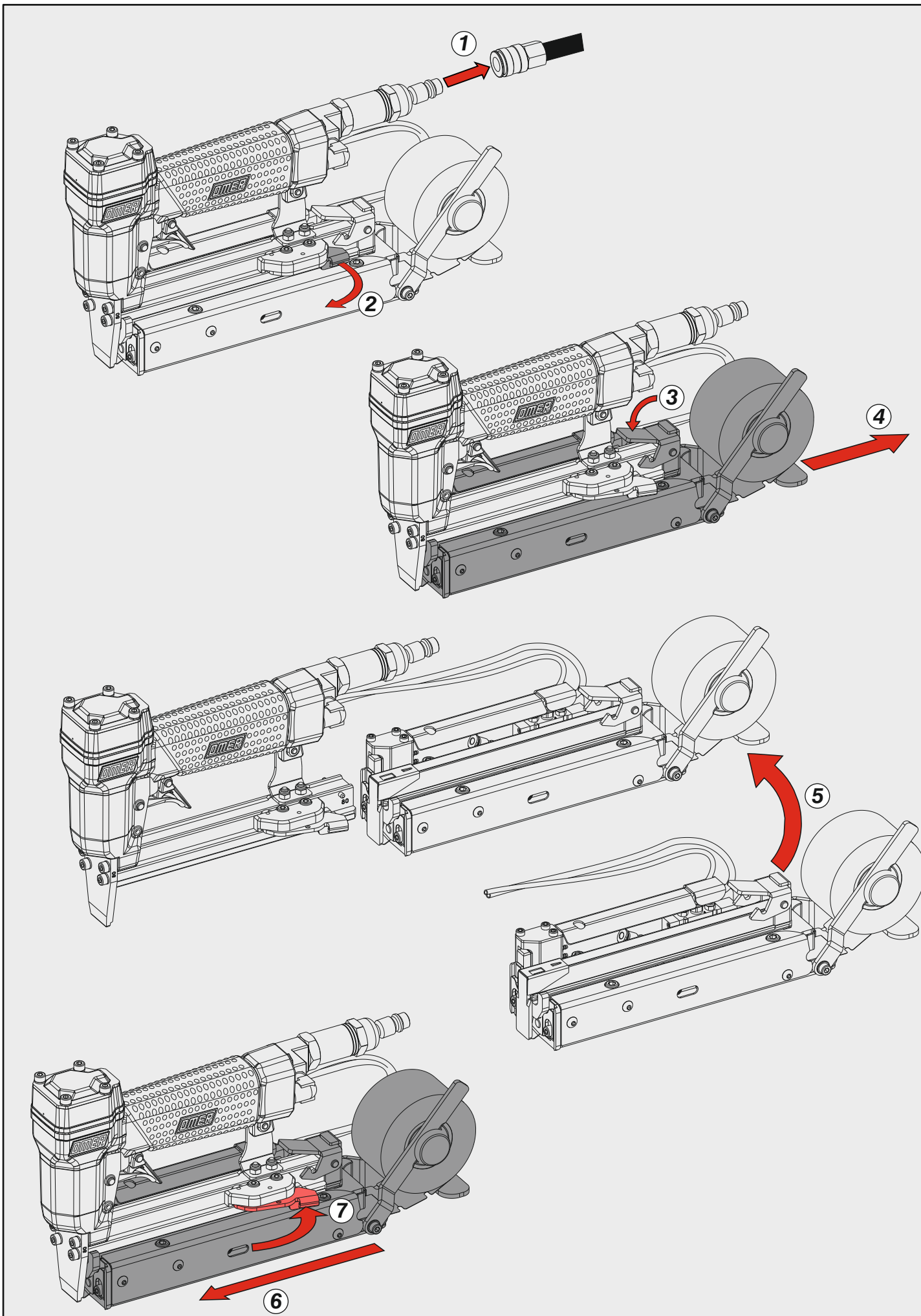

Parti di ricambio - Spare parts - Ersatzteile - Pièces de rechange - Recambios Ανταλλακτικά - Partes sobresselentes - Wisselstukken - Yedek parçalar - Reservdelar

Cod.	Descrizione	Description	Cod.	Descrizione	Description
00.04	O-Ring	O-Ring	24.00	Silenziatore	Silencer
00.06	O-Ring	O-Ring	25.04	Deflettore	Exhaust deflector
00.12	O-Ring	O-Ring	26.07.1	Cilindro	Cylinder
00.13	O-Ring	O-Ring	28.00	Guarnizione	Gasket
00.14	O-Ring	O-Ring	32.05	Ammortizzatore	Bumper
00.26	O-Ring	O-Ring	39.00	Guarnizione scarico	Exhaust gasket
00.27	O-Ring	O-Ring	40.04	Valvola completa	Valve ass'y
00.35	O-Ring	O-Ring	43.10Z	Rondella	Washer
01.21.1	Guarnizione	Gasket	43.11	Rondella	Washer
01.29	O-Ring	O-Ring	44.03	Ammortizzatore	Bumper
01.33	O-Ring	O-Ring	45.04	Anello valvola	Ring
03.04.5	Vite	Screw	50.03	Pulsante completo	Trigger valve ass'y
03.06.2	Vite	Screw	52.02	Boccola	Bush
03.08.2	Vite	Screw	54.04	Pulsante	Trigger valve
03.35	Vite	Screw	55.06.1	Raccordo	Bush
04.00	Dado	Nut	72.22	Fermo carrello	Slider Stop
04.00.1	Dado	Nut	76.04	Perno	Pin
04.00.2	Dado	Nut	76.14	Perno	Pin
04.08	Vite	Screw	76.23	Distanziale	Spacer
04.08.1	Vite	Screw	80.08	Grilletto chiuso	Trigger
04.10	Vite	Screw	81.09	Grilletto comando	Trigger
04.12	Vite	Screw	81.15	Controgrilletto	Safety
04.12.2	Vite	Screw	88.20	Piastra	Plate
04.14	Vite	Screw	88.21	Piastra inferiore	Bottom plate
04.16	Vite	Screw	88.22	Selettore	Selector
04.17	Vite	Screw	88.23	Pressore	Presser
04.20	Vite	Screw	88.24	Supporto valvola	Valve support
04.35	Vite	Screw	88.25	Perno	Pin
05.10.1	Vite	Screw	88.26	Supporto	Support
05.13.4	Grano a sfera	Grub screw	88.27	Forcella	Fork
05.16	Vite	Screw	88.28	Cappuccio	Cap
06.20.1	Vite	Screw	88.29	Carter sx	Left carter
07.03	Sfera	Ball	88.30	Carter dx	Right carter
07.25	Chiave esagonale	Hex. bar wrench	88.31	Reggicaricatore	Support
07.30	Chiave esagonale	Hex. bar wrench	88.32	Fermo carrello	Slider stop
07.30	Chiave esagonale	Hex. bar wrench	88.33	Supporto	Support
09.02	Anello elastico	Elastic ring	88.34	Staffa	Stirrup
09.03	Anello elastico	Elastic ring	88.35	Supporto	Support
09.07.1	Anello elastico	Elastic ring	88.36	Perno rotolo	Kingpin
10.05.5	O-Ring	O-Ring	88.37	Racc. curva	Conn. Elbow
10.16	O-Ring	O-Ring	88.40.1	Cilindro	Cylinder
13.12.1	Spina	Pin	88.42	Pistone	Piston
14.17.1	Spina	Pin	88.43	Tappo	Cap
15.20.1	Spina	Pin	88.44	Supporto	Support
17.14G	Attacco girevole	Swivel Connection	88.50	Lama fissa	Fixed blade
17.21	Filtro	Filter	88.51	Lama mobile	Mobile blade
17.31.5	Racc. "L" 4 - M5	Conn. "Elbow" 4 - M5	88.52	Leva Lama	Blade lever
17.31.8	Racc. "L" 4 - G1/8	Conn. "Elbow" 4 - M5	88.53	Supporto	Support
17.36.2	Racc. "D" 4 - 3	Conn. "Str" 4 - 3	88.54	Molla	Spring
17.36.3	Racc. "D" 3 - 3	Conn. "Str" 3 - 3	88.55	Perno	Pin
17.36.7	Racc. "Y" 3	Conn. "Y" 3	90.10	Molla	Spring
17.37.3	Scarico "D" 4 - 4	Exhaust "Str" 4 - 4	90.11	Molla	Spring
17.37.4	Regolatore portata	Flow regulator	91.08	Molla	Spring
17.37.5	Silenziatore	Silencer	91.71.1	Molla	Spring
17.39.5	Distributore curva	Elbow distributor	91.73	Molla	Spring
17.39.9	Racc. "T" 4 - M5	Conn. "Tee" 4 - M5	92.01X	Molla	Spring
17.41.3	Racc. "L" 3 - M5	Conn. "Elbow" 3 - M5	93.02	Molla	Spring
17.41.4	Racc. "L" 4 - M5	Conn. "Elbow" 4 - M5	21.03.80-210	Battente	Driver
17.42.5	Racc. "D" 4 - M4	Conn. "Str" 4 - M4	53.00.80-210	Caricatore	Magazine
17.43.3	Racc. "L" 3 - M3	Conn. "Elbow" 3 - M3	62.03.80-210	Carrello	Slider
18.06	Cilindro pneumatico	Pneumatic Cylinder	70.00.80	Spingipunto	Pusher
18.55	Valvola 5/2	5/2 Valve	81.00.80	Controtestina	Nose
20.00-210A	Corpo	Body	91.03.80-210	Testina	Nose plate
22.07	Testa	Head	D01	Bocchetta olio	Oiler

Guarnizioni - O-Rings - Dichtungen - Joints toriques - Juntas - Δακτύλιος στεγανοποίησης - Vedantes - O-ringen - Contalar - O-ringar

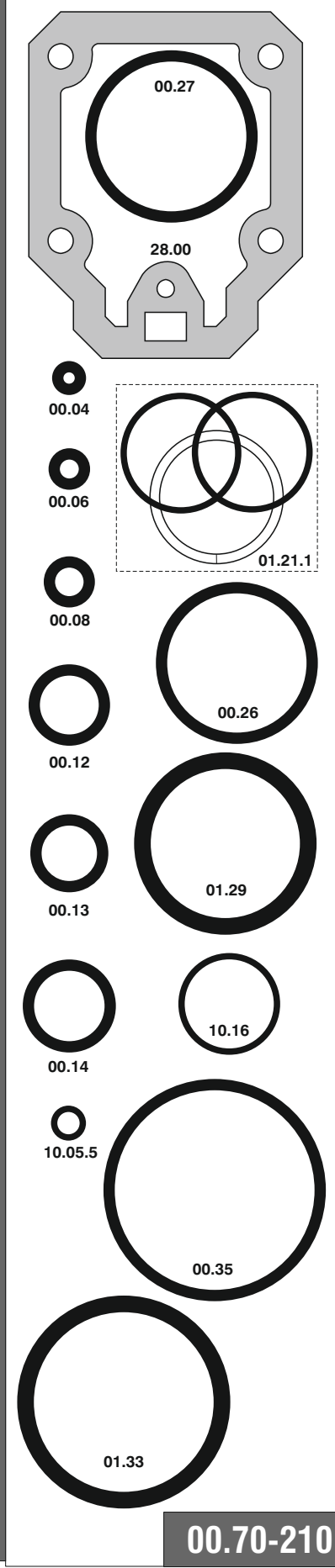

N°	Cod.	Ø (mm)	L (mm)	Dimensioni tubi Tubes dimensions
1	3TR32-01	3	140	
2	3TR32-02	3	460	
3	3TR42-03	4	210	
4	3TR42-04	4	60	
5	3TR42-05	4	38	
6	3TR32-06	3	21	
7	3TR32-07	3	33	
8	3TR32-08	3	34	
9	3TR32-09	3	115	
10	3TR32-10	3	80	
11	3TR42-11	4	25	
12	3TR42-12	4	25	
13	3TR32-13	3	77	

80.16 ET

cod. 11460130ET

Indice di modifica Upgrade number **4**

Caricamento etichette - Labels loading

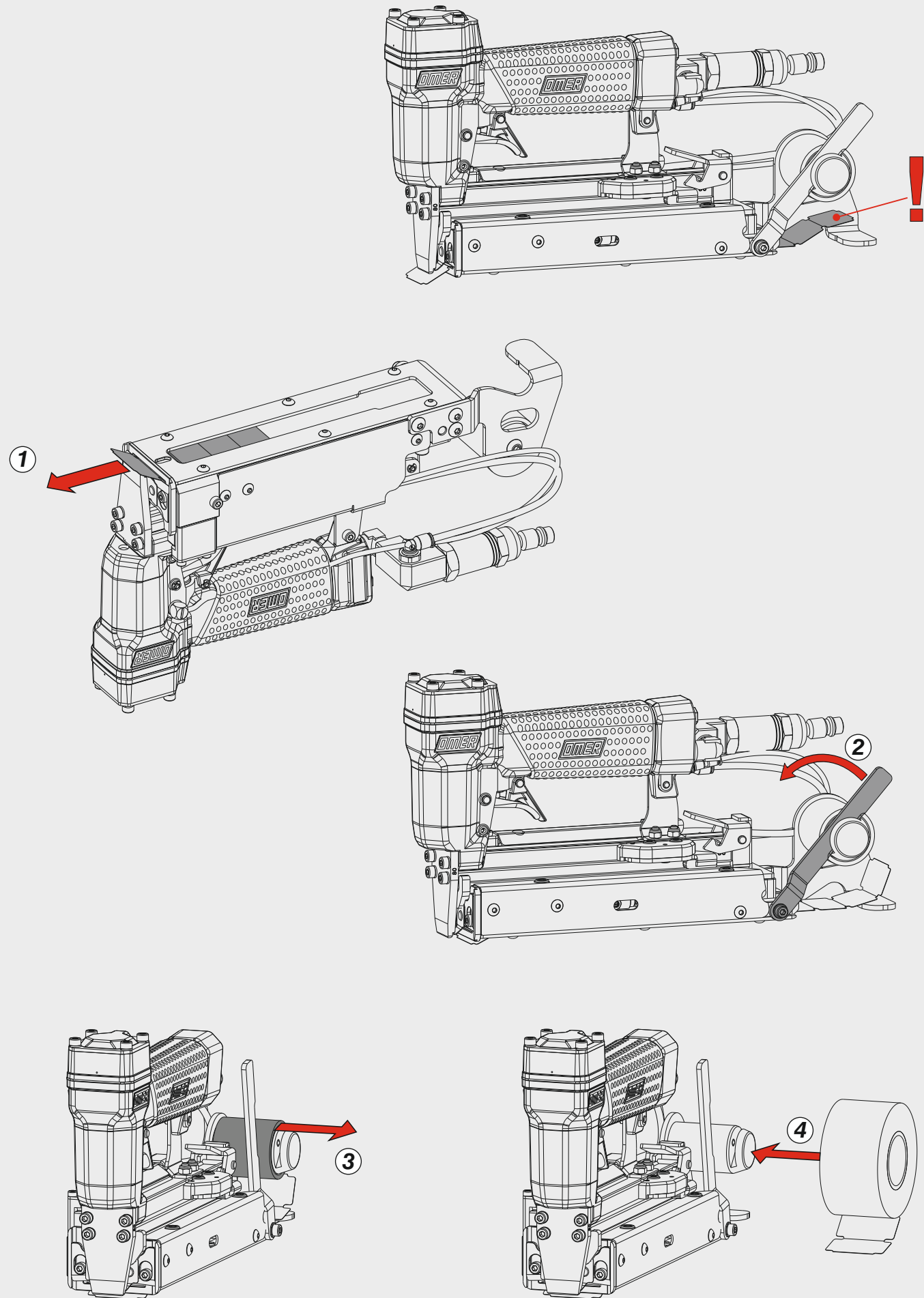

Regolazione posizione graffa - Staple position adjustment

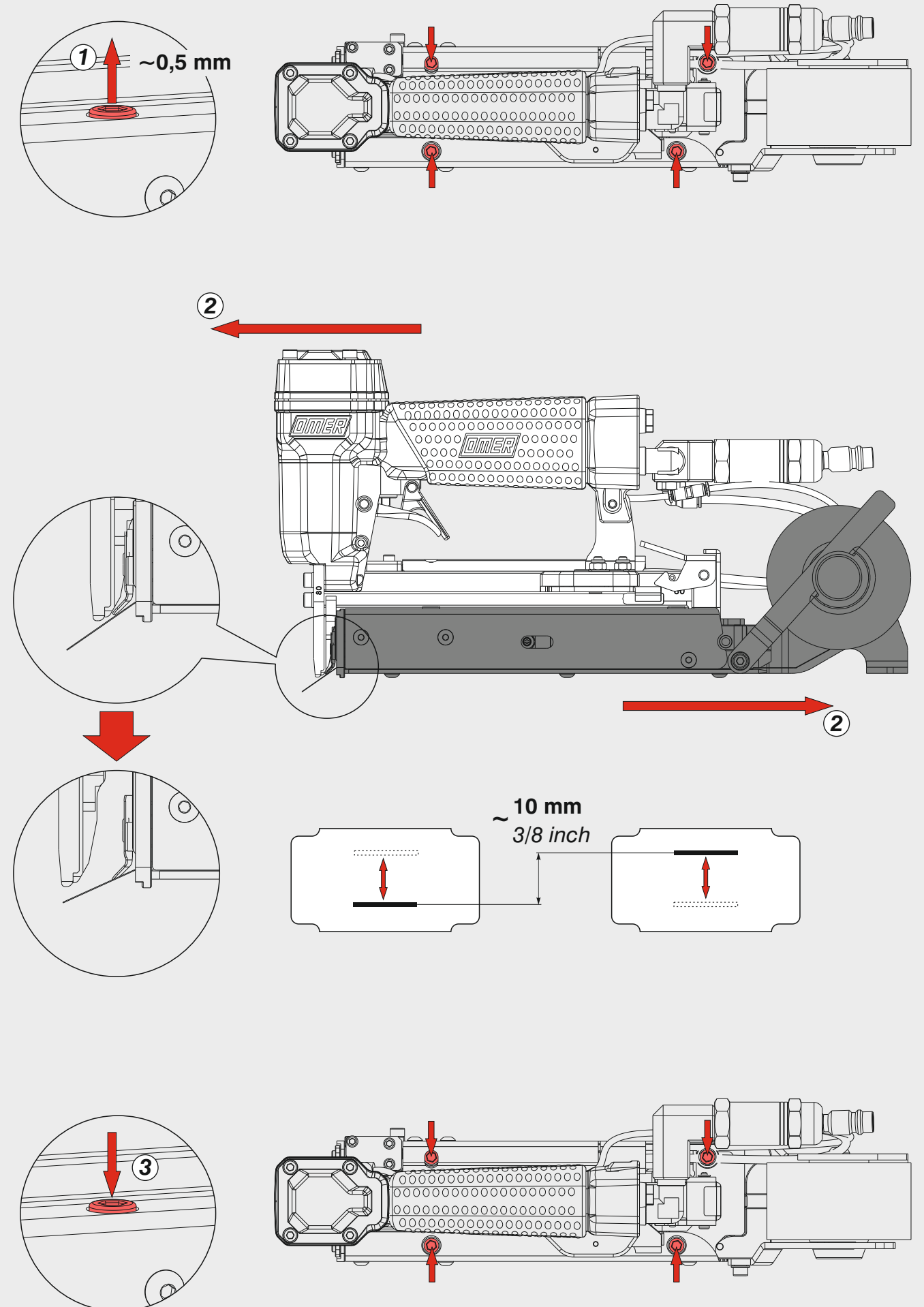

Caricamento graffe - Staple loading

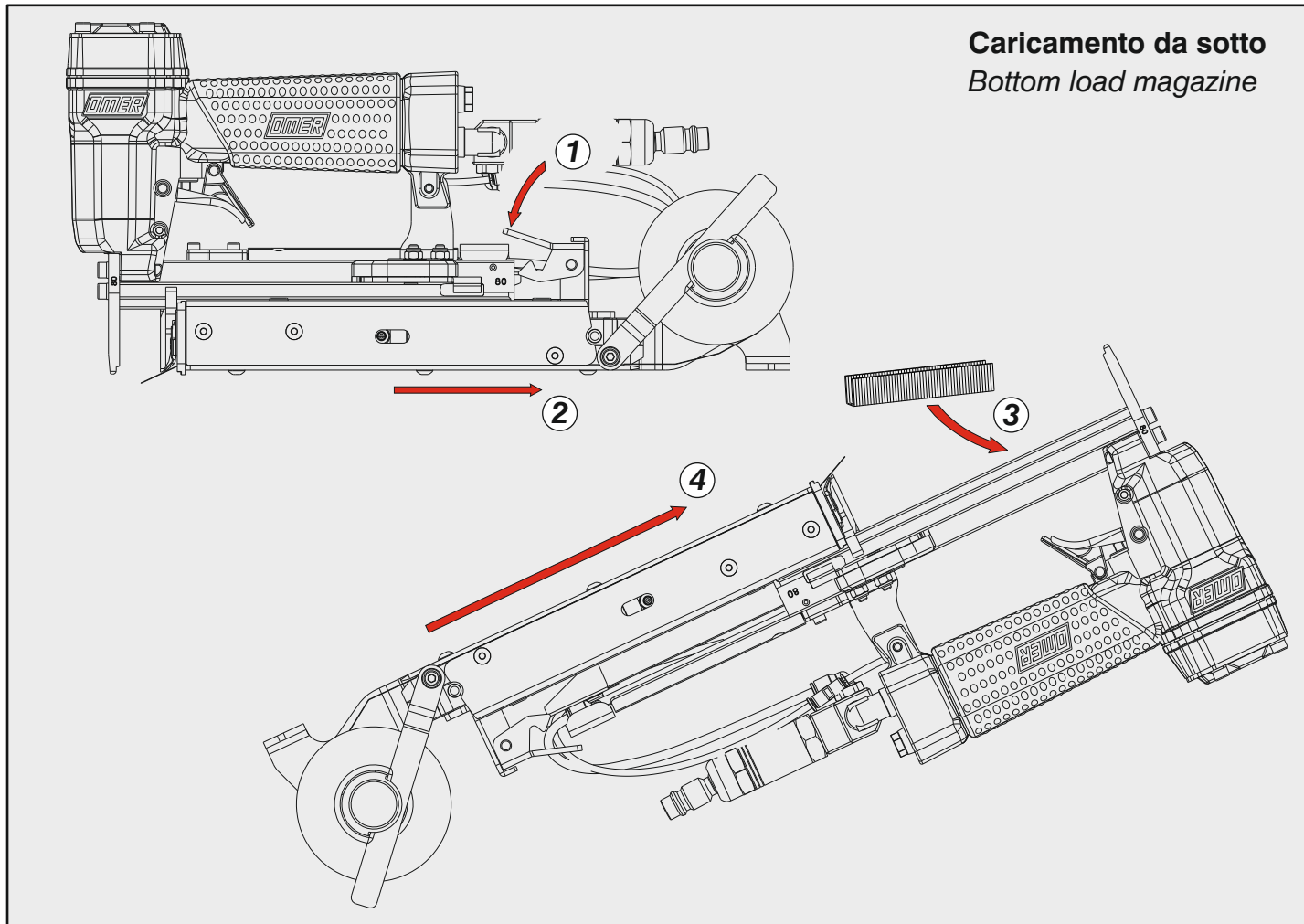

Disinceppamento graffa - Staple jam clearing

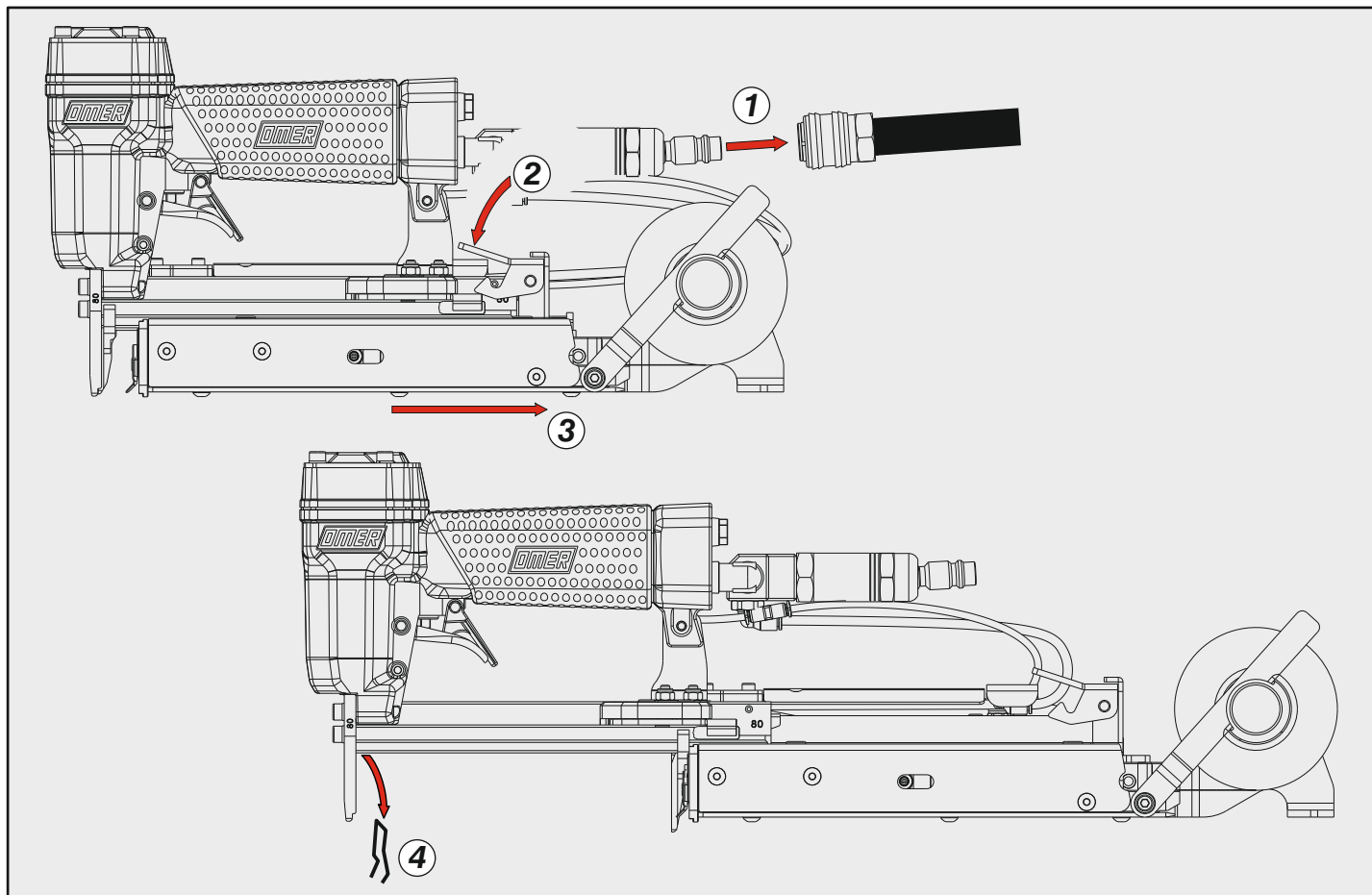

Caricamento etichette - Labels loading

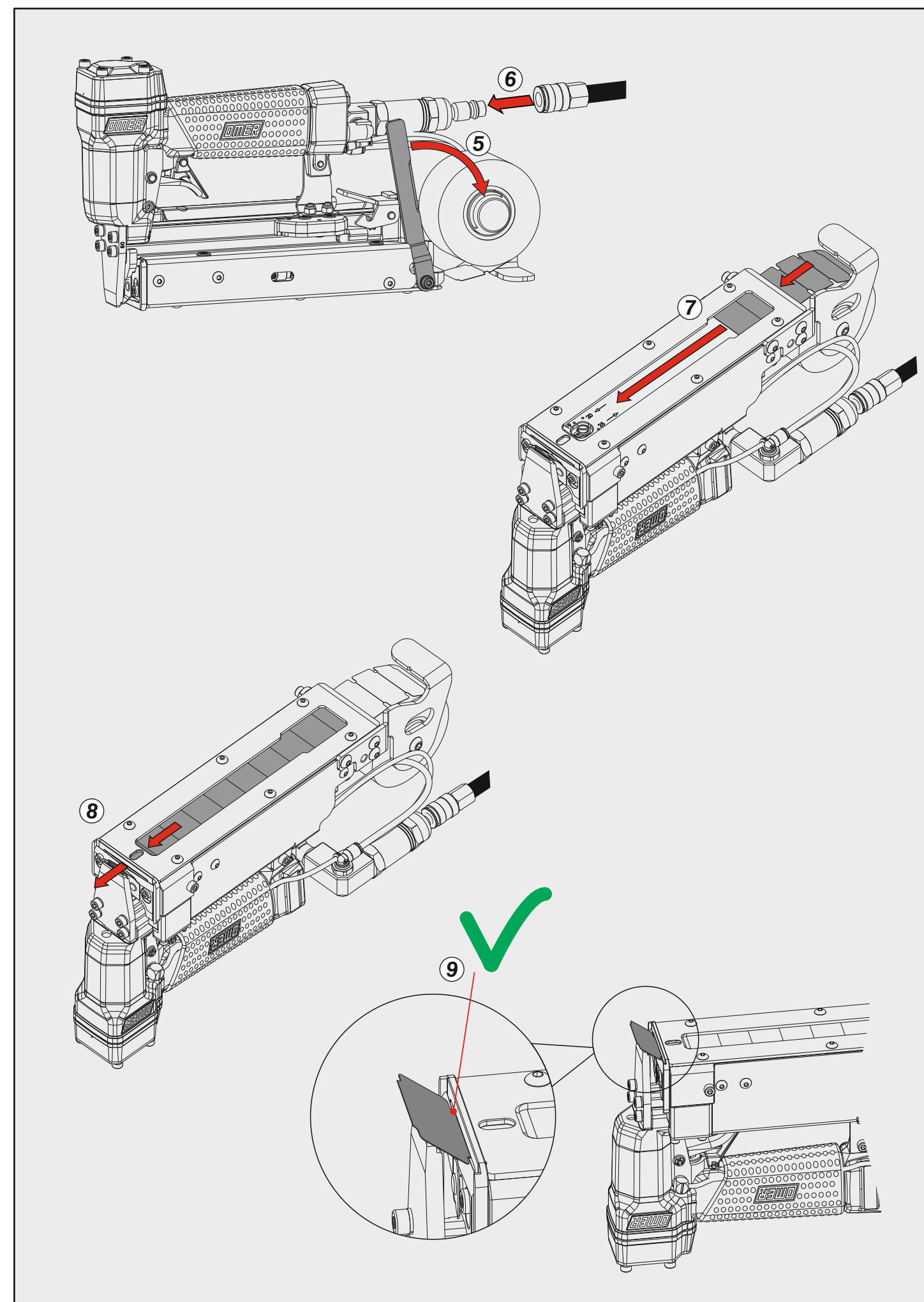

Regolazione misura etichetta - Staple length adjustment

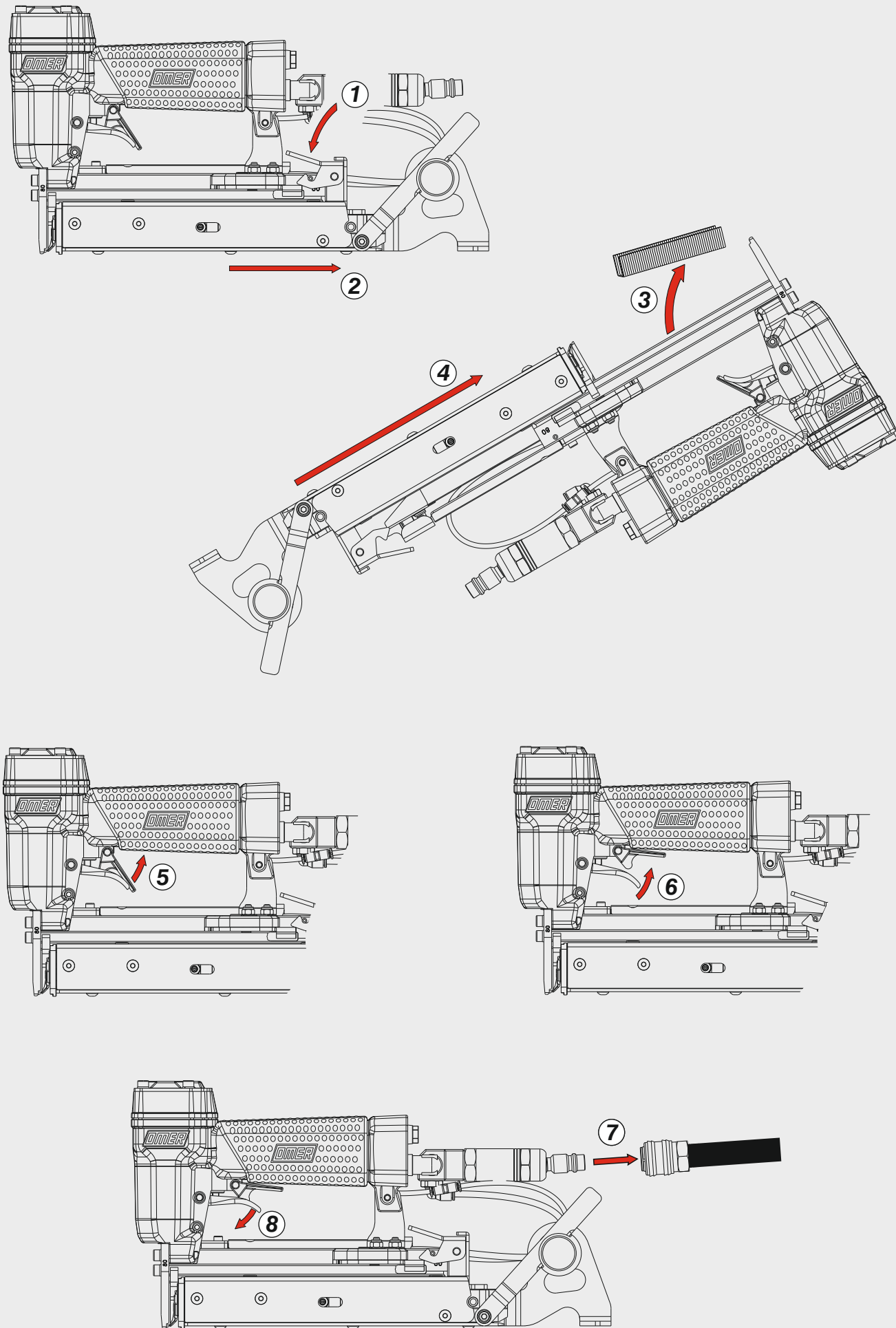

Regolazione misura etichetta - Staple length adjustment

