

Collegamento - Connection

Collegamento:
Connection:

Valvola 3/2 NC
Valve 3/2 NC

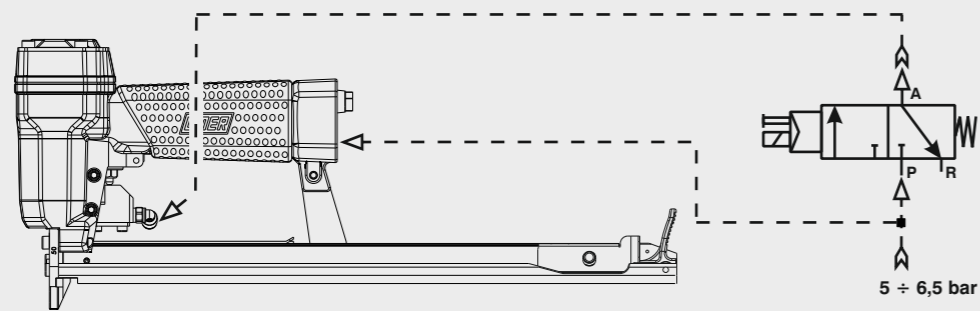

OMER

Manuale d'uso, manutenzione e parti di ricambio	Parte 2
Manual for use, maintenance and spare parts	Part 2
Bedienungs- und Wartungshandbuch sowie Ersatzteilleiste	Teil 2
Mode d'emploi, de maintenance et pièces de rechange	Partie 2
Manual de uso, mantenimiento y recambios	Part 2
Εγχειρίδιο χρήσης, συντήρησης και ανταλλακτικών	Μέρος 2
Manual de uso, manutenção e peças sobresselentes	Parte 2
Handleiding voor gebruik, onderhoud en wisselstukken	Deel 2
Kullanım, bakım ve yedek parça kılavuzu	Kısım 2
Användar-, underhålls- och reservdelshandbok	Del 2



Caricamento - Loading - Laden - Chargement - Carga - Γέμισμα - Carregamento - Laden - Yükleme - Laddning

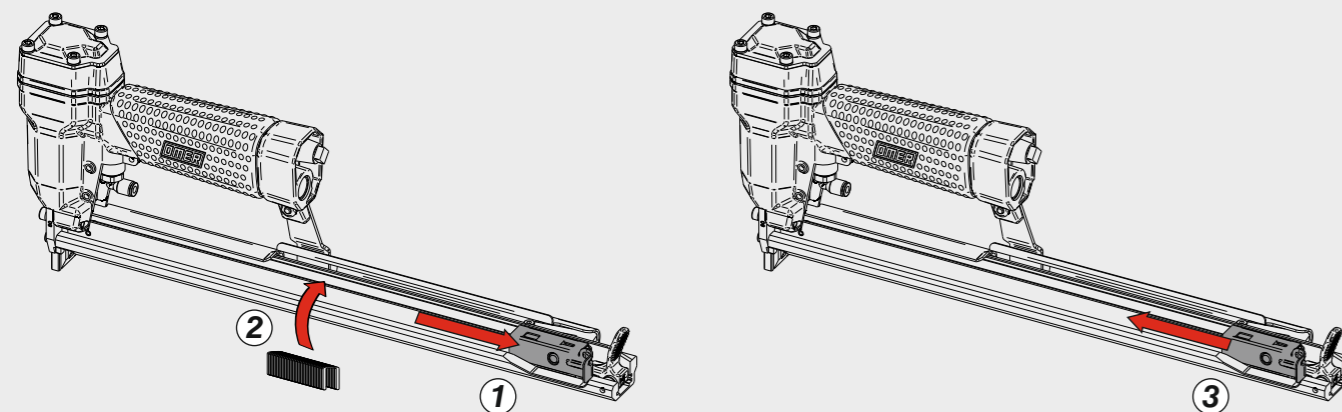

80.16 CLT-42

cod. 11560540-42

Dati tecnici Technical data Technische Daten Tekniska data	Caractéristiques techniques Datos técnicos Τεχνικά χαρακτηριστικά	Dados técnicos Technische gegevens Teknik veriler
--	---	---

Misure impiegabili Lengths Verwendbare Nagellänge Dimensioner som kan användas	Dimensions utiles Medidas de longitud Μήκος Αναλωσίμου	Medidas utilizáveis Toepasbare afmetingen Boy	4 ÷ 16
Capacità caricatore n° punti Magazine capacity Magazinkapazität Nägel Magasinkapacitet Antal punkter	Capacité chargeur n° de points Capacidad cargador n° puntos Δυνατότητα γεμιστέρα	Capacidade carregador n° pontos Capaciteit magazijn in aantal spijkers Dergi kapasitesi	285
Pressione d'esercizio Operating pressure Betriebsdruck Drifttryck	Pression d'exercice Presión de servicio Πίεση λειτουργίας	Pressão de serviço Werkdruk Çalışma basıncı	4 ÷ 6 bar 60 ÷ 90 psi
Consumo aria Air consumption Luftverbrauch Luftförbrukning	Consommation d'air Consumo aire Κατανάλωση αέρα	Consumo ar Luchtverbruik Hava tüketimi	0,13
Peso Weight Gewicht Vikt	Poids Peso Βάρος	Peso Gewicht Ağırlık	1,30

Tipo di punto
Type of fastener
Befestigungsmittel
Type de rivet
Tipo de punto
Τύπος αναλωσίμου
Tipo de agrafó
Type nietjes
Zimba ve çivi tipleri
Typ av stygn

80

0,65x0,95

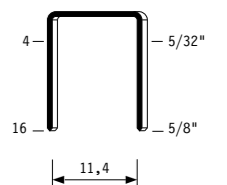

Crown: .500" (1/2")
Gauge: 21

Disincerramento - Jam clearing - Staubeseitigung - Décoincement - Desatascamiento - Απεμπλοκή
Desencravamento - Deblokkering bij vastlopen - Σίκισμα giderme - Rensning av igensättningar

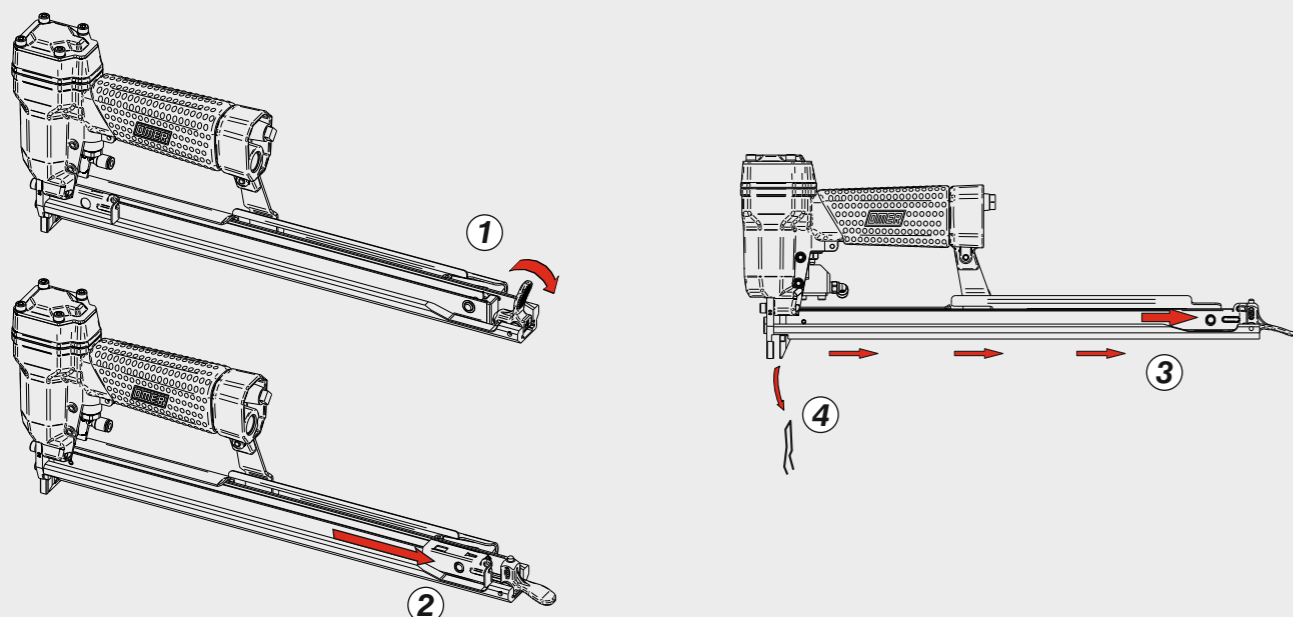

Dimensioni Dimensions Abmessungen Dimensioner (AxBxH)	Dimensions Dimensiones Διαστάσεις	Dimensões Afmetingen Boyutlar	378x43x180 (LxWxH)
---	---	-------------------------------------	------------------------------

EN 12549 :2009 EN ISO 3746 :2011 EN ISO 4871 :2009			
Potenza sonora emessa Sound power emitted Emittierte Schalleistung Avgiven ljudeffekt	Puissance sonore émise Potencia sonora emitida Εκπεμπόμενη ηχητική ισχύς	Potência sonora emitida Geëmitteerd geluidsvermogen Çıkan ses gücü (ses desibel)	87 dB(A) (K = 4 dB)

**DO NOT
HANDHELD
THIS TOOL**



11560540-42_8016CLT-42_5_rev20_03/03/2023 DV

Parti di ricambio - Spare parts - Ersatzteile - Pièces de rechange - Recambios
Ανταλλακτικά - Partes sobresselentes - Wisselstukken - Yedek parçalar - Reservdelar

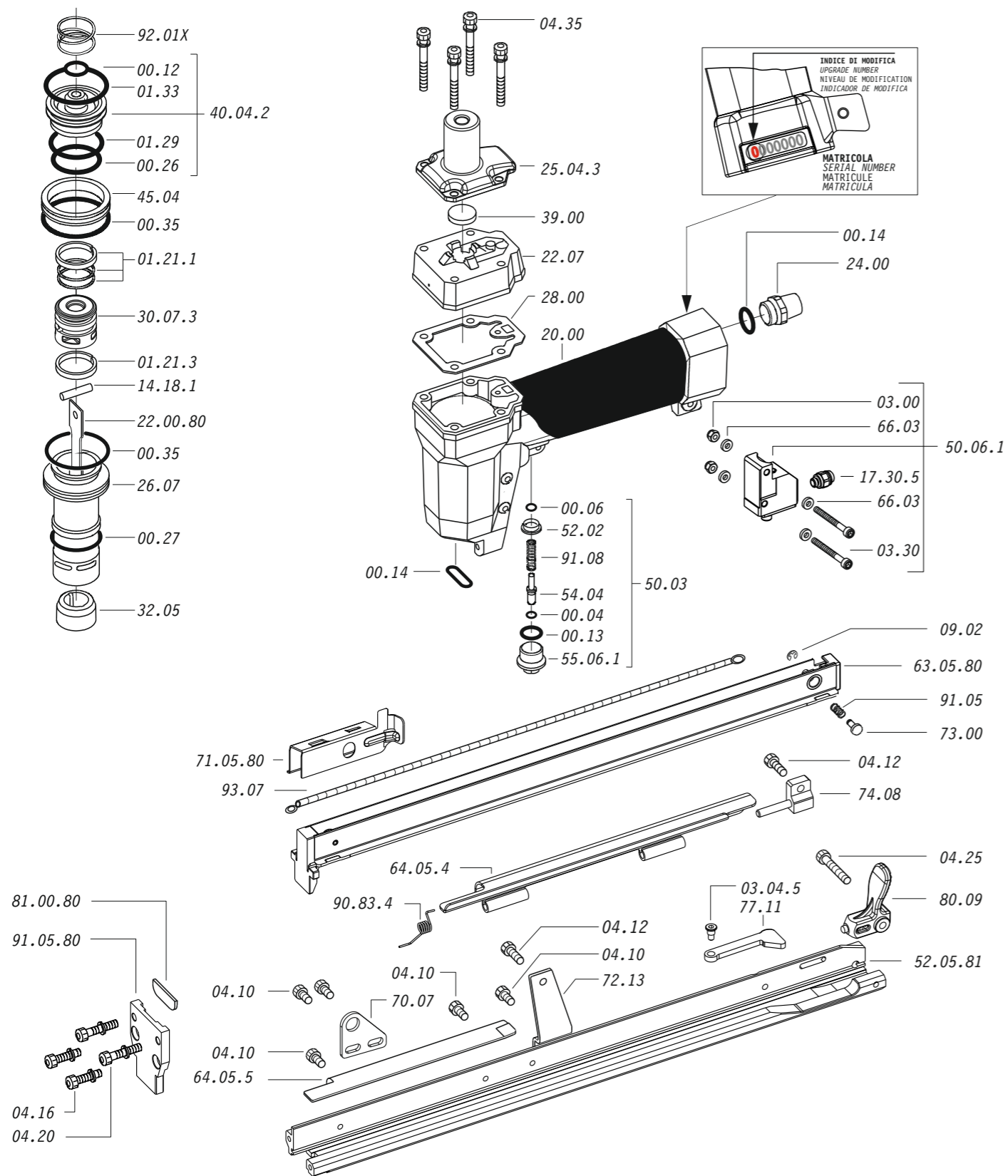

Dotazioni - Equipment - Ausstattung - Outillage - Dotaciones - Εξοπλισμός
Dotações - Uitrusting - Donanimlar - Utrustning

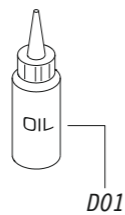

80.16 CLT-42

cod. 11560540-42

Parti di ricambio - Spare parts - Ersatzteile - Pièces de rechange - Recambios
Ανταλλακτικά - Partes sobresselentes - Wisselstukken - Yedek parçalar - Reservdelar

Cod.	Descrizione	Description
00.04	O-Ring	O-Ring
00.06	O-Ring	O-Ring
00.12	O-Ring	O-Ring
00.13	O-Ring	O-Ring
00.14	O-Ring	O-Ring
00.26	O-Ring	O-Ring
00.27	O-Ring	O-Ring
00.35	O-Ring	O-Ring
01.21.1	Guarnizione	Gasket
01.21.3	Guarnizione	Gasket
01.29	O-Ring	O-Ring
01.33	O-Ring	O-Ring
3.00	Dado	Nut
03.04.5	Vite	Screw
03.30	Vite	Screw
04.10	Vite	Screw
04.12	Vite	Screw
04.16	Vite	Screw
04.20	Vite	Screw
04.25	Vite	Screw
04.35	Vite	Screw
07.30	Chiave esagonale	Hex. bar wrench
09.02	Anello elastico	Elastic ring
14.18.1	Spina	Pin
17.30.5	Attacco	Connection
20.00	Corpo	Body
22.07	Testa	Head
24.00	Silenziatore	Silencer
25.04.3	Deflettore	Exhaust deflector
26.07	Cilindro	Cylinder
28.00	Guarnizione	Gasket
30.07.3	Pistone	Piston
32.05	Ammortizzatore	Bumper
39.00	Guarnizione scarico	Exhaust gasket
40.04.2	Valvola completa	Valve ass'y
45.04	Anello valvola	Ring
50.03	Pulsante completo	Trigger valve ass'y
50.06.1	Comando a distanza	Remote control trigger
52.02	Boccola	Bush
54.04	Pulsante	Trigger valve
55.06.1	Raccordo	Bush
64.05.4	Carter mobile	Hold down
64.05.5	Carter	Hold down
66.03	Rondella	Washer
70.07	Supporto	Support
72.13	Reggicaricatore	Support
73.00	Perno	Pin
74.08	Staffa	Support
77.11	Leva	Lever
80.09	Grilletto chiusura	Trigger
90.83.4	Molla	Spring
91.05	Molla	Spring
91.08	Molla	Spring
92.01X	Molla	Spring
93.07	Molla	Spring
22.00.80	Battente	Driver
52.05.81	Caricatore	Magazine
63.05.80	Carrello	Slider
71.05.80	Spingipunto	Pusher
81.00.80	Controtestina	Nose
91.05.80	Testina	Nose plate
D01	Bocchetta olio	Oiler

Guarnizioni - O-Rings - Dichtungen - Juntas - Anelli toriques - Vedantes - O-ringen - Contalar - O-ringar

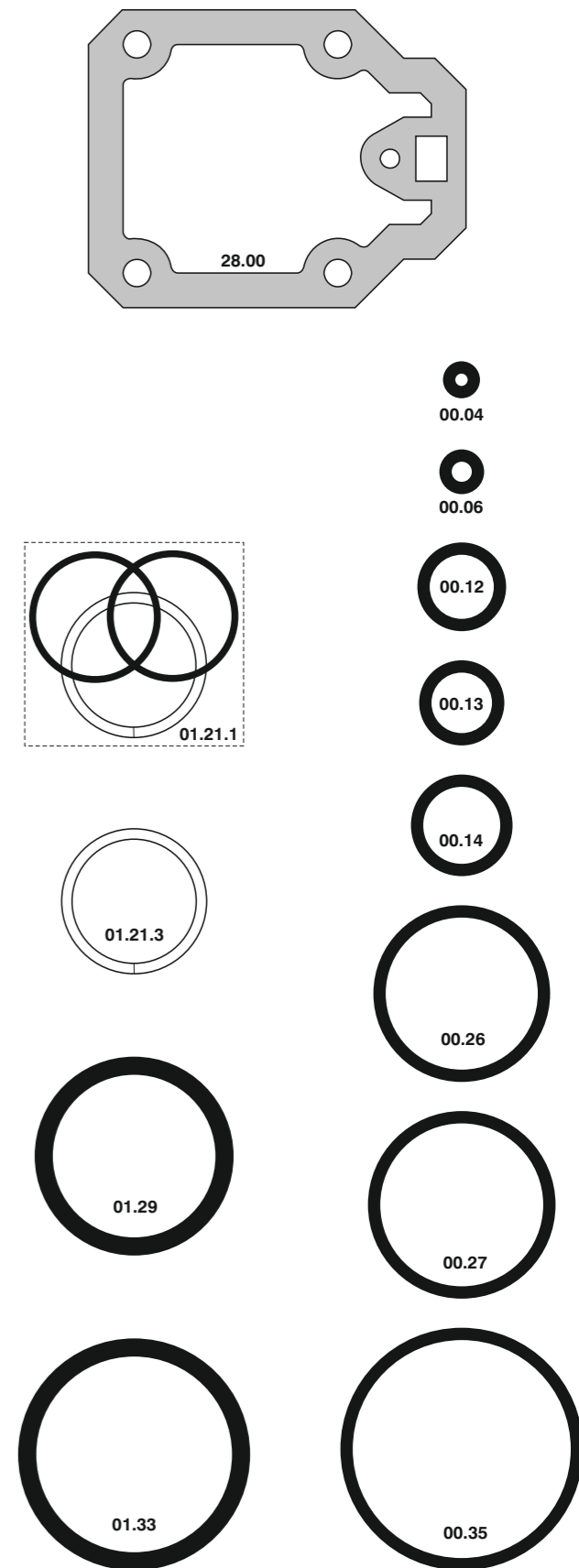

00.70.5

Indice di modifica
Upgrade number

5

80.16 CLT-42

cod. 11560540-42