

**Azionamento singolo con doppia attivazione**  
 Single actuation with dual activation

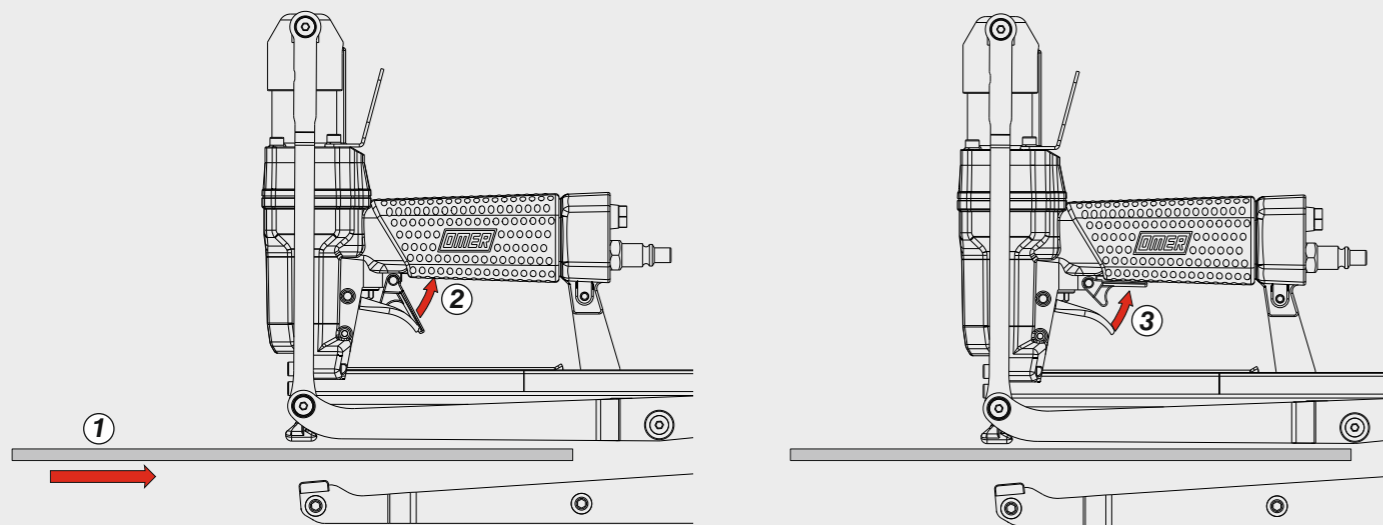

<b>Manuale d'uso, manutenzione e parti di ricambio</b>	<b>Parte 2</b>
<b>Manual for use, maintenance and spare parts</b>	<b>Part 2</b>
<b>Bedienungs- und Wartungshandbuch sowie Ersatzteilleiste</b>	<b>Teil 2</b>
<b>Mode d'emploi, de maintenance et pièces de rechange</b>	<b>Partie 2</b>
<b>Manual de uso, mantenimiento y recambios</b>	<b>Part 2</b>
<b>Εγχειρίδιο χρήσης, συντήρησης και ανταλλακτικών</b>	<b>Μέρος 2</b>
<b>Manual de uso, manutenção e peças sobresselentes</b>	<b>Parte 2</b>
<b>Handleiding voor gebruik, onderhoud en wisselstukken</b>	<b>Deel 2</b>
<b>Kullanım, bakım ve yedek parça kılavuzu</b>	<b>Kısım 2</b>
<b>Användar-, underhålls- och reservdelshandbok</b>	<b>Del 2</b>



**PL77K.16 LLJ**

cod. 11566K530L



**Caricamento - Loading - Laden - Chargement - Carga - Γέμισμα - Carregamento - Laden - Yükleme - Laddning**

**Caricamento da sopra**  
 Top load magazine

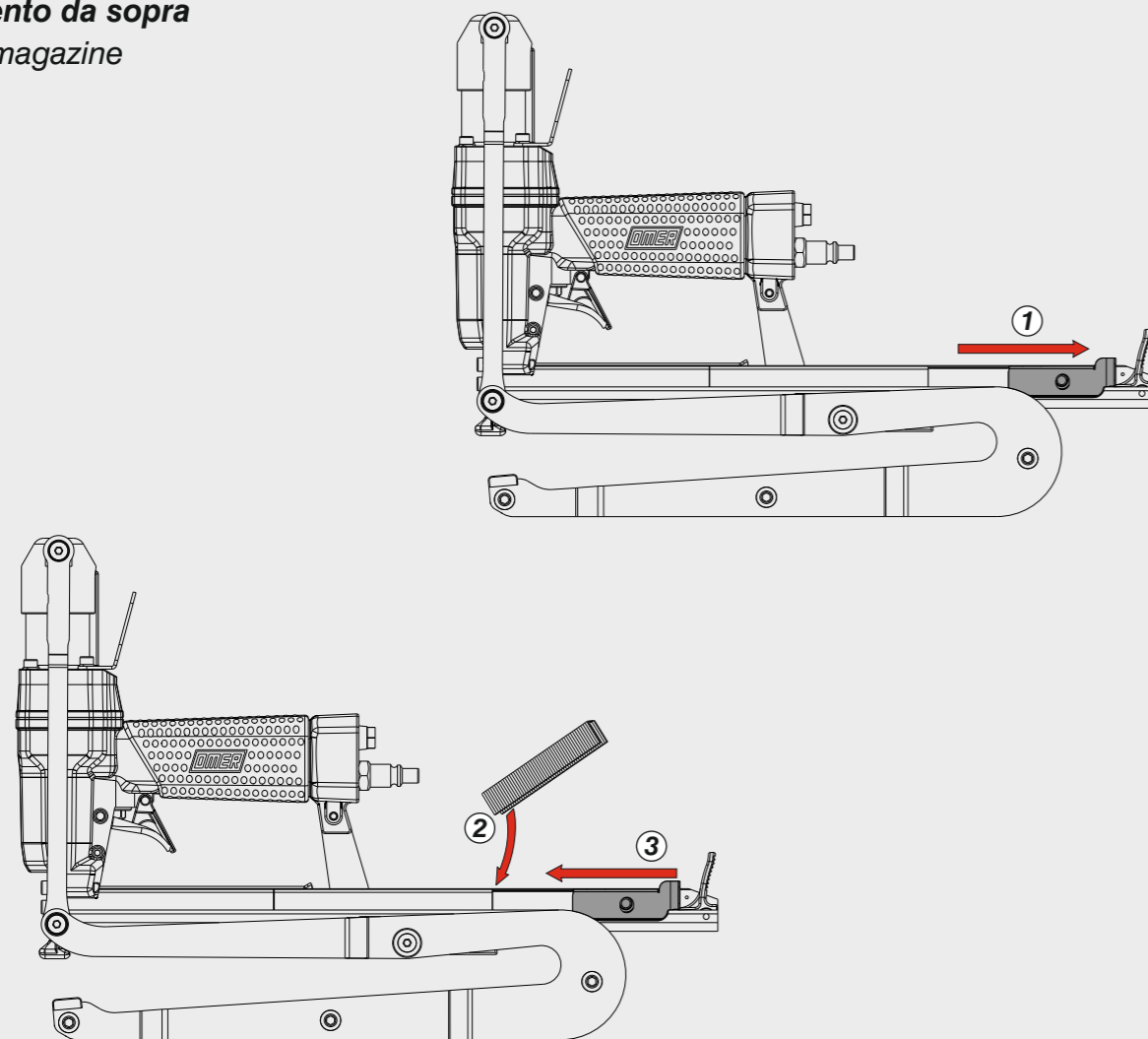

<b>Dati tecnici</b> Technical data Technische Daten Tekniska data	Caractéristiques techniques Datos técnicos Τεχνικά χαρακτηριστικά	Dados técnicos Technische gegevens Teknik veriler
--	---	---

<b>Misure impiegabili</b> Lengths Verwendbare Nagellänge Dimensioner som kan användas	Dimensions utiles Medidas de longitud Μήκος Αναλωσίμου	Medidas utilizáveis Toepasbare afmetingen Boy	<b>10 ÷ 16</b>
<b>Capacità caricatore n° punti</b> Magazine capacity Magazinkapazität Nägel Magasinkapacitet Antal punkter	Capacité chargeur n° de points Capacidad cargador n° puntos Δωνατοτητα γεμιστερα	Capacidade carregador n° pontos Capaciteit magazijn in aantal spijkers Dergi kapasitesi	<b>110</b>
<b>Pressione d'esercizio</b> Operating pressure Betriebsdruck Drifttryck	Pression d'exercice Presión de servicio Πίεση λειτουργίας	Pressão de serviço Werkdruk Çalışma basıncı	<b>4,5 ÷ 6,5 bar</b> <b>65 ÷ 95 psi</b>
<b>Consumo aria</b> Air consumption Luftverbrauch Luftförbrukning	Consommation d'air Consumo aire Κατανάλωση αέρα	Consumo ar Luchtverbruik Hava tüketimi	<b>0,20</b>
<b>Peso</b> Weight Gewicht Vikt	Poids Peso Βάρος	Peso Gewicht Ağırlık	<b>2,40</b>
<b>Dimensioni</b> Dimensions Abmessungen Dimensioner (AxBxH)	Dimensions Dimensiones Διαστάσεις	Dimensões Afmetingen Boyutlar	<b>362x63x260</b> (LxWxH)

**Stapling results**

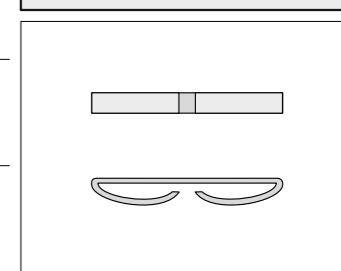

**Tipo di punto**  
 Type of fastener  
 Befestigungsmittel  
 Type de rivet  
 Tipo de punto  
 Τύπος αναλωσίμου  
 Tipo de agrafo  
 Type nietjes  
 Zimba ve çivi tipleri  
 Typ av stygn

**77K**

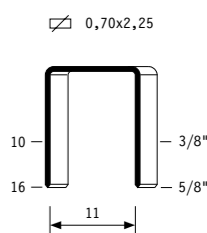

Crown: .488" (1/2")  
 Gauge: 17

<b>EN 12549 :2009 EN ISO 4871 :2009</b>	<b>Pressione sonora in pos. operatore</b> Sound pressure in operator's position Schalldruck am Arbeitsplatz Ljudtryck på operatörsplatsen	Pression sonore poste Opérateur Presión sonora en la pos. del operador Ηχητική πίεση στη θέση του χειριστή Operatör pozisyonunda ses basıncı	<b>88 dB(A)</b> (K= 4 dB)
<b>EN 12549 :2009 EN ISO 3746 :2011 EN ISO 4871 :2009</b>	<b>Potenza sonora emessa</b> Sound power emitted Emitierte Schalleistung Avgiven ljudeffekt	Puissance sonore émise Potencia sonora emitida Εκπεμπόμενη ηχητική ισχύς	<b>95 dB(A)</b> (K= 4 dB)
<b>CEN ISO/TS 8662-11 :2006 EN ISO 5349-2 :2004 EN 12096 :1999</b>	<b>Emissione vibratoria sull'impugnatura</b> Vibratory emissions on handle Vibrationsemission am Griff Vibrationsemission på handtaget	Émission vibratoire sur la prise en main Emisión de vibraciones en la empuñadura Εκπεμπόμενες δονήσεις στη λαβή Tutamak üzerindeki vibrasyon emisyonları	<b>3,15 m/s<sup>2</sup></b> (K= 2 m/s <sup>2</sup> )

11566K530L\_PL77K16LLJ\_5\_rev21\_03/03/2023 DV

Parti di ricambio - Spare parts - Ersatzteile - Pièces de rechange - Recambios  
Ανταλλακτικά - Partes sobresselentes - Wisselstukken - Yedek parçalar - Reservdelar

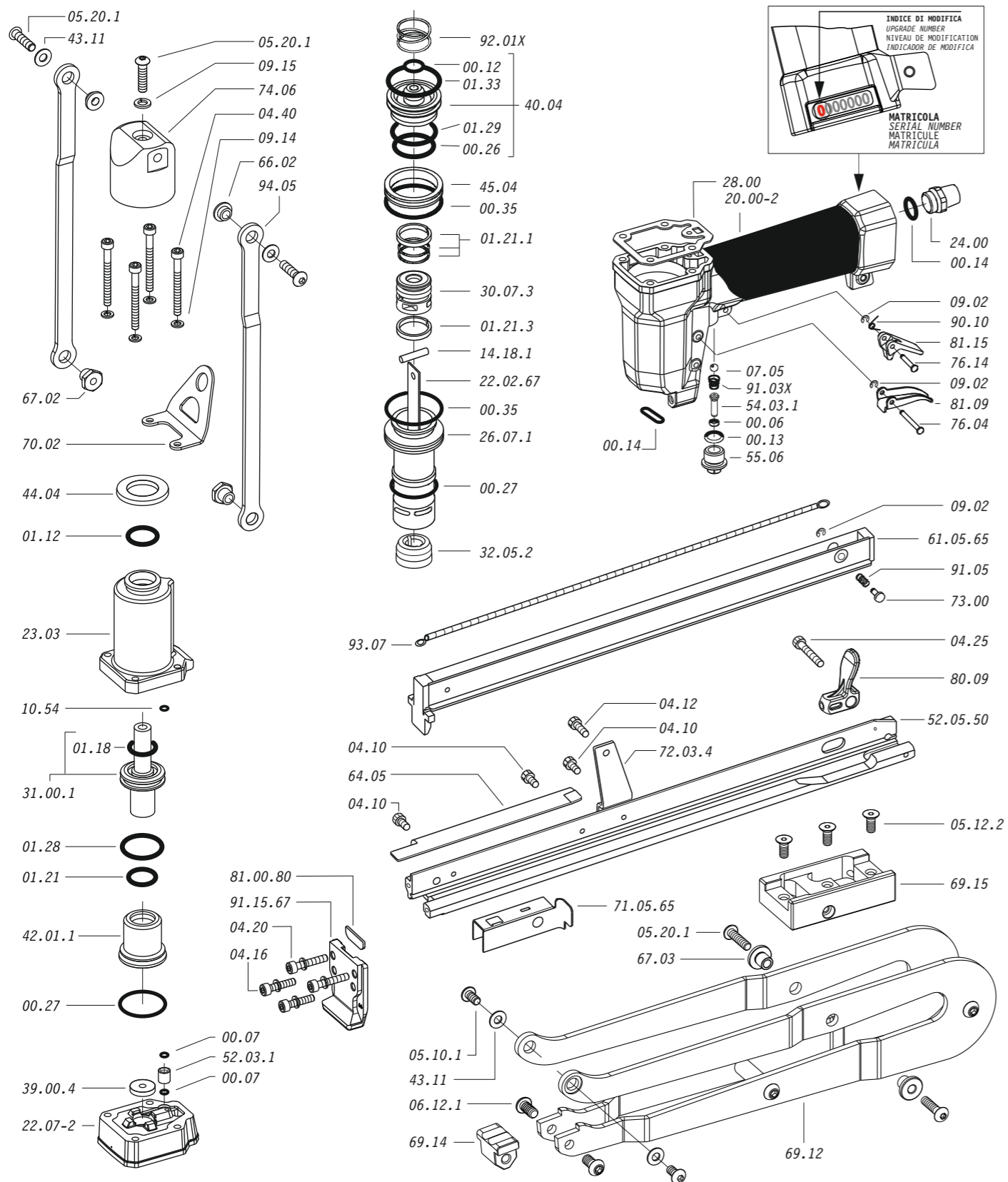

Dotazioni - Equipment - Ausstattung - Outillage - Dotaciones - Εξοπλισμός  
Dotações - Uitrusting - Donanımlar - Utrustning

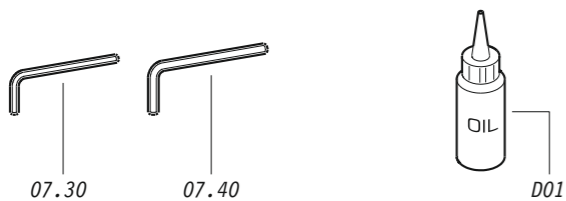

**PL77K.16 LLJ**

cod. 11566K530L

Parti di ricambio - Spare parts - Ersatzteile - Pièces de rechange - Recambios  
Ανταλλακτικά - Partes sobresselentes - Wisselstukken - Yedek parçalar - Reservdelar

Cod.	Descrizione	Description
00.06	O-Ring	O-Ring
00.07	O-Ring	O-Ring
00.12	O-Ring	O-Ring
00.13	O-Ring	O-Ring
00.14	O-Ring	O-Ring
00.26	O-Ring	O-Ring
00.27	O-Ring	O-Ring
00.35	O-Ring	O-Ring
01.12	O-Ring	O-Ring
01.18	O-Ring	O-Ring
01.21	O-Ring	O-Ring
01.21.1	Guarnizione	Gasket
01.21.3	Guarnizione	Gasket
01.28	O-Ring	O-Ring
01.29	O-Ring	O-Ring
01.33	O-Ring	O-Ring
04.10	Vite	Screw
04.12	Vite	Screw
04.16	Vite	Screw
04.20	Vite	Screw
04.25	Vite	Screw
04.40	Vite	Screw
05.10.1	Vite	Screw
05.12.2	Vite	Screw
05.20.1	Vite	Screw
06.12.1	Vite	Screw
07.05	Sfera	Ball
07.30	Chiave esagonale	Hex. bar wrench
07.40	Chiave esagonale	Hex. bar wrench
09.02	Anello elastico	Elastic ring
09.14	Rondella	Washer
09.15	Rondella	Washer
10.54	O-Ring	O-Ring
14.18.1	Spina	Pin
20.00-2	Corpo	Body
22.07-2	Testa	Head
23.03	Testa superiore	Head
24.00	Silenziatore	Silencer
26.07.1	Cilindro	Cylinder
28.00	Guarnizione	Gasket
30.07.3	Pistone	Piston
31.00.1	Pistone ganascia	Jaws Piston
32.05.2	Ammortizzatore	Bumper
39.00.4	Guarnizione scarico	Exhaust gasket
40.04	Valvola completa	Valve ass'y
42.01.1	Anello superiore	Upper ring
43.11	Rondella	Washer
44.04	Ammortizzatore	Bumper
45.04	Anello valvola	Ring
52.03.1	Distanziale	Pacer
54.03.1	Pulsante	Trigger valve
55.06	Raccordo	Bush
66.02	Boccola	Bush
64.05	Carter	Hold down
67.02	Boccola	Bush
67.03	Boccola	Bush
69.12	Ganascia	Jaws
69.14	Ribattitore	Riveter
69.15	Supporto	Support
70.02	Supporto	Support
72.03.4	Reggicaricatore	Support
73.00	Perno	Pin
74.06	Staffa	Bracket
76.04	Perno	Pin
76.14	Perno	Pin
80.09	Grilletto chiusura	Trigger
81.09	Grilletto comando	Trigger
81.15	Controgrilletto	Safety
90.07	Molla	Spring
90.10	Molla	Spring
91.03X	Molla	Spring
91.05	Molla	Spring
92.01X	Molla	Spring
93.07	Molla	Spring
94.05	Tirante	Connecting rod
22.02.67	Battente	Driver
52.05.50	Caricatore	Magazine
61.05.65	Carrello	Slider
71.05.65	Spingipunto	Pusher
81.00.80	Controtestina	Nose
91.15.67	Testina	Nose plate
D01	Bocchetta olio	Oiler

Guarnizioni - O-Rings - Joints toriques - Juntas - Δακτύλιος στεγανοποίησης - Vedantes - O-ringen - Contalar - O-ringar

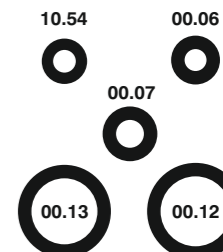
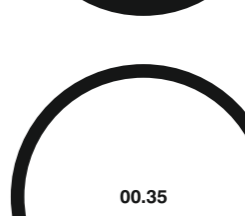
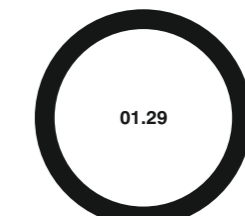
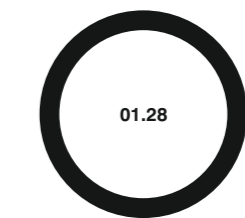
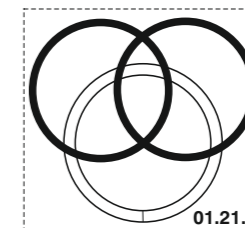
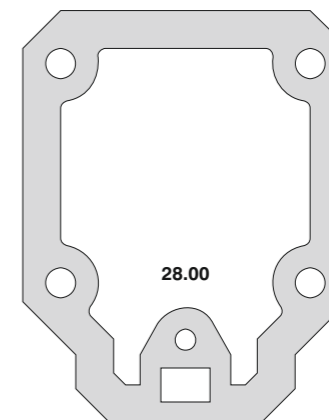

**00.70.8**

**PL77K.16 LLJ**

cod. 11566K530L

Indice di modifica  
Upgrade number

**5**

Disincceppamento - Jam clearing - Staubeseitigung - Décoincement - Desatascamiento - Απεμπλοκή  
Desencravamento - Deblokkering bij vastlopen - Sikişma giderme - Rensning av igensättningar

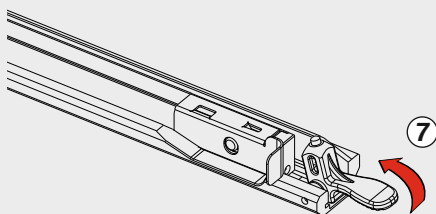
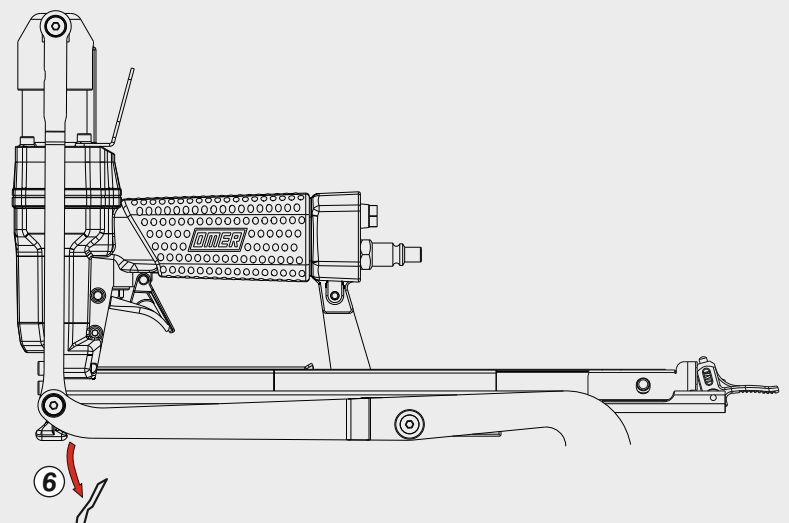
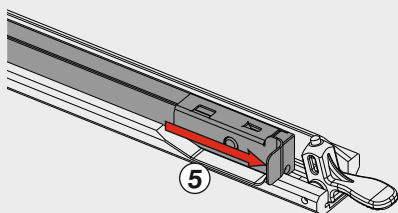
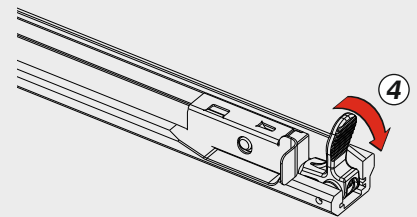
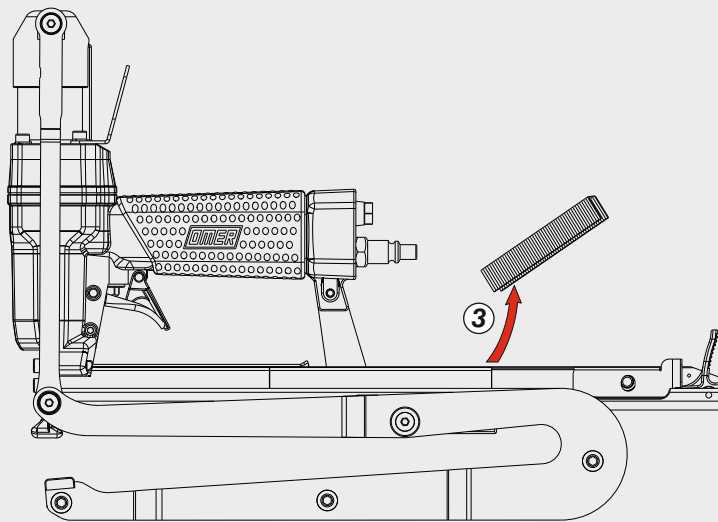
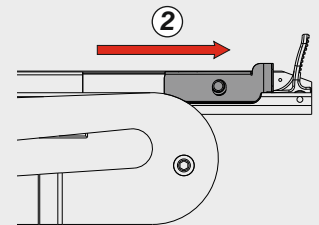
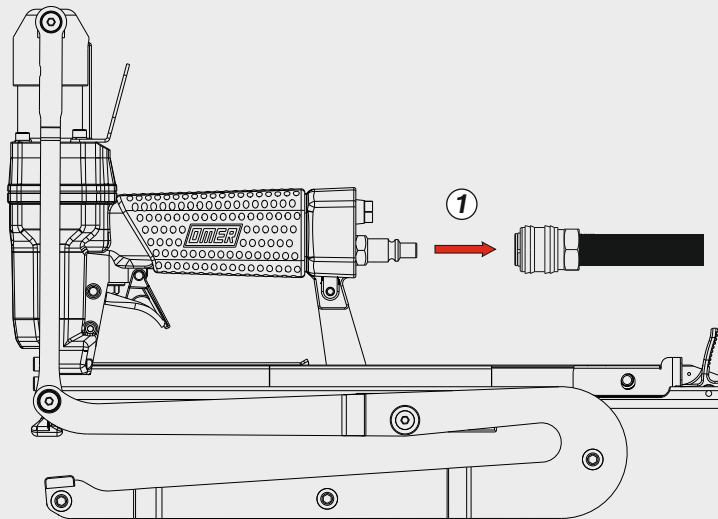

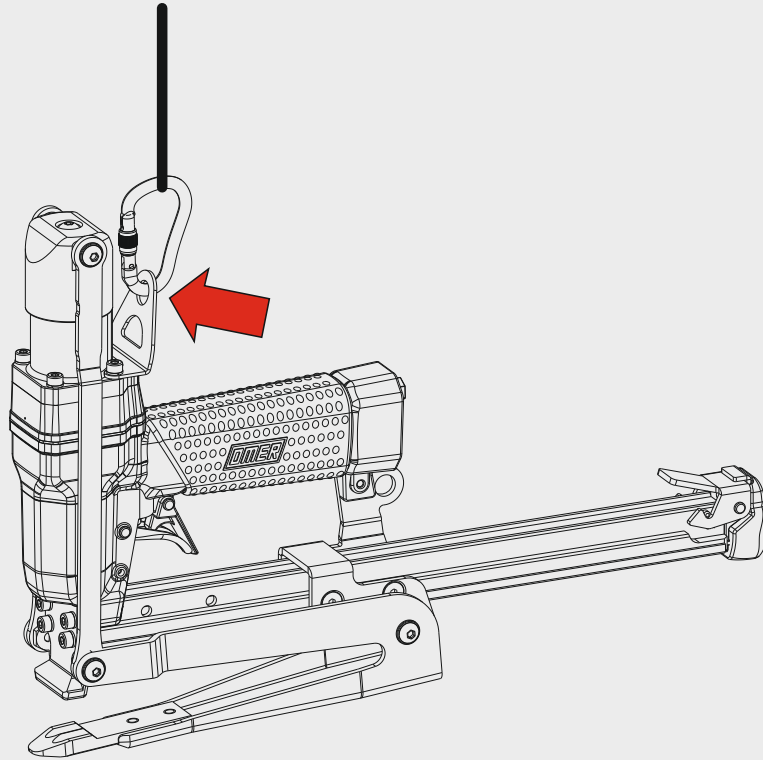

**Spessore**  
*Thickness*

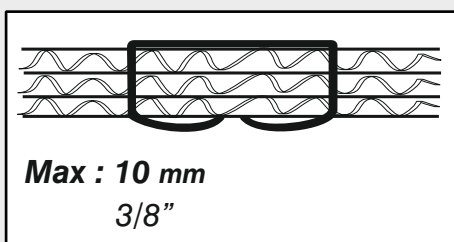
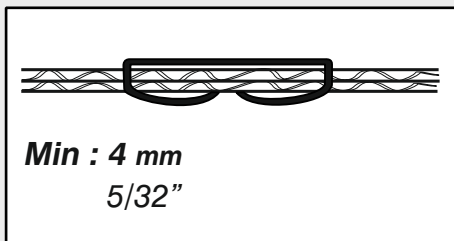

**Dimensioni Ganascia**  
*Jaw Dimension*

