

Caricamento da sotto
Bottom load magazine

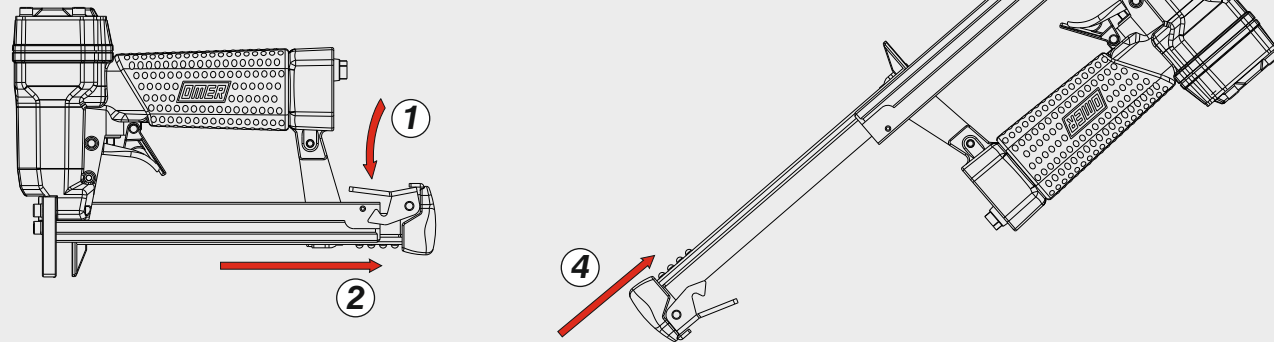

Caricamento dischi - Disk loading

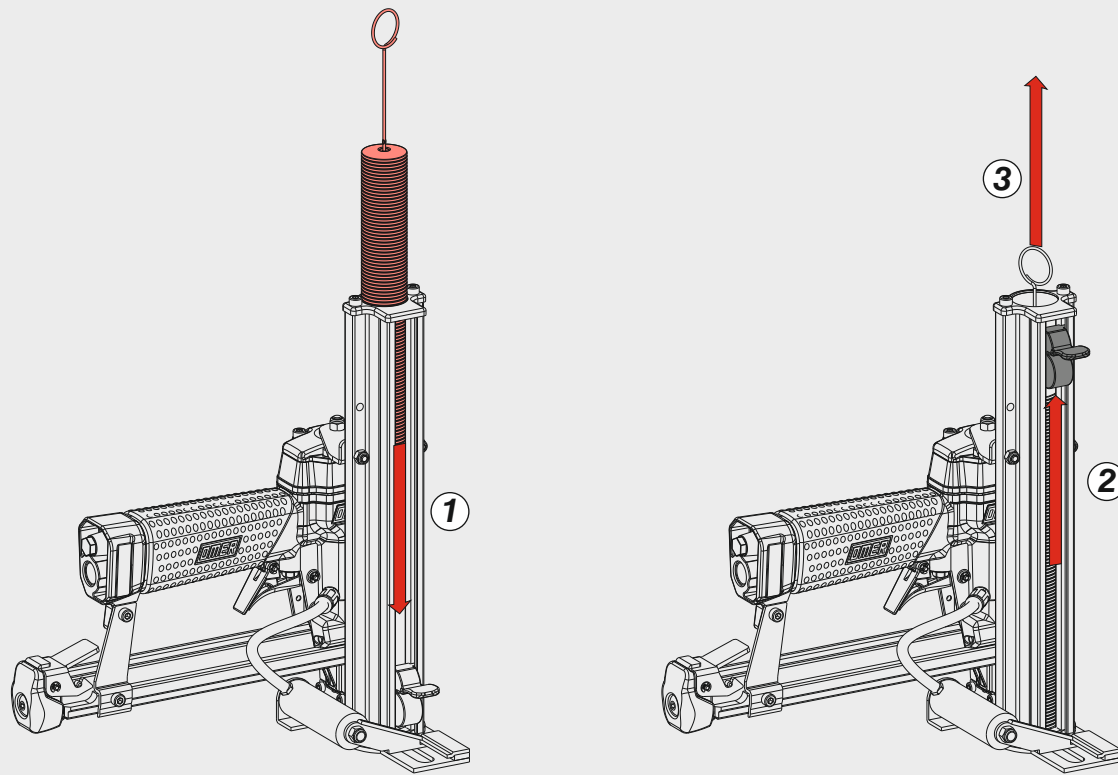

Disincceppamento - Jam clearing - Staubeseitigung - Décoincement - Desatascamiento - Απεμπλοκή
Desencravamento - Deblokkering bij vastlopen - Sıkışma giderme - Rensning av igensättningar

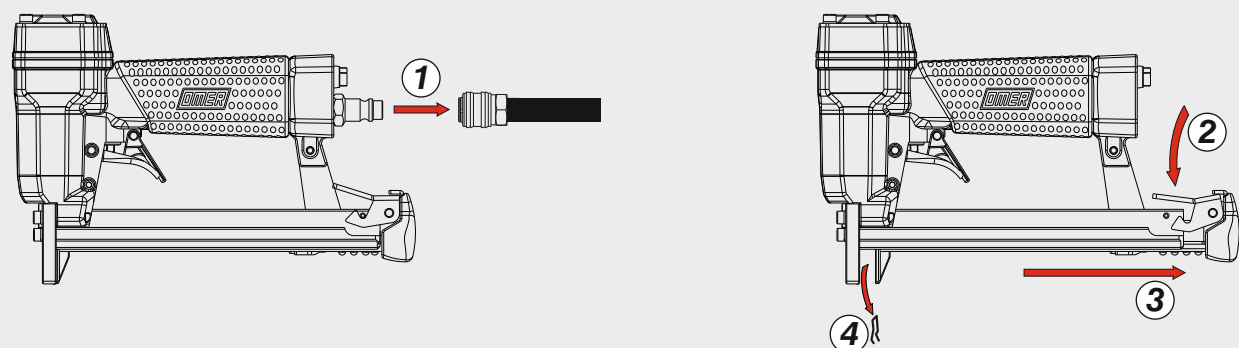

Manuale d'uso, manutenzione e parti di ricambio	Parte 2
Manual for use, maintenance and spare parts	Part 2
Bedienungs- und Wartungshandbuch sowie Ersatzteilliste	Teil 2
Mode d'emploi, de maintenance et pièces de rechange	Partie 2
Manual de uso, mantenimiento y recambios	Part 2
Εγχειρίδιο χρήσης, συντήρησης και ανταλλακτικών	Μέρος 2
Manual de uso, manutenção e peças sobresselentes	Parte 2
Handleiding voor gebruik, onderhoud en wisselstukken	Deel 2
Kullanım, bakım ve yedek parça kılavuzu	Kısım 2
Användar-, underhålls- och reservdelshandbok	Del 2



92.16 DK

cod. 1157200DK



Dati tecnici Technical data Technische Daten Tekniska data	Caractéristiques techniques Datos técnicos Τεχνικά χαρακτηριστικά	Dados técnicos Technische gegevens Teknik veriler
--	---	---

Misure impiegabili Lengths Verwendbare Nagellänge Dimensioner som kan användas	Dimensions utiles Medidas de longitud Μήκος Αναλωσίμου	Medidas utilizáveis Toepasbare afmetingen Boy	10 ÷ 15
Capacità caricatore n° punti Magazine capacity Magazinkapazität: Nägel Magasinkapacitet: Antal punkter	Capacité chargeur n° de points Capacidad cargador n° puntos Δυνατότητα γεμιστερα	Capacidade carregador n° pontos Capaciteit magazijn in aantal spijkers Dergi kapasitesi	100 & (100 disk)
Pressione d'esercizio Operating pressure Betriebsdruck Drifttryck	Pression d'exercice Presión de servicio Πίεση λειτουργίας	Pressão de serviço Werkdruk Çalışma basıncı	5 ÷ 6,5 bar 70 ÷ 95 psi
Consumo aria Air consumption Luftverbrauch Luftförbrukning	Consommation d'air Consumo aire Κατανάλωση αέρα	Consumo ar Luchtverbruik Hava tüketimi	0,18
Peso Weight Gewicht Vikt	Poids Peso Βάρος	Peso Gewicht Ağırlık	1,60
Dimensioni Abmessungen Dimensioner (AxBxH)	Dimensions Διαστάσεις	Dimensões Afmetingen Boyutlar	223x128x265 (LxWxH)

EN 12549 :2009 EN ISO 4871 :2009	Pressione sonora in pos. operatore Sound pressure in operator's position Schalldruck am Arbeitsplatz Ljudtryck på operatörsplatsen	Pression sonore poste Opérateur Presión sonora en la pos. del operador Ηχητική πίεση στη θέση του χειριστή Operatör pozisyonunda ses basıncı	81 dB(A) (K= 4 dB)
---	---	---	------------------------------

EN 12549 :2009 EN ISO 3746 :2011 EN ISO 4871 :2009	Potenza sonora emessa Sound power emitted Emitierte Schalleistung Avgiven ljudeffekt	Puissance sonore émise Potencia sonora emitida Εκπεμπόμενη ηχητική ισχύς	Potência sonora emitida Geëmitteerd geluidsvermogen Çıkan ses gücü (ses desibeli)	88 dB(A) (K= 4 dB)
---	--	--	---	------------------------------

CEN ISO/TS 8662-11 :2006 EN ISO 5349-2 :2004 EN 12096 :1999	Emissione vibratoria sull'impugnatura Vibratory emissions on handle Vibrationsemission am Griff Vibrationsemission på handtaget	Émission vibratoire sur la prise en main Emisión de vibraciones en la empuñadura Εκπεμπόμενες δονήσεις στη λαβή	Emissão vibratória na empunhadura Trillingsemissie op de handgreep Tutamak üzerinde vibrasyon emisyonları	<2,5 m/s² (K= 2 m/s²)
--	---	---	---	------------------------------------

Tipo di punto
Type of fastener
Befestigungsmittel
Type de rivet
Tipo de punto
Τύπος αναλωσίμου
Tipo de agrafó
Type nietjes
Zimba ve çivi tipleri
Typ av stygn

92

1,00x1,25

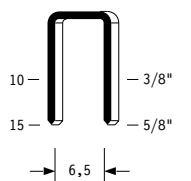

Crown: .334" (5/16")
Gauge: 18

DK25

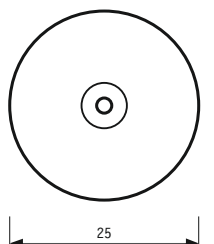

1157200DK_9216DK_5_rev21_06/03/2023 DV

Parti di ricambio - Spare parts - Ersatzteile - Pièces de rechange - Recambios
Ανταλλακτικά - Partes sobresselentes - Wisselstukken - Yedek parçalar - Reservdelar

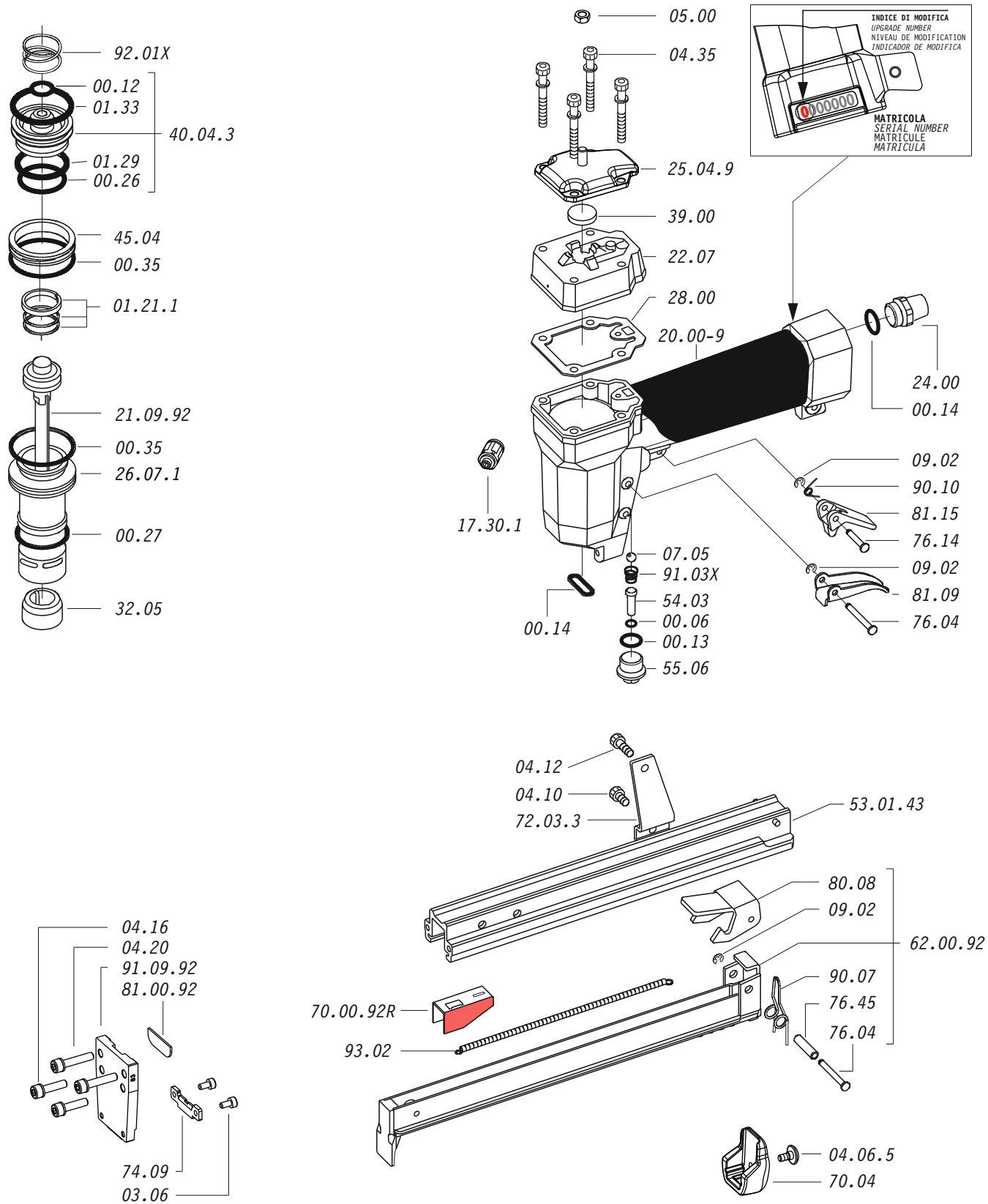

Dotazioni - Equipment - Ausstattung - Outillage - Dotaciones - Εξοπλισμός
Dotações - Uitrusting - Donanımlar - Utrustning

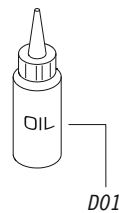
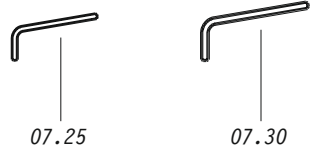

92.16 DK

cod. 1157200DK

Parti di ricambio - Spare parts - Ersatzteile - Pièces de rechange - Recambios
Ανταλλακτικά - Partes sobresselentes - Wisselstukken - Yedek parçalar - Reservdelar

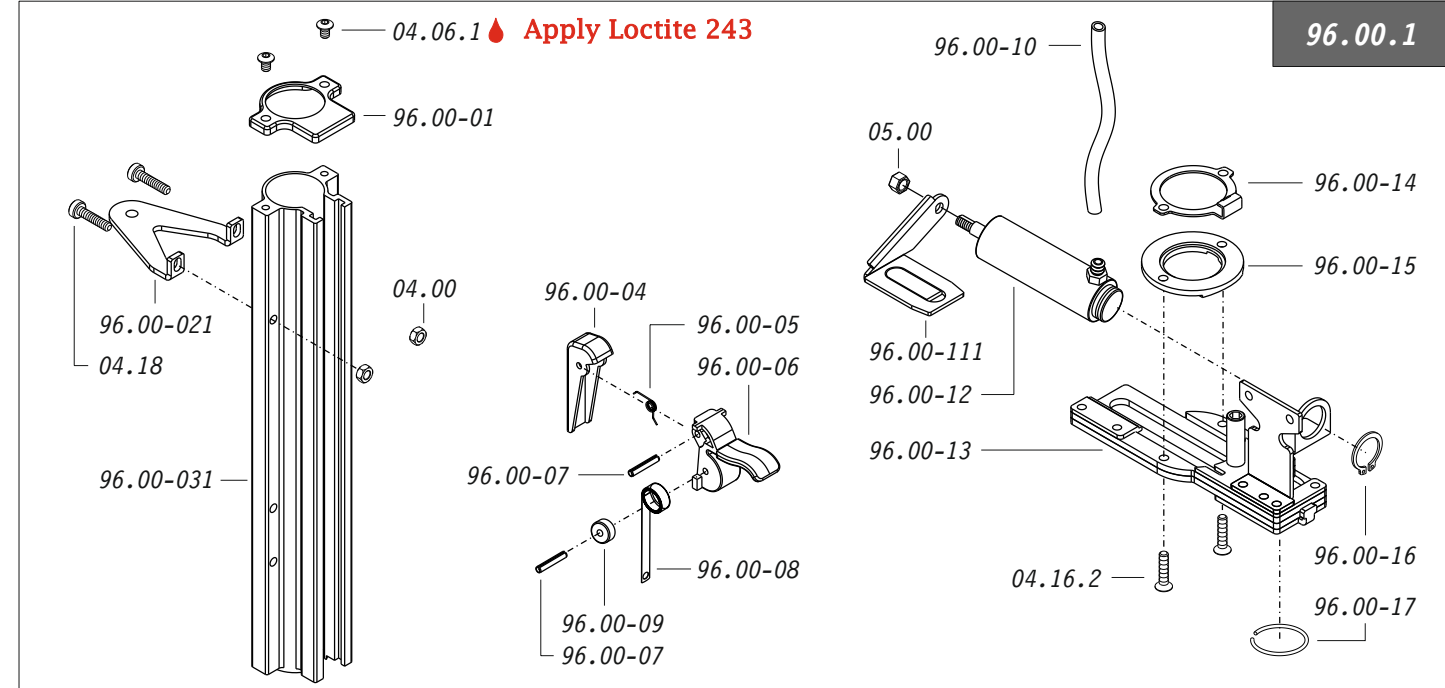

Cod.	Descrizione	Description	Cod.	Descrizione	Description	Cod.	Descrizione	Description
00.06	O-Ring	O-Ring	20.00-9	Corpo	Body	96.00.1	Kit caricatore disc.	Magazine disk Kit
00.12	O-Ring	O-Ring	22.07	Testa	Head	96.00-01	Tappo	Cap
00.13	O-Ring	O-Ring	24.00	Silenziatore	Silencer	96.00-021	Supporto	Support
00.14	O-Ring	O-Ring	25.04.9	Deflettore	Exhaust deflector	96.00-031	Caricatore dischi	Disk magazine
00.26	O-Ring	O-Ring	26.07.1	Cilindro	Cylinder	96.00-04	Spingidisco	Pusher
00.27	O-Ring	O-Ring	28.00	Guarnizione	Gasket	96.00-05	Molla	Spring
00.35	O-Ring	O-Ring	32.05	Ammortizzatore	Bumper	96.00-06	Leva	Latch
01.21.1	Guarnizione	Gasket	39.00	Guarnizione scarico	Exhaust gasket	96.00-07	Perno	Pin
01.29	O-Ring	O-Ring	40.04.3	Valvola completa	Valve ass'y	96.00-08	Molla	Spring
01.33	O-Ring	O-Ring	45.04	Anello valvola	Ring	96.00-09	Rullo molla	Roller
03.06	Vite	Screw	54.03	Pulsante	Trigger valve	96.00-10	Tubo	Tube
04.00	Dado	Nut	55.06	Raccordo	Bush	96.00-111	Alimentatore dischi	Disk feeder
04.06.1	Vite	Screw	70.02.9K	Supporto bilanciare	Tool hangers	96.00-12	Pistone	Piston
04.06.5	Vite	Screw	70.04	Protezione	Guard	96.00-13	Piastra	Plate
04.10	Vite	Screw	72.03.3	Reggicaricatore	Support	96.00-14	Anello	Ring
04.12	Vite	Screw	74.09	Piastrina	Plate	96.00-15	Anello	Ring
04.16	Vite	Screw	76.04	Perno	Pin	96.00-16	Anello elastico	Elastic ring
04.16.2	Vite	Screw	76.14	Perno	Pin	96.00-17	Anello	Ring
04.18	Vite	Screw	76.45	Perno molla	Pin	21.09.92	Battente	Driver
04.20	Vite	Screw	80.08	Grilletto chiusura	Trigger	53.01.43	Caricatore	Magazine
04.35	Vite	Screw	81.09	Grilletto comando	Trigger	62.00.92	Carrello	Slider
05.00	Dado	Nut	81.15	Controgrilletto	Safety	70.00.92R	Spingipunto	Pusher
07.05	Sfera	Ball	90.07	Molla	Spring	81.00.92	Controtestina	Nose
07.25	Chiave esagonale	Hex. bar wrench	90.10	Molla	Spring	91.09.92	Testina	Nose plate
07.30	Chiave esagonale	Hex. bar wrench	91.03X	Molla	Spring	D01	Bocchetta olio	Oiler
09.02	Anello elastico	Elastic ring	92.01X	Molla	Spring			
17.30.1	Attacco	Connection	93.02	Molla	Spring			

Guarnizioni - O-Rings - Dichtungen - Joints toriques - Juntas
Δακτύλιος στεγανοποίησης - Vedantes - O-ringen - Contalar - O-ringar

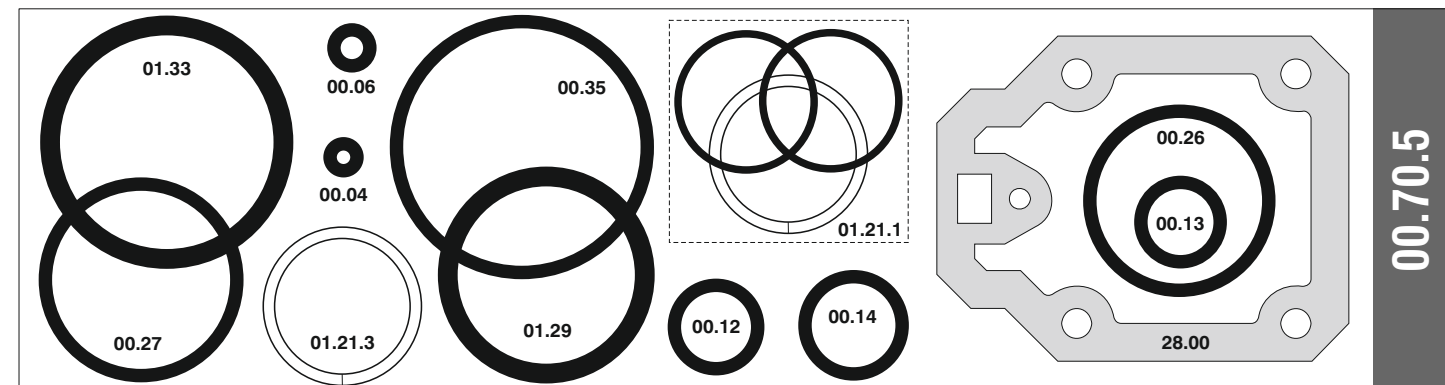

92.16 DK

cod. 1157200DK

Indice di modifica
Upgrade number

5

00.70.5

Azionamento singolo con doppia attivazione

Single actuation with dual activation

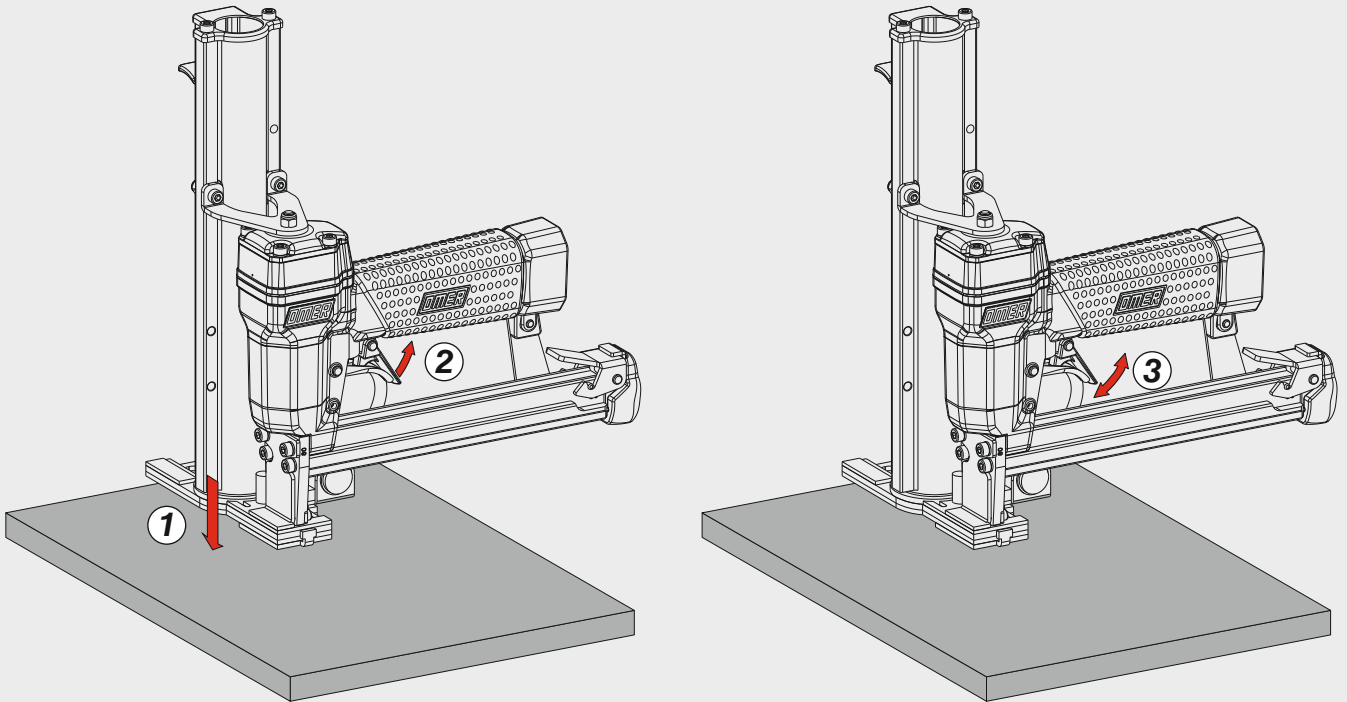

Supporto bilanciante - Tool hangers

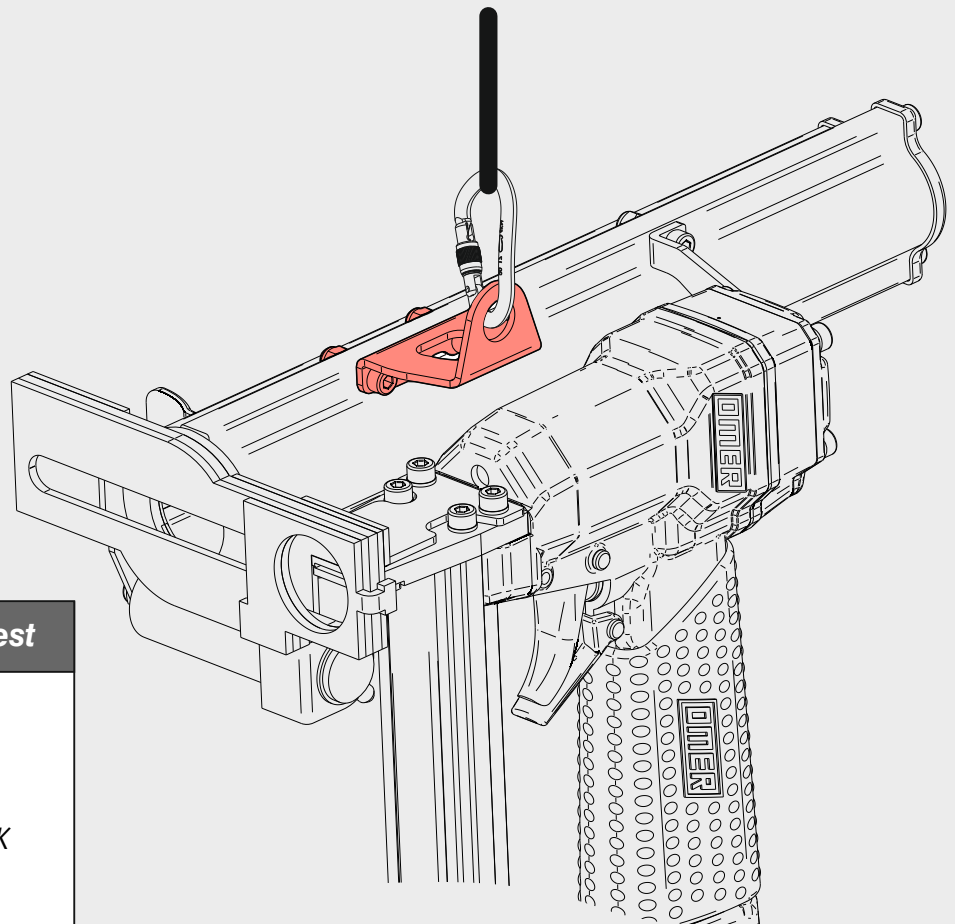

A richiesta - On request

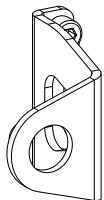

70.02.9K