

Caricamento da sotto
Bottom load magazine

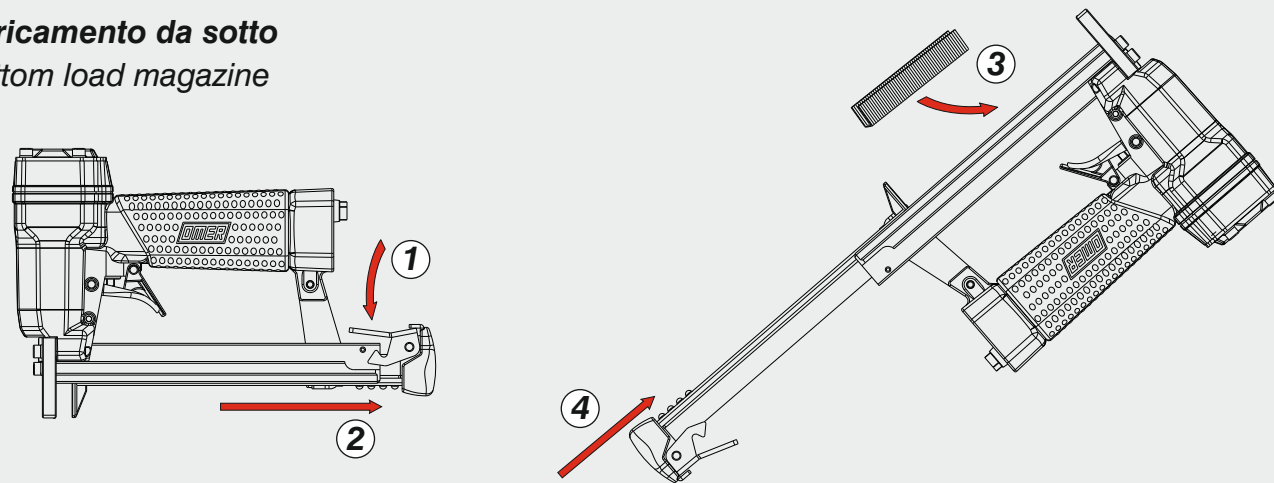

Caricamento dischi - Disk loading

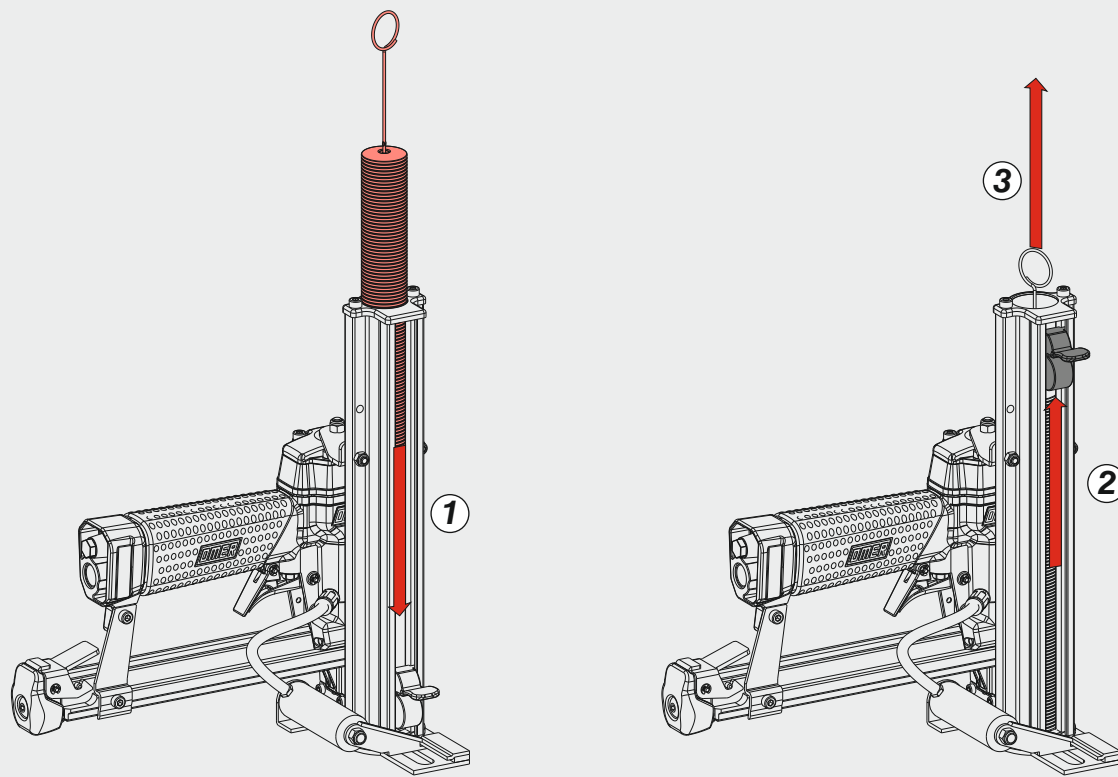

Disinzeppamento - Jam clearing - Staubeseitigung - Décoincement - Desatascamiento - Απεμπλοκή
Desencravamento - Deblokkering bij vastlopen - Sıkışma giderme - Rensning av igensättningar

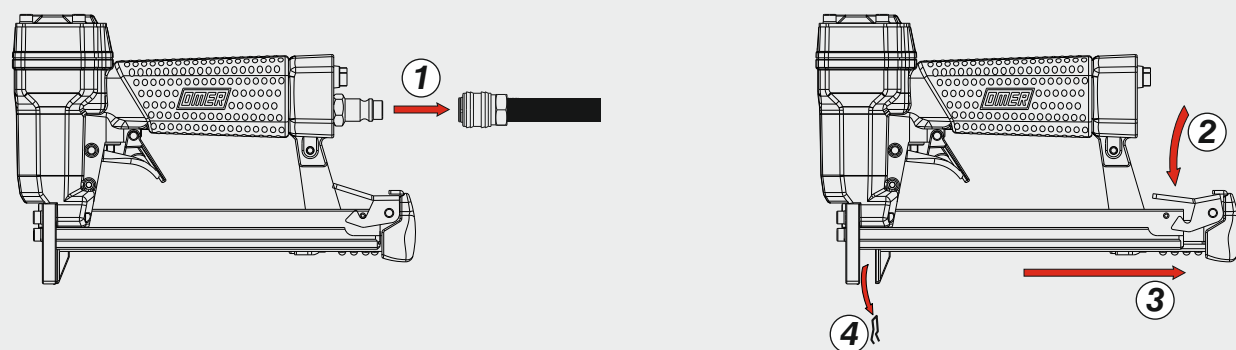

Manuale d'uso, manutenzione e parti di ricambio	Parte 2
Manual for use, maintenance and spare parts	Part 2
Bedienungs- und Wartungshandbuch sowie Ersatzteilliste	Teil 2
Mode d'emploi, de maintenance et pièces de rechange	Partie 2
Manual de uso, mantenimiento y recambios	Part 2
Εγχειρίδιο χρήσης, συντήρησης και ανταλλακτικών	Μέρος 2
Manual de uso, manutenção e peças sobresselentes	Parte 2
Handleiding voor gebruik, onderhoud en wisselstukken	Deel 2
Kullanım, bakım ve yedek parça kılavuzu	Kısım 2
Användar-, underhålls- och reservdelshandbok	Del 2



94.14 DK

cod. 1157400DK



Dati tecnici Technical data Technische Daten Tekniska data	Caractéristiques techniques Datos técnicos Τεχνικά χαρακτηριστικά	Dados técnicos Technische gegevens Teknik veriler
--	--	--

Misure impiegabili Lengths Verwendbare Nagellänge Dimensioner som kan användas	Dimensions utiles Medidas de longitud Μήκος Αναλωσίμου	Medidas utilizáveis Toepasbare afmetingen Boy	10 ÷ 15
Capacità caricatore n° punti Magazine capacity Magazinkapazität: Nägel Magasinkapacitet: Antal punkter	Capacité chargeur n° de points Capacidad cargador n° puntos Δυνατότητα γεμιστερα	Capacidade carregador n° pontos Capaciteit magazijn in aantal spijkers Dergi kapasitesi	100 & (100 disk)
Pressione d'esercizio Operating pressure Betriebsdruck Drifttryck	Pression d'exercice Presión de servicio Πίεση λειτουργίας	Pressão de serviço Werkdruk Çalışma basıncı	5 ÷ 6,5 bar 70 ÷ 95 psi
Consumo aria Air consumption Luftverbrauch Luftförbrukning	Consommation d'air Consumo aire Κατανάλωση αέρα	Consumo ar Luchtverbruik Hava tüketimi	0,18
Peso Weight Gewicht Vikt	Poids Peso Βάρος	Peso Gewicht Ağırlık	1,60
Dimensioni Dimensions Abmessungen Dimensioner (AxBxH)	Dimensions Διαστάσεις	Dimensões Afmetingen Boyutlar	223x128x265 (LxWxH)

EN 12549 :2009 EN ISO 4871 :2009	Pressione sonora in pos. operatore Sound pressure in operator's position Schalldruck am Arbeitsplatz Ljudtryck på operatörsplatsen	Pression sonore poste Opérateur Presión sonora en la pos. del operador Ηχητική πίεση στη θέση του χειριστή Operatör pozisyonunda ses basıncı	84,3 dB(A) (K= 4 dB)
EN 12549 :2009 EN ISO 3746 :2011 EN ISO 4871 :2009	Potenza sonora emessa Sound power emitted Emitierte Schalleistung Avgiven ljudeffekt	Puissance sonore émise Potencia sonora emitida Εκπεμπόμενη ηχητική ισχύς	93,7 dB(A) (K= 4 dB)
CEN ISO/TS 8662-11 :2006 EN ISO 5349-2 :2004 EN 12096 :1999	Emissione vibratoria sull'impugnatura Vibratory emissions on handle Vibrationsemission am Griff Vibrationsemission på handtaget	Émission vibratoire sur la prise en main Emisión de vibraciones en la empuñadura Εκπεμπόμενες δονήσεις στη λαβή Tutamak üzerinde vibrasyon emisyonları	<2,5 m/s² (K= 2 m/s²)

Tipo di punto
Type of fastener
Befestigungsmittel
Tipo de rivet
Tipo de punto
Τύπος αναλωσίμου
Tipo de agrafó
Type nietjes
Zimba ve çivi tipleri
Typ av stygn

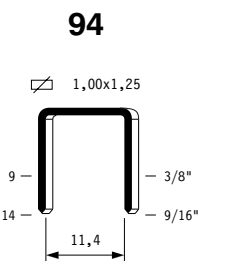

Crown: .530" (17/32")
Gauge: 18

DK25

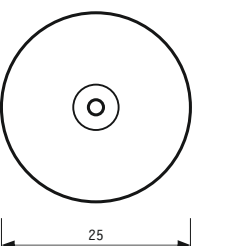

1157400DK_9414DK_5_rev21_22/05/2023 DV

Parti di ricambio - Spare parts - Ersatzteile - Pièces de rechange - Recambios
Ανταλλακτικά - Partes sobresselentes - Wisselstukken - Yedek parçalar - Reservdelar

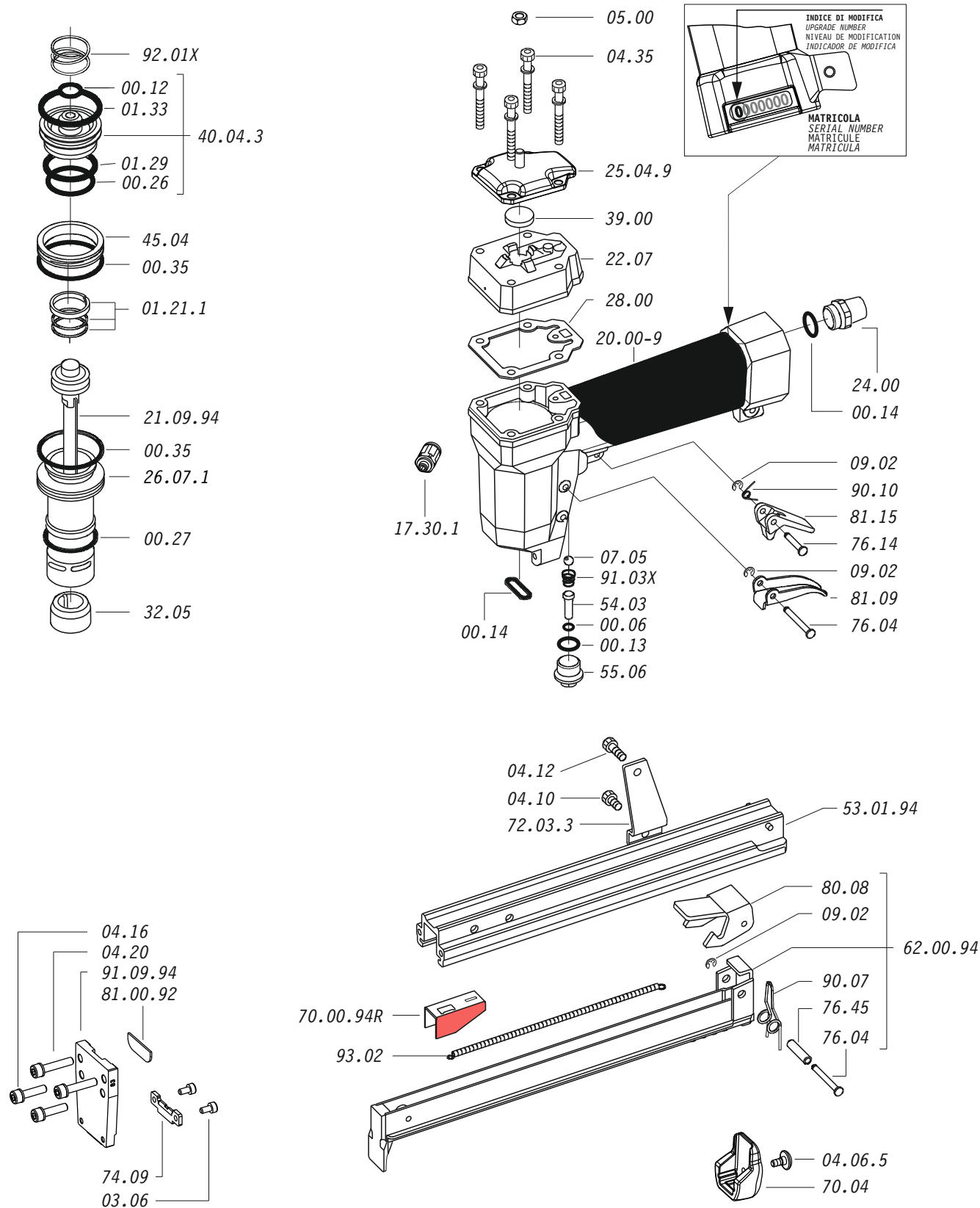

Parti di ricambio - Spare parts - Ersatzteile - Pièces de rechange - Recambios
Ανταλλακτικά - Partes sobresselentes - Wisselstukken - Yedek parçalar - Reservdelar

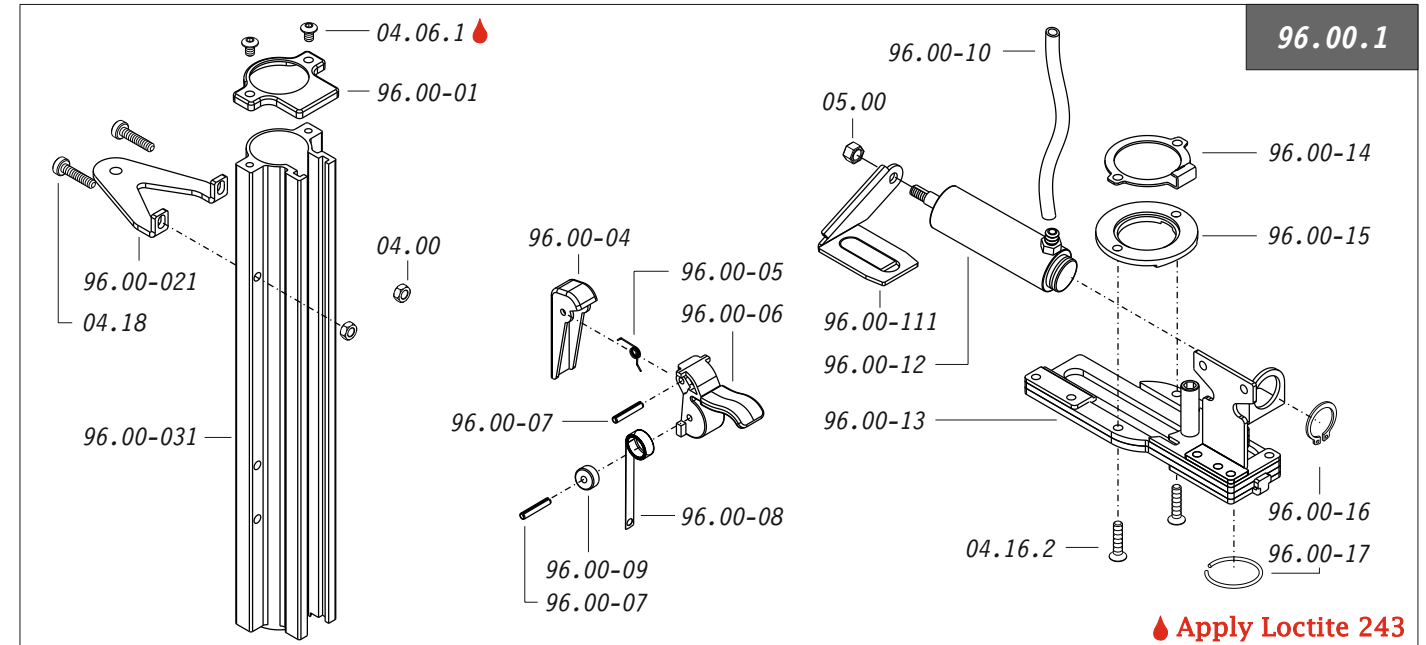

Cod.	Descrizione	Description	Cod.	Descrizione	Description	Cod.	Descrizione	Description
00.06	O-Ring	O-Ring	24.00	Silenziatore	Silencer	96.00-04	Spingidisco	Pusher
00.12	O-Ring	O-Ring	25.04.9	Deflettore	Exhaust deflector	96.00-05	Molla	Spring
00.13	O-Ring	O-Ring	26.07.1	Cilindro	Cylinder	96.00-06	Leva	Latch
00.14	O-Ring	O-Ring	28.00	Guarnizione	Gasket	96.00-07	Perno	Pin
00.26	O-Ring	O-Ring	32.05	Ammortizzatore	Bumper	96.00-08	Molla	Spring
00.27	O-Ring	O-Ring	39.00	Guarnizione scarico	Exhaust gasket	96.00-09	Rullo molla	Roller
01.21.1	Guarnizione	Gasket	40.04.3	Valvola completa	Valve ass'y	96.00-10	Tubo	Tube
01.29	O-Ring	O-Ring	45.04	Anello valvola	Ring	96.00-111	Alimentatore dischi	Disk feeder
01.33	O-Ring	O-Ring	54.03	Pulsante	Trigger valve	96.00-12	Pistone	Piston
03.06	Vite	Screw	55.06	Raccordo	Bush	96.00-13	Piastra	Plate
04.00	Dado	Nut	70.02.09K	Supporto bilanciante	Tool hangers supp.	96.00-14	Anello	Ring
04.06.1	Vite	Screw	70.04	Protezione	Guard	96.00-15	Anello	Ring
04.06.5	Vite	Screw	72.03.3	Reggicaricatore	Support	96.00-16	Anello elastico	Elastic ring
04.10	Vite	Screw	74.09	Piastrina	Plate	96.00-17	Anello	Ring
04.12	Vite	Screw	76.04	Perno	Pin	21.09.94	Battente	Driver
04.16	Vite	Screw	76.14	Perno	Pin	53.01.94	Caricatore	Magazine
04.16.2	Vite	Screw	76.45	Perno molla	Pin	62.00.94	Carrello	Slider
04.18	Vite	Screw	80.08	Grilletto chiusura	Trigger	70.00.94R	Spingipunto	Pusher
04.20	Vite	Screw	81.09	Grilletto comando	Trigger	20.00-9	Controtestina	Nose
04.20	Vite	Screw	81.15	Controgrilletto	Safety	91.09.94	Testina	Nose plate
04.35	Vite	Screw	90.07	Molla	Spring	D01	Bocchetta olio	Oiler
05.00	Dado	Nut	90.10	Molla	Spring			
07.05	Sfera	Ball	91.03X	Molla	Spring			
07.25	Chiave esagonale	Hex. bar wrench	92.01X	Molla	Spring			
07.30	Chiave esagonale	Hex. bar wrench	93.02	Molla	Spring			
09.02	Anello elastico	Elastic ring	96.00.1	Kit caricatore disc.	Magazine disk Kit			
17.30.1	Attacco	Connection	96.00-01	Tappo	Cap			
20.00-9	Corpo	Body	96.00-021	Supporto	Support			
22.07	Testa	Head	96.00-031	Caricatore dischi	Disk magazine			

Guarnizioni - O-Rings - Dichtungen - Joints toriques - Juntas
Δακτύλιος στεγανοποίησης - Vedantes - O-ringen - Contalar - O-ringar

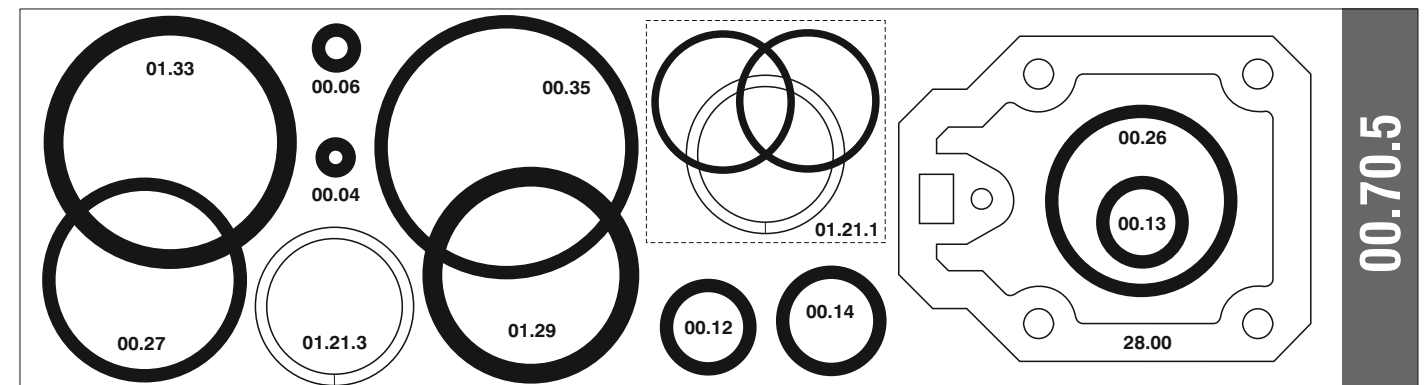

Dotazioni - Equipment - Ausstattung - Outillage - Dotaciones - Εξοπλισμός
Dotações - Uitrusting - Donanımlar - Utrustning



94.14 DK

cod. 1157400DK

94.14 DK

cod. 1157400DK

Indice di modifica
Upgrade number

5

00.70.5

Azionamento singolo con doppia attivazione

Single actuation with dual activation

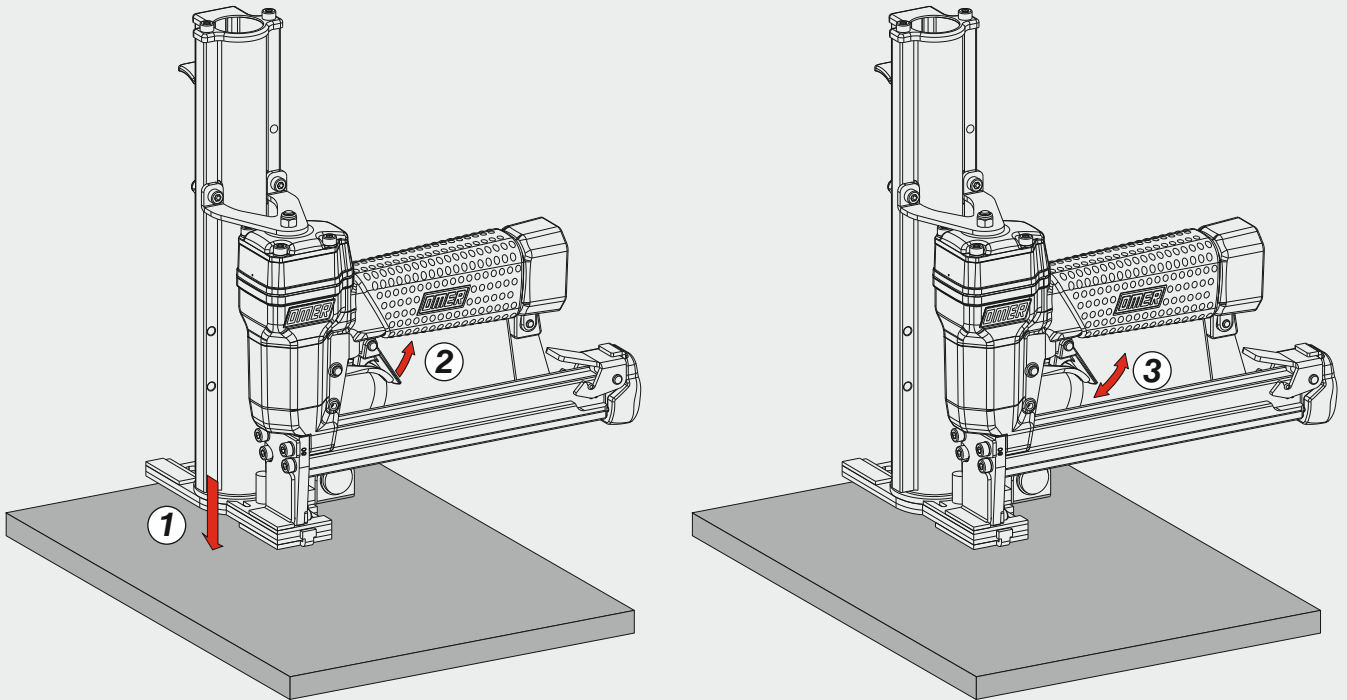

Supporto bilanciere - Tool hangers

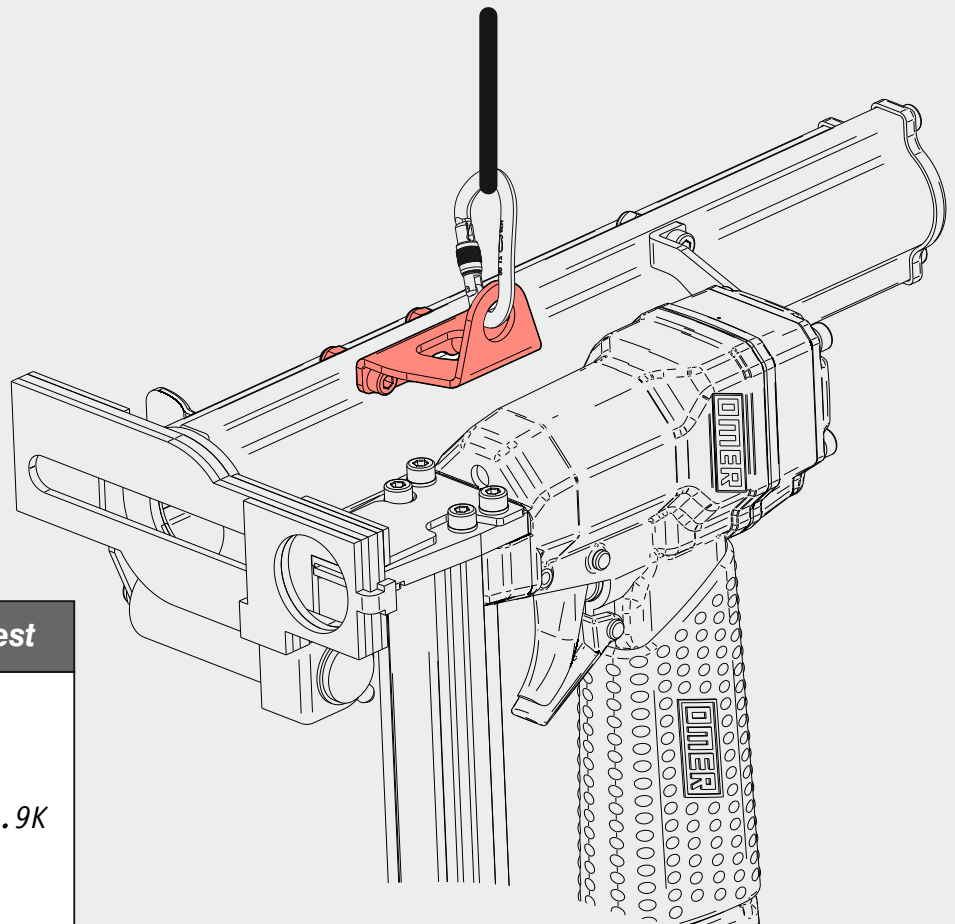

A richiesta - On request

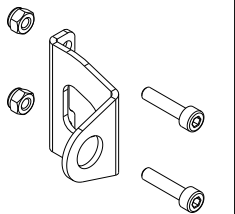

70.02.9K