

**Azionamento singolo con doppia attivazione**  
Single actuation with dual activation

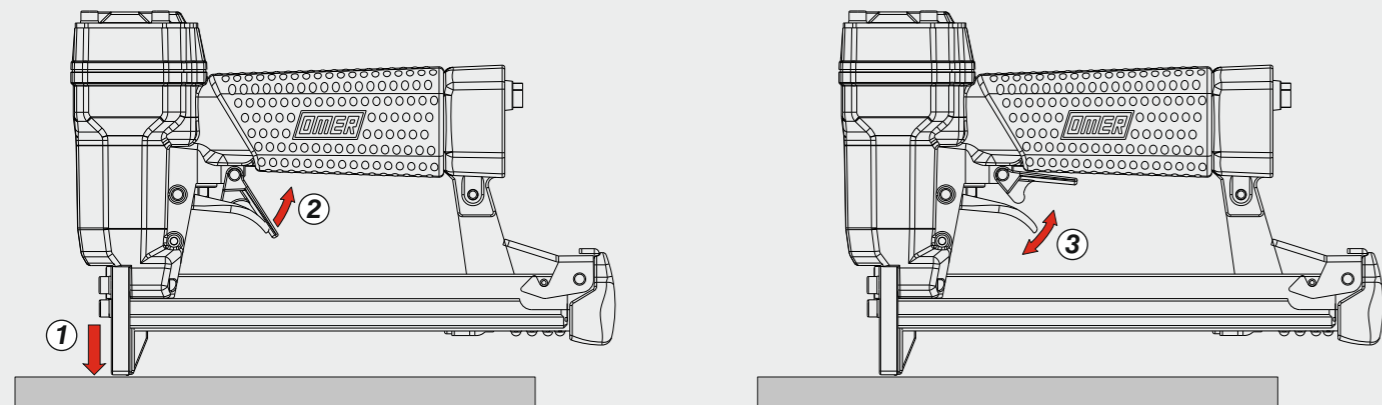

Caricamento - Loading - Laden - Chargement - Carga - Γέμισμα - Carregamento - Laden - Yükleme

**Caricamento da sotto**  
Bottom load magazine

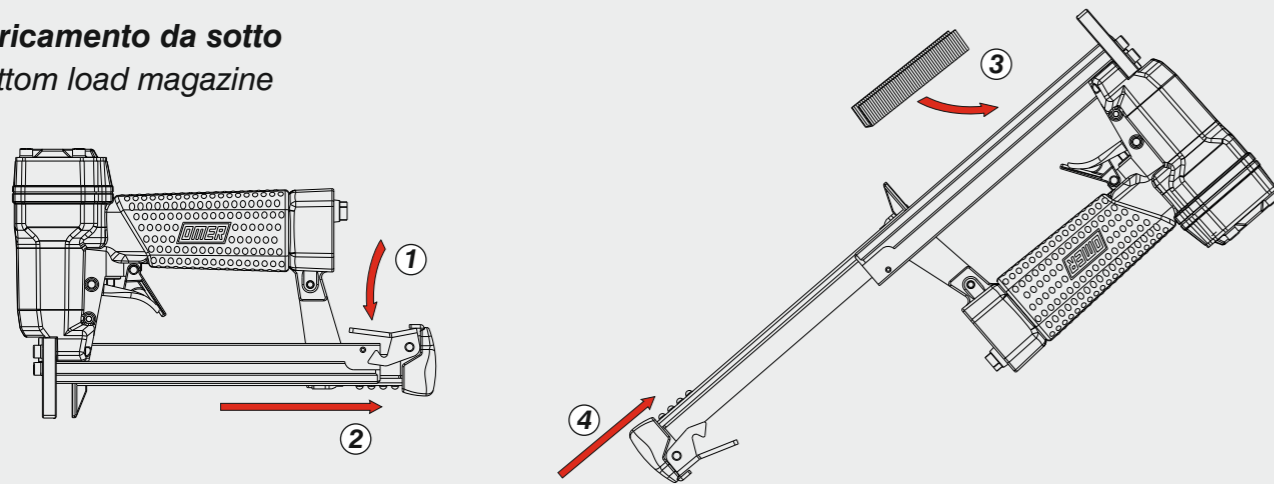

Disincerramento - Jam clearing - Staubeseitigung - Décoincement - Desatascamiento - Απεμπλοκή  
Desenclavamento - Deblokkering bij vastlopen - Sıkışma giderme

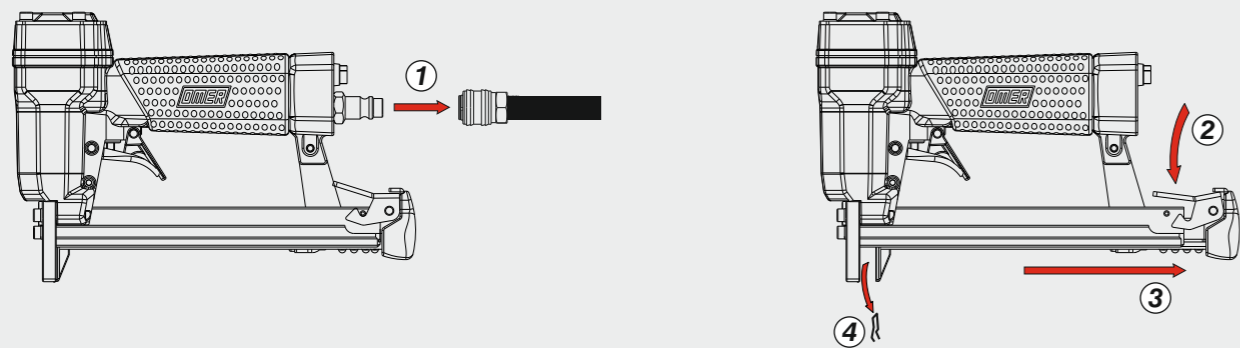

<b>Manuale d'uso, manutenzione e parti di ricambio</b>	<b>Parte 2</b>
<b>Manual for use, maintenance and spare parts</b>	<b>Part 2</b>
<b>Bedienungs- und Wartungshandbuch sowie Ersatzteilleiste</b>	<b>Teil 2</b>
<b>Mode d'emploi, de maintenance et pièces de rechange</b>	<b>Partie 2</b>
<b>Manual de uso, mantenimiento y recambios</b>	<b>Part 2</b>
<b>Εγχειρίδιο χρήσης, συντήρησης και ανταλλακτικών</b>	<b>Μέρος 2</b>
<b>Manual de uso, manutenção e peças sobresselentes</b>	<b>Parte 2</b>
<b>Handleiding voor gebruik, onderhoud en wisselstukken</b>	<b>Deel 2</b>
<b>Kullanım, bakım ve yedek parça kılavuzu</b>	<b>Kısım 2</b>



**31.16-1685**

cod. 1144200-1685



<b>Dati tecnici</b> Technical data Technische Daten	<b>Caractéristiques techniques</b> Datos técnicos Τεχνικά χαρακτηριστικά	<b>Dados técnicos</b> Technische gegevens Teknik veriler
---	--	--

<b>Misure impiegabili mm</b> Lengths mm Verwendbare Nagellänge mm	Dimensions utiles mm Medidas de longitud mm Μήκος Αναλωσίμου - mm	Medidas utilizáveis mm Toepasbare afmetingen mm Boy mm	<b>4 ÷ 16</b>
<b>Capacità caricatore n° punti</b> Magazine capacity Magazinkapazität Nägel	Capacité chargeur n° de points Capacidad cargador n° puntos Δωνατοτητα γεμιστρα	Capacidade carregador n° pontos Capaciteit magazijn in aantal spijkers Dergi kapasitesi	<b>185</b>
<b>Pressione d'esercizio</b> Operating pressure Betriebsdruck	Pression d'exercice Presión de servicio Πίεση λειτουργίας	Pressão de serviço Werkdruk Çalışma basıncı	<b>4 ÷ 6 bar 60 ÷ 90 psi</b>
<b>Consumo aria litri/colpo</b> Air consumption litres/stroke Luftverbrauch Liter/Schuss	Consommation d'air litres/coup Consumo aire litros/golpe Κατανάλωση αέρα - λίτρα/βολή	Consumo ar litros/disparo Luchtverbruik liter/slag Litre/vuruş hava tüketimi	<b>0,13</b>
<b>Peso kg</b> Weight kg Gewicht kg	Poids kg Peso kg Βάρος - kg	Peso kg Gewicht in kg Ağırlık kg	<b>0,90</b>
<b>Dimensioni mm</b> Dimensions mm Abmessungen mm	Dimensions mm Dimensiones mm Διαστάσεις mm	Dimensões mm Afmetingen mm Boyutlar mm	<b>223x43x151</b> (LxWxH)

<b>UNI EN 12549 :2009</b> <b>UNI EN ISO 4871 :2009</b>	<b>Pressione sonora in pos. operatore</b> Sound pressure in operator's position Schalldruck am Arbeitsplatz	Pression sonore poste Opérateur Presión sonora en la pos. del operador Ηχητική πίεση στη θέση του Χειριστή	Pressão sonora na posição Operador Geluidsdruk op de werkplaats Operatör pozisyonunda ses basıncı	<b>81 dB(A)</b> (K= 4 dB)
--	---	--	---	------------------------------

<b>UNI EN 12549 :2009</b> <b>UNI EN ISO 3746 :2011</b> <b>UNI EN ISO 4871 :2009</b>	<b>Potenza sonora emessa</b> Sound power emitted Emittierte Schallleistung	Puissance sonore émise Potencia sonora emitida Εκπεμπόμενη ηχητική ισχύς	Potência sonora emitida Geëmitteerd geluidsvermogen Çıkan ses gücü (ses desibel)	<b>88 dB(A)</b> (K= 4 dB)
---	--	--	--	------------------------------

<b>UNI CEN ISO/TS 8662-11 :2006</b> <b>UNI EN ISO 5349-2 :2004</b> <b>UNI EN 12096 :1999</b>	<b>Emissione vibratoria sull'impugnatura</b> Vibratory emissions on handle Vibrationsemission am Griff	Émission vibratoire sur la prise en main Emisión de vibraciones en la empuñadura Εκπεμπόμενες δονήσεις στη λαβή	Emissão vibratória na empunhadura Trillingsemissie op de handgreep Tutamak üzerinde vibrasyon emisyonları	<b>&lt;2,5 m/s<sup>2</sup></b> (K= 2 m/s <sup>2</sup> )
--	--	---	---	--

**Tipo di punto**  
Type of fastener  
Befestigungsmittel  
Type de rivet  
Tipo de punto  
Τύπος αναλωσίμου  
Tipo de agrafa  
Type nietjes  
Zimba ve çivi tipleri

**31**

0,55x0,75

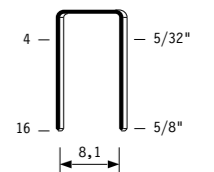

Crown: .370" (3/8")  
Gauge: 22

Parti di ricambio - Spare parts - Ersatzteile - Pièces de rechange - Recambios  
Ανταλλακτικά - Partes sobresselentes - Wisselstukken - Yedek parçalar

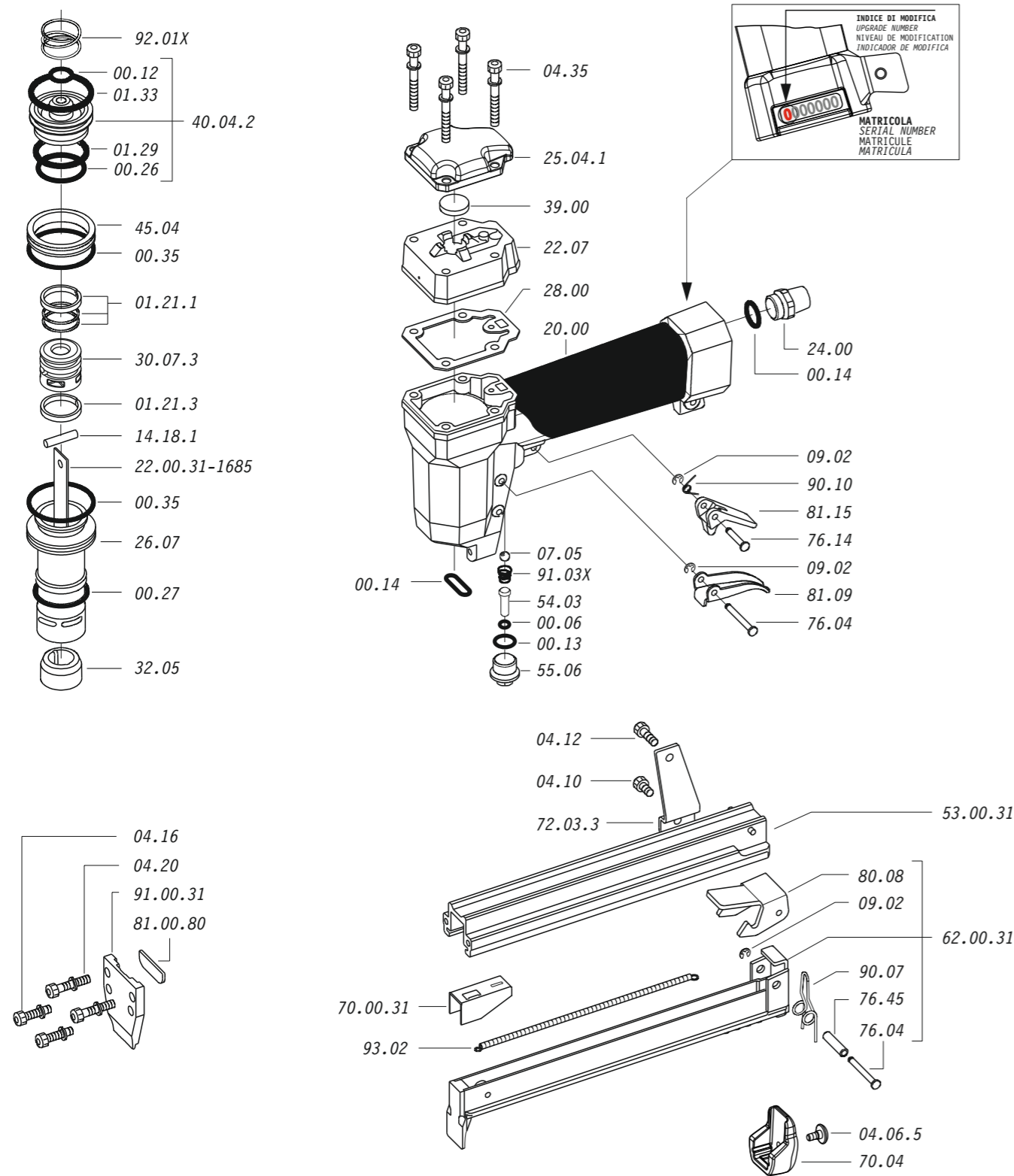

Dotazioni - Equipment - Ausstattung - Outillage - Dotaciones - Εξοπλισμός  
Dotações - Uitrusting - Donanımlar

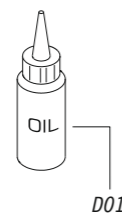

**31.16-1685**

cod. 1144200-1685

Parti di ricambio - Spare parts - Ersatzteile - Pièces de rechange - Recambios  
Ανταλλακτικά - Partes sobresselentes - Wisselstukken - Yedek parçalar

Cod.	Descrizione	Description
00.06	O-Ring	O-Ring
00.12	O-Ring	O-Ring
00.13	O-Ring	O-Ring
00.14	O-Ring	O-Ring
00.26	O-Ring	O-Ring
00.27	O-Ring	O-Ring
00.35	O-Ring	O-Ring
01.21.1	Guarnizione	Gasket
01.21.3	Guarnizione	Gasket
01.29	O-Ring	O-Ring
01.33	O-Ring	O-Ring
04.06.5	Vite	Screw
04.10	Vite	Screw
04.12	Vite	Screw
04.16	Vite	Screw
04.20	Vite	Screw
04.35	Vite	Screw
07.05	Sfera	Ball
07.30	Chiave esagonale	Hex. bar wrench
09.02	Anello elastico	Elastic ring
14.18.1	Spina	Pin
20.00	Corpo	Body
22.07	Testa	Head
24.00	Silenziatore	Silencer
25.04.1	Deflettore	Exhaust deflector
26.07	Cilindro	Cylinder
28.00	Guarnizione	Gasket
30.07.3	Pistone	Piston
32.05	Ammortizzatore	Bumper
39.00	Guarnizione scarico	Exhaust gasket
40.04.2	Valvola completa	Valve ass'y
45.04	Anello valvola	Ring
54.03	Pulsante	Trigger valve
55.06	Raccordo	Bush
70.04	Protezione	Guard
72.03.3	Reggicaricatore	Support
76.04	Perno	Pin
76.14	Perno	Pin
76.45	Perno molla	Pin
80.08	Grilletto chiusura	Trigger
81.09	Grilletto comando	Trigger
81.15	Controgrilletto	Safety
90.07	Molla	Spring
90.10	Molla	Spring
91.03X	Molla	Spring
92.01X	Molla	Spring
93.02	Molla	Spring
22.00.31-1685	Battente	Driver
53.00.31	Caricatore	Magazine
62.00.31	Carrello	Slider
70.00.31	Spingipunto	Pusher
81.00.80	Controtestina	Nose
91.00.31	Testina	Nose plate
D01	Bocchetta olio	Oiler

Guarnizioni - O-Rings - Dichtungen - Joints toriques - Juntas - Δακτύλιος στεγανοποίησης - Vedantes - O-ringen - Contalar

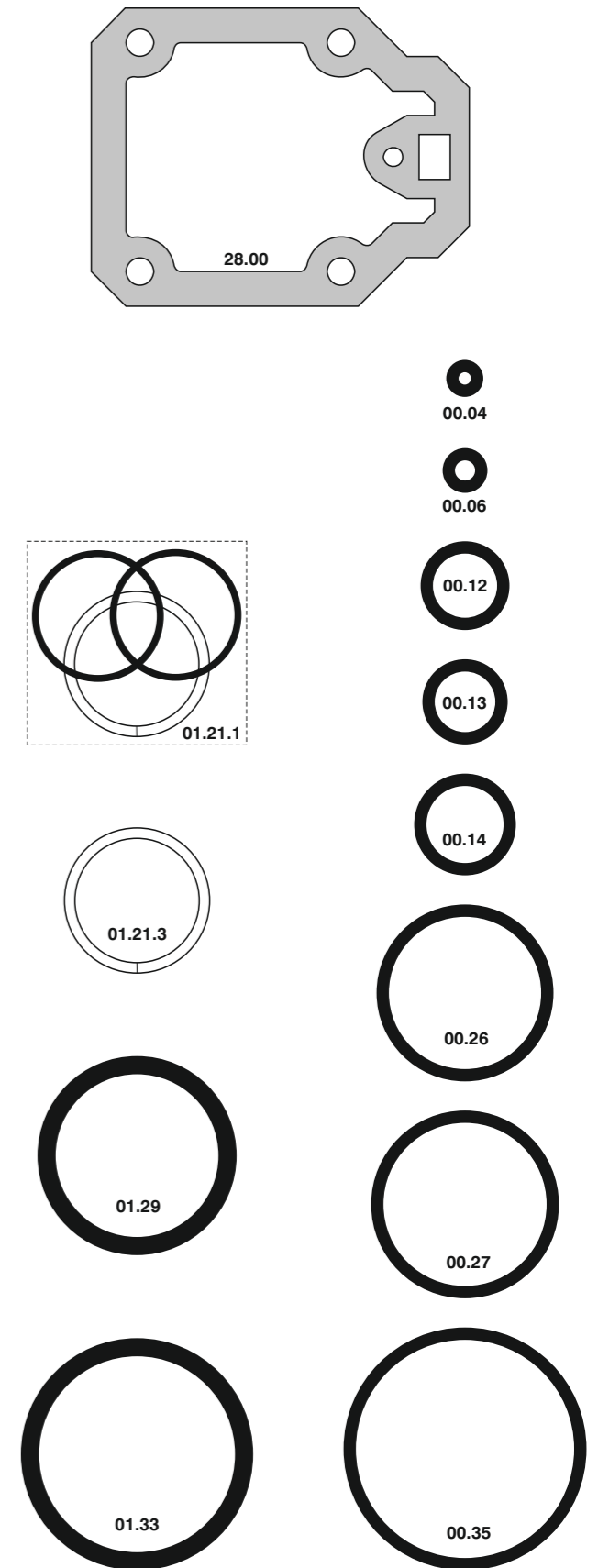

00.70.5

**31.16-1685**

cod. 1144200-1685

Indice di modifica  
Upgrade number

**6**