

Collegamento - Connection

Collegamento:
Connection:

Valvola 3/2 NC
Valve 3/2 NC

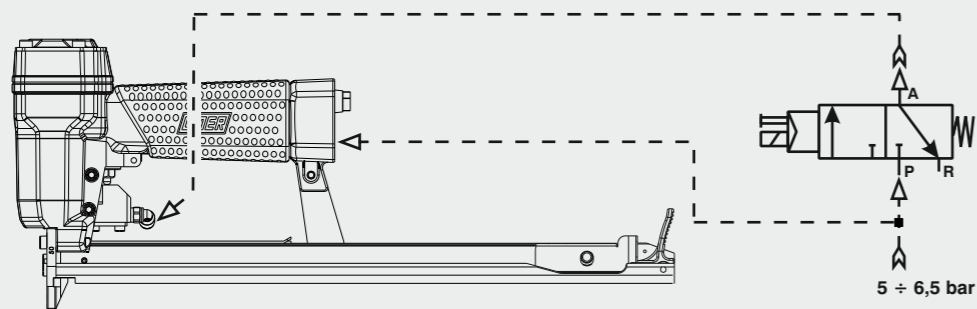

OMER

Manuale d'uso, manutenzione e parti di ricambio	Parte 2
Manual for use, maintenance and spare parts	Part 2
Bedienungs- und Wartungshandbuch sowie Ersatzteilleiste	Teil 2
Mode d'emploi, de maintenance et pièces de rechange	Partie 2
Manual de uso, mantenimiento y recambios	Part 2
Εγχειρίδιο χρήσης, συντήρησης και ανταλλακτικών	Μέρος 2
Manual de uso, manutenção e peças sobresselentes	Parte 2
Handleiding voor gebruik, onderhoud en wisselstukken	Deel 2
Kullanım, bakım ve yedek parça kılavuzu	Kısım 2
Användar-, underhålls- och reservdelshandbok	Del 2



Caricamento - Loading - Laden - Chargement - Carga - Γέμισμα - Carregamento - Laden - Yükleme - Laddning

Caricamento da sopra
Top load magazine

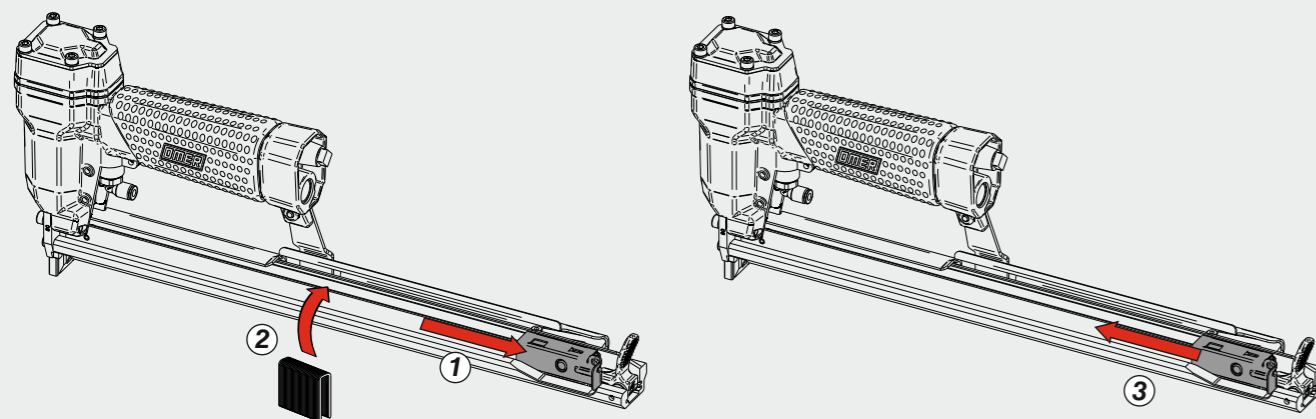

Disinceppamento - Jam clearing - Staubeseitigung - Décoincement - Desatascamiento - Απεμπλοκή
Desenclavamento - Deblokkering bij vastlopen - Σίκισμα giderme - Rensning av igensättning

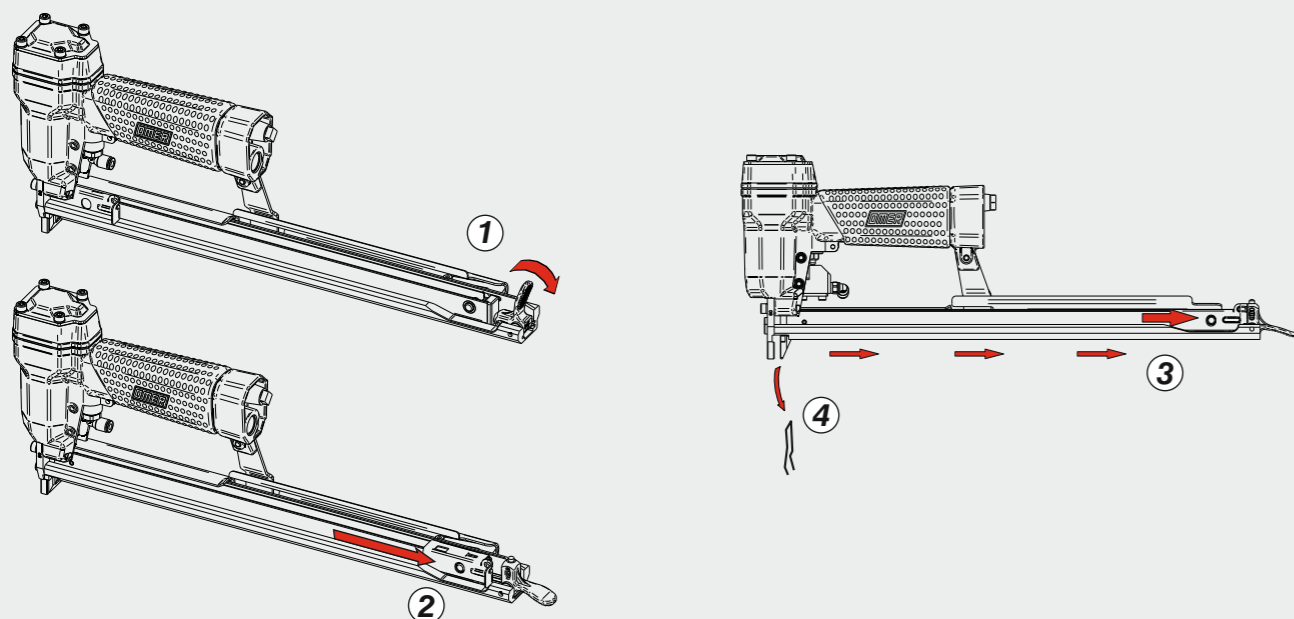

SJK.16 CLT-3

cod. 11526540-3



Dati tecnici

Technical data
Technische Daten
Tekniska data

Caractéristiques techniques

Datos técnicos
Τεχνικά χαρακτηριστικά

Dados técnicos

Technische gegevens
Teknik veriler

Misure impiegabili

Lengths
Verwendbare Nagellänge
Dimensioner som kan användas

Dimensions utiles

Medidas de longitud
Μήκος Αναλωσίμου

Medidas utilizáveis

Toepasbare afmetingen
Boy

mm
inch

4 - 16
5/32" - 5/8"

Capacità caricatore n° punti

Magazine capacity
Magazinkapazität Nägel
Magasinkapacitet Antal punkter

Capacité chargeur n° de points

Capacidad cargador n° puntos
Δυνατότητα γεμιστέρα

Capacidade carregador n° pontos

Capaciteit magazijn in aantal spijkers
Dergi kapasitesi

360

Pressione d'esercizio

Operating pressure
Betriebsdruck
Drifttryck

Pression d'exercice

Presión de servicio
Πίεση λειτουργίας

Pressão de serviço

Werkdruk
Çalışma basıncı

bar
psi

4 - 6
60 - 90

Consumo aria

Air consumption
Luftverbrauch
Luftförbrukning

Consommation d'air

Consumo aire
Κατανάλωση αέρα

Consumo ar

Luchtverbruik
Hava tüketimi

lt/colpo
ft³/cycle

0,13
0,00459

Peso

Weight
Gewicht
Vikt

Poids

Peso
Βάρος

Peso

Gewicht
Ağırlık

kg
lbs

1,17
2,57

Dimensioni

Dimensions
Abmessungen
Dimensioner (AxBxH)

Dimensions

Dimensiones
Διαστάσεις

Dimensões

Afmetingen
Boyutlar

mm
inch

378x43x148
14-7/8"x1-11/16"x5-13/16"

(LxWxH)

EN 12549 :2009 EN ISO 3746 :2011 EN ISO 4871 :2009

Potenza sonora emessa

Sound power emitted
Emittierte Schalleistung
Avgiven ljudeffekt

Puissance sonore émise

Potencia sonora emitida
Eκπεμπόμενη ηχητική ισχύς

Potência sonora emitida

Geëmitteerd geluidsvermogen
Çıkan ses gücü (ses desibeli)

dB(A)

88

(K = 4 dB)

Tipo di punto

Type of fastener
Befestigungsmittel
Type de rivet
Tipo de punto
Τύπος αναλωσίμου
Type nietjes
Zimba ve çivi tipleri
Typ av stygn

SJK

0,55x0,75

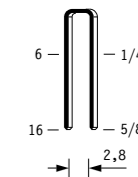

Gauge: 23
Crown: .153" (5/32")

11526540-3_SJK16CLT-4_5_rev21_21/03/2024_DV

**DO NOT
HANDHELD
THIS TOOL**



Parti di ricambio - Spare parts - Ersatzteile - Pièces de rechange - Recambios
Ανταλλακτικά - Partes sobresselentes - Wisselstukken - Yedek parçalar - Reservdelar

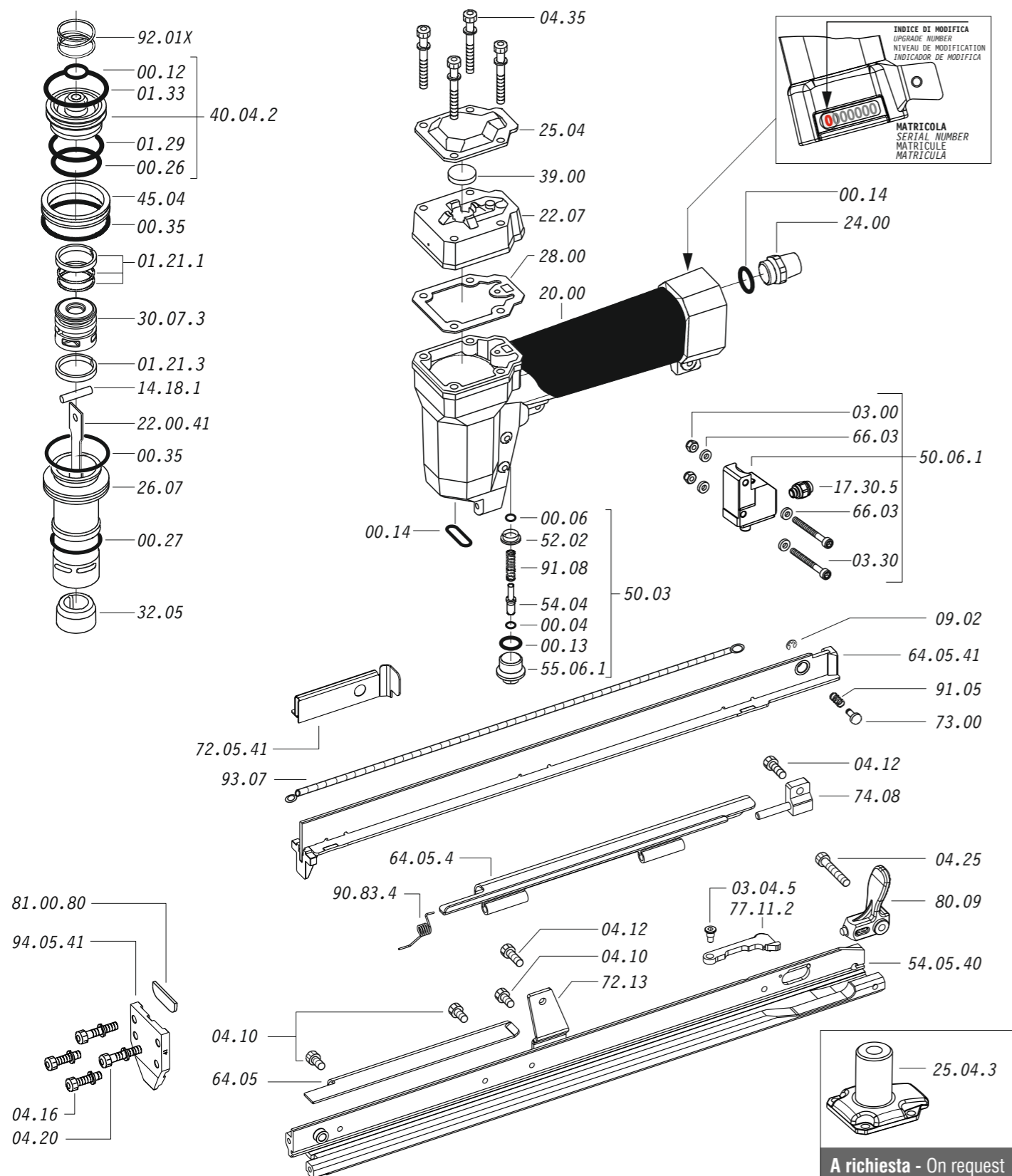

Dotazioni - Equipment - Ausstattung - Outillage - Dotaciones - Εξοπλισμός
Dotações - Uitrusting - Donanimlar - Utrustning

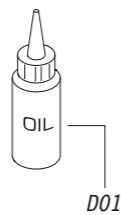

SJK.16 CLT-3

cod. 11526540-3

Parti di ricambio - Spare parts - Ersatzteile - Pièces de rechange - Recambios
Ανταλλακτικά - Partes sobresselentes - Wisselstukken - Yedek parçalar - Reservdelar

Cod.	Descrizione	Description
00.04	O-Ring	O-Ring
00.06	O-Ring	O-Ring
00.12	O-Ring	O-Ring
00.13	O-Ring	O-Ring
00.14	O-Ring	O-Ring
00.26	O-Ring	O-Ring
00.27	O-Ring	O-Ring
00.35	O-Ring	O-Ring
01.21.1	Guarnizione	Gasket
01.21.3	Guarnizione	Gasket
01.29	O-Ring	O-Ring
01.33	O-Ring	O-Ring
03.00	Dado	Nut
03.04.5	Vite	Screw
03.30	Vite	Screw
04.10	Vite	Screw
04.12	Vite	Screw
04.16	Vite	Screw
04.20	Vite	Screw
04.25	Vite	Screw
04.35	Vite	Screw
07.30	Chiave esagonale	Hex. bar wrench
09.02	Anello elastico	Elastic ring
14.18.1	Spina	Pin
17.30.5	Attacco	Connection
20.00	Corpo	Body
22.07	Testa	Head
24.00	Silenziatore	Silencer
25.04	Deflettore	Exhaust deflector
25.04.3	Supporto	Support
26.07	Cilindro	Cylinder
28.00	Guarnizione	Gasket
30.07.3	Pistone	Piston
32.05	Ammortizzatore	Bumper
39.00	Guarnizione scarico	Exhaust gasket
40.04.2	Valvola completa	Valve ass'y
45.04	Anello valvola	Ring
50.03	Pulsante completo	Trigger valve ass'y
50.06.1	Comando a distanza	Remote control
52.02	Boccola	Bush
54.04	Pulsante	Trigger valve
55.06.1	Raccordo	Bush
64.05	Carter	Hold down
64.05.4	Carter mobile	Hold down
66.03	Rondella	Washer
72.13	Reggicaricatore	Support
73.00	Perno	Pin
74.08	Staffa	Support
77.11.2	Leva	Lever
80.09	Grilletto chiusura	Trigger
91.05	Molla	Spring
91.08	Molla	Spring
90.83.4	Molla	Spring
92.01X	Molla	Spring
93.07	Molla	Spring
22.00.41	Battente	Driver
54.05.40	Caricatore	Magazine
64.05.41	Carrello	Slider
72.05.41	Spingipunto	Pusher
81.00.80	Controtestina	Nose
94.05.41	Testina	Nose plate
D01	Bocchetta olio	Oiler

Guarnizioni - O-Rings - Dichtungen - Joints toriques - Junta - Δακτύλιος στεγανοποίησης - Vedantes - O-ringen - Contalar - O-ringar

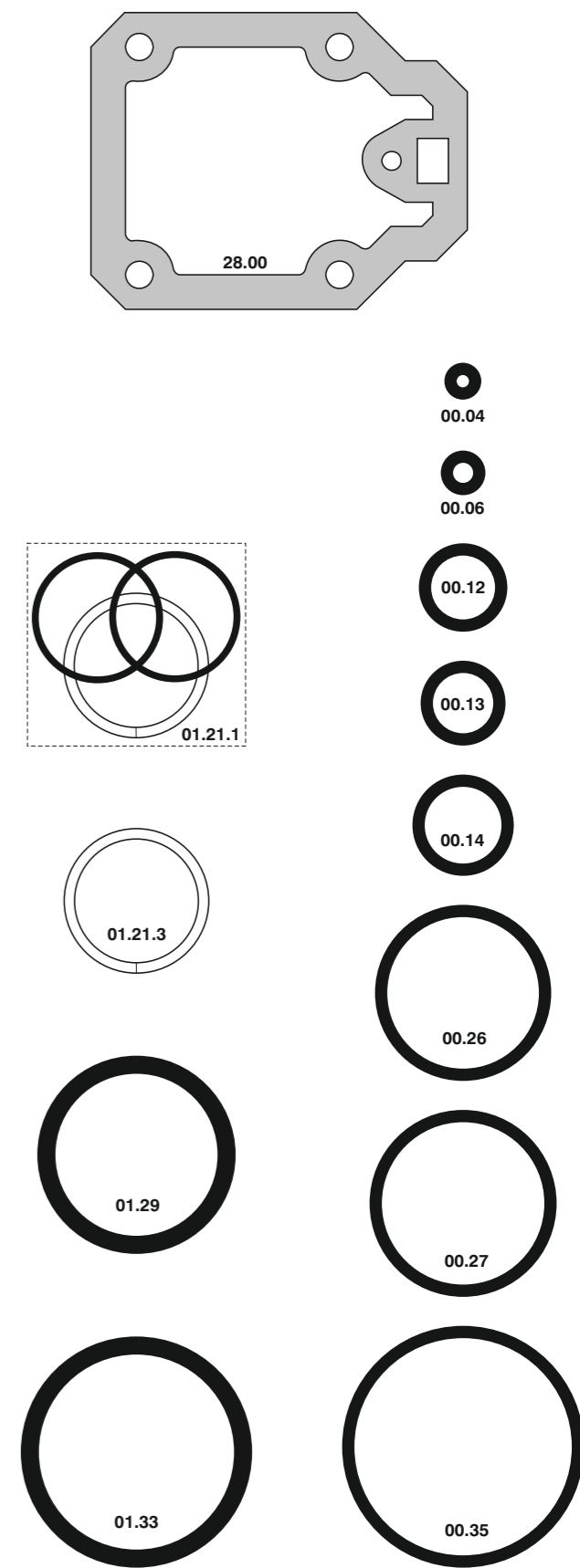

SJK.16 CLT-3

cod. 11526540-3

Indice di modifica
Upgrade number

5