

Collegamento - Connection

Collegamento:
Connection:

Valvola 3/2 NA
Valve 3/2 NO

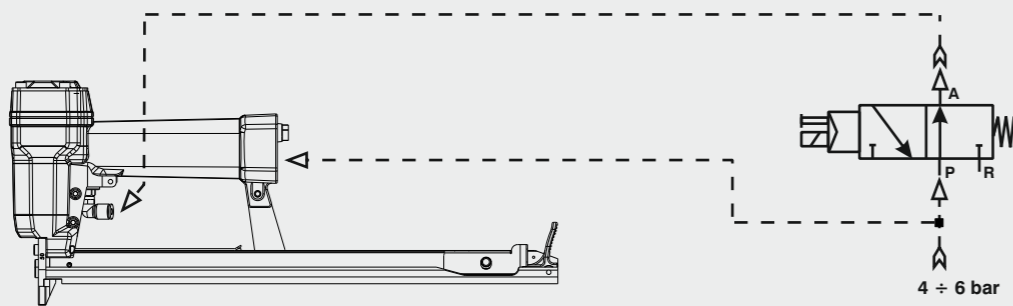

Caricamento - Loading - Laden - Chargement - Carga - Γέμισμα - Carregamento - Laden - Yükleme

Caricamento da sopra
Top load magazine

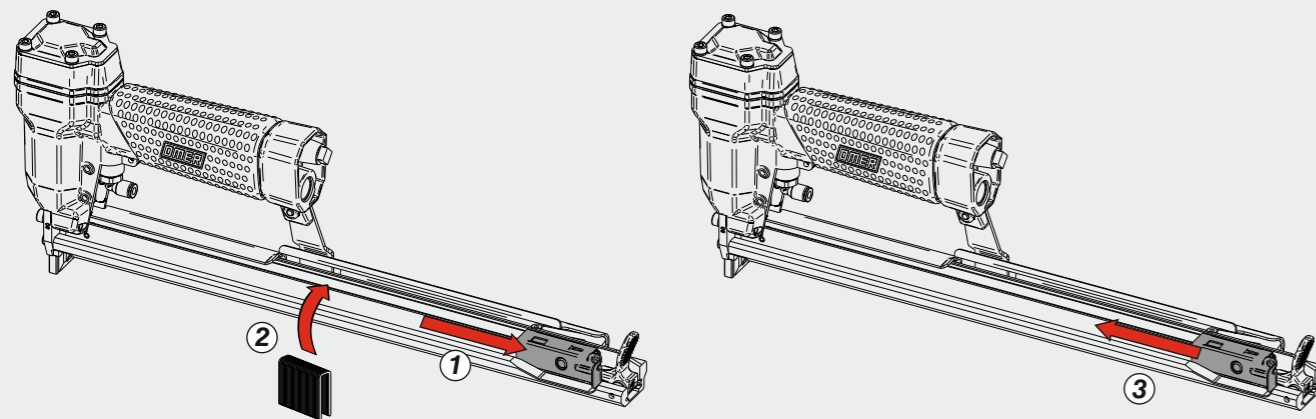

Disinceppamento - Jam clearing - Staubeseitigung - Décoincement - Desatascamiento - Απεμπλοκή
Desencravamento - Deblokkering bij vastlopen - Sıkışma giderme

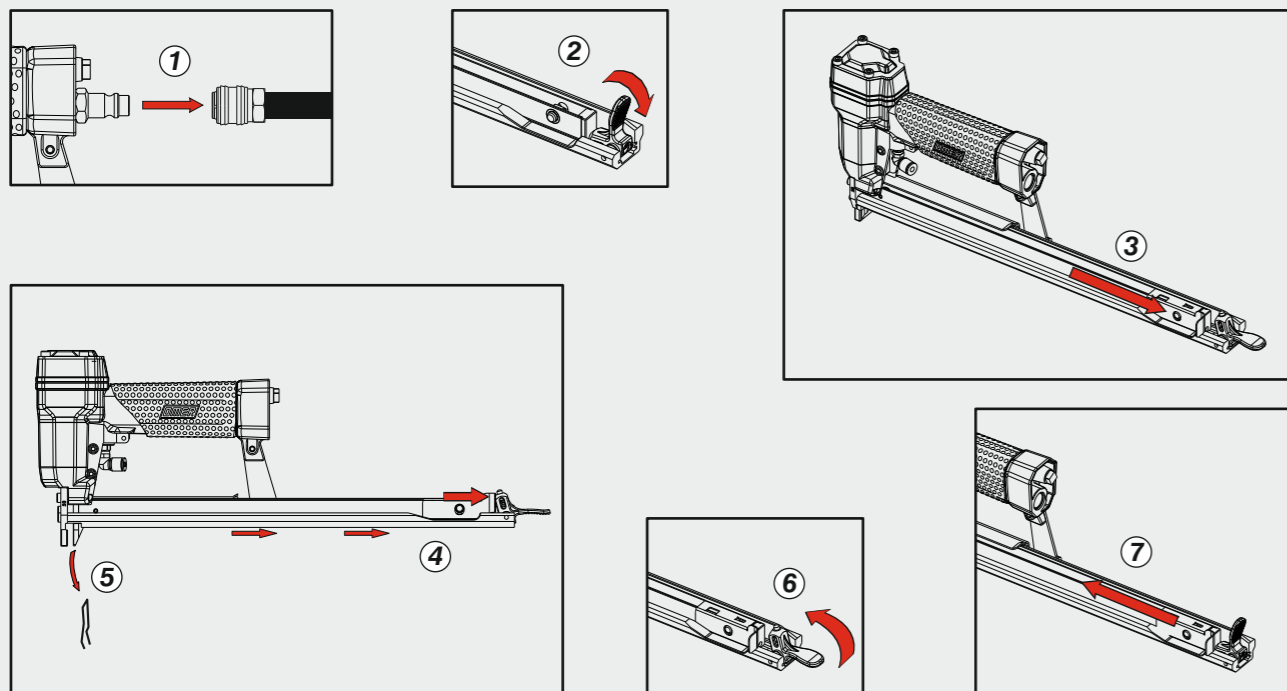

OMER®

Manuale d'uso, manutenzione e parti di ricambio
Manual for use, maintenance and spare parts
Bedienungs- und Wartungshandbuch sowie Ersatzteilleiste
Mode d'emploi, de maintenance et pièces de rechange
Manual de uso, mantenimiento y recambios
Εγχειρίδιο χρήσης, συντήρησης και ανταλλακτικών
Manual de uso, manutenção e peças sobresselentes
Handleiding voor gebruik, onderhoud en wisselstukken
Kullanım, bakım ve yedek parça kılavuzu

Parte 2
Part 2
Teil 2
Partie 2
Part 2
Μέρος 2
Parte 2
Deel 2
Kısım 2



62.16 CLT

cod. 11552540

| Dati tecnici Technical data Technische Daten | Caractéristiques techniques Datos técnicos Τεχνικά χαρακτηριστικά | Dados técnicos Technische gegevens Teknik veriler |
|--|---|---|
| Misure impiegabili mm Lengths mm Verwendbare Nagellänge mm | Dimensions utiles mm Medidas de longitud mm Μήκος Αναλωσίμου - mm | Medidas utilizáveis mm Toepasbare afmetingen mm Boy mm |
| Capacità caricatore n° punti Magazine capacity Magazinkapazität Nägel | Capacité chargeur n° de points Capacidad cargador n° puntos Δωνατοτητα γεμιστερα | Capacidade carregador n° pontos Capaciteit magazijn in aantal spijkers Dergi kapasitesi |
| Pressione d'esercizio Operating pressure Betriebsdruck | Pression d'exercice Presión de servicio Πίεση λειτουργίας | Pressão de serviço Werkdruk Çalışma basıncı |
| Consumo aria litri/colpo Air consumption litres/stroke Luftverbrauch Liter/Schuss | Consommation d'air litres/coup Consumo aire litros/golpe Κατανάλωση αέρα - λίτρα/βολή | Consumo ar litros/disparo Luchtverbruik liter/slag Litre/vuruş hava tüketimi |
| Peso kg Weight kg Gewicht kg | Poids kg Peso kg Βάρος - kg | Peso kg Gewicht in kg Ağırlık kg |
| Dimensioni mm Dimensions mm Abmessungen mm | Dimensions mm Dimensiones mm Διαστάσεις mm | Dimensões mm Afmetingen mm Boyutlar mm |
| UNI EN 12549 :2009 | UNI EN ISO 3746 :2011 | UNI EN ISO 4871 :2009 |
| Potenza sonora emessa Sound power emitted Emittierte Schallleistung | Puissance sonore émise Potencia sonora emitida Εκπεμπόμενη ηχητική ισχύς | Potência sonora emitida Geëmitteerd geluidsvermogen Çıkan ses gücü (ses desibeli) |

Tipo di punto
Type of fastener
Befestigungsmittel
Type de rivet
Τύπος αναλωσίμου
Tipo de agrafa
Type nietjes
Zimba ve çivi tipleri

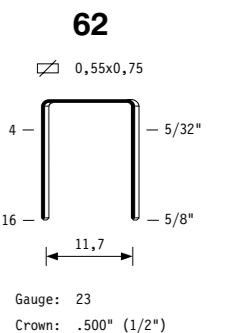

11552540_6216CLT_5_rev20_22/03/2024 DV

**DO NOT
HANDHELD
THIS TOOL**



Parti di ricambio - Spare parts - Ersatzteile - Pièces de rechange - Recambios
Ανταλλακτικά - Partes sobresselentes - Wisselstukken - Yedek parçalar

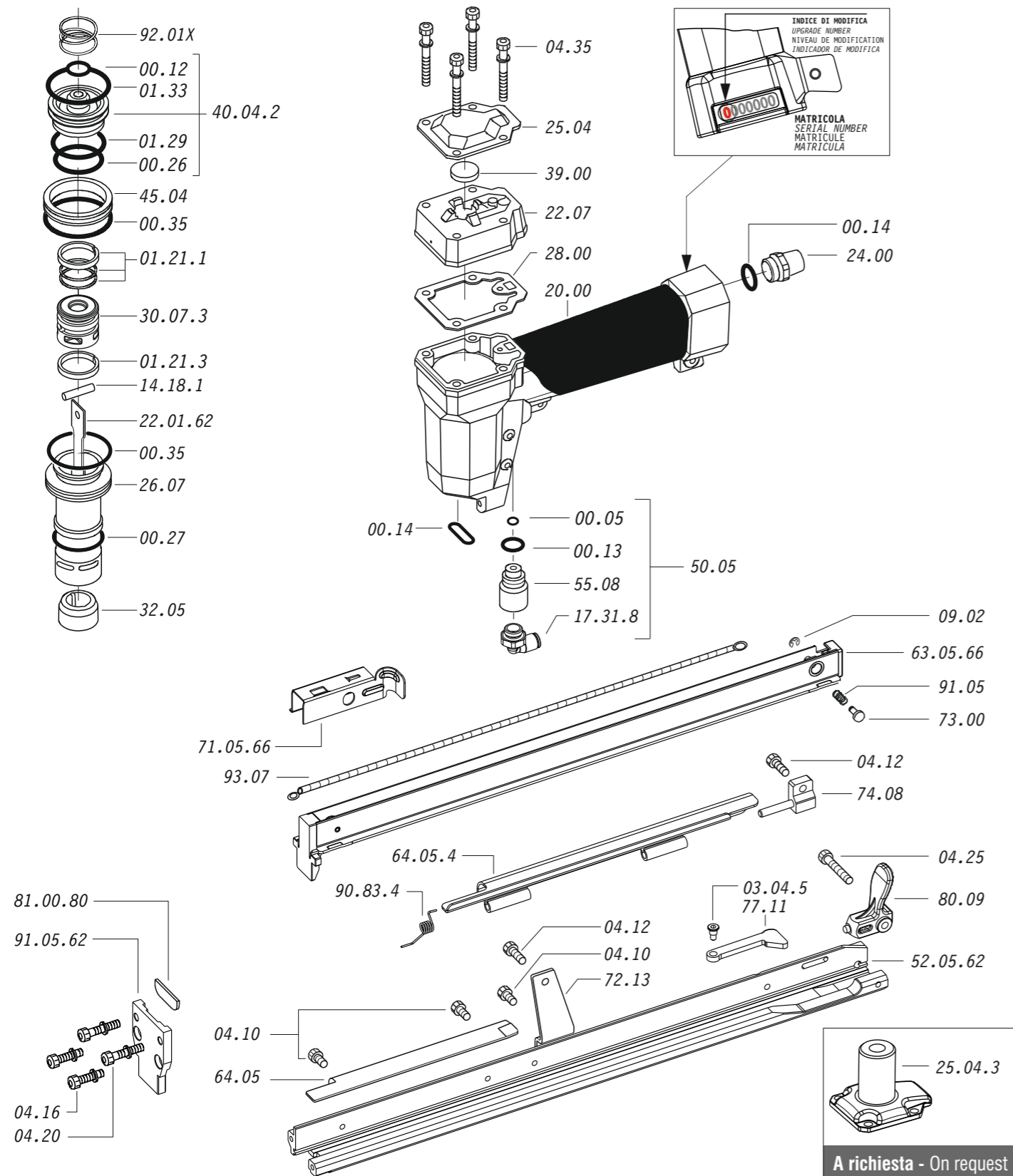

Dotazioni - Equipment - Ausstattung - Outillage - Dotaciones - Εξοπλισμός
Dotações - Uitrusting - Donanımlar

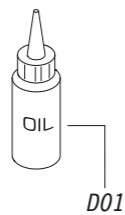

62.16 CLT

cod. 11552540

Parti di ricambio - Spare parts - Ersatzteile - Pièces de rechange - Recambios
Ανταλλακτικά - Partes sobresselentes - Wisselstukken - Yedek parçalar

| Cod. | Descrizione | Description |
|----------|---------------------|------------------------|
| 00.05 | O-Ring | O-Ring |
| 00.12 | O-Ring | O-Ring |
| 00.13 | O-Ring | O-Ring |
| 00.14 | O-Ring | O-Ring |
| 00.26 | O-Ring | O-Ring |
| 00.27 | O-Ring | O-Ring |
| 00.35 | O-Ring | O-Ring |
| 01.21.1 | Guarnizione | Gasket |
| 01.21.3 | Guarnizione | Gasket |
| 01.29 | O-Ring | O-Ring |
| 01.33 | O-Ring | O-Ring |
| 03.04.5 | Vite | Screw |
| 04.10 | Vite | Screw |
| 04.12 | Vite | Screw |
| 04.16 | Vite | Screw |
| 04.20 | Vite | Screw |
| 04.25 | Vite | Screw |
| 04.35 | Vite | Screw |
| 07.30 | Chiave esagonale | Hex. bar wrench |
| 09.02 | Anello elastico | Elastic ring |
| 14.18.1 | Spina | Pin |
| 17.31.8 | Attacco | Connection |
| 20.00 | Corpo | Body |
| 22.07 | Testa | Head |
| 24.00 | Silenziatore | Silencer |
| 25.04 | Deflettore | Exhaust deflector |
| 25.04.3 | Supporto | Support |
| 26.07 | Cilindro | Cylinder |
| 28.00 | Guarnizione | Gasket |
| 30.07.3 | Pistone | Piston |
| 32.05 | Ammortizzatore | Bumper |
| 39.00 | Guarnizione scarico | Exhaust gasket |
| 40.04.2 | Valvola completa | Valve ass'y |
| 45.04 | Anello valvola | Ring |
| 50.05 | Comando a distanza | Remote control trigger |
| 55.08 | Raccordo | Bush |
| 64.05 | Carter | Hold down |
| 64.05.4 | Carter mobile | Hold down |
| 77.11 | Leva | Lever |
| 72.13 | Reggicaricatore | Support |
| 73.00 | Perno | Pin |
| 74.08 | Staffa | Support |
| 80.09 | Grilletto chiusura | Trigger |
| 91.05 | Molla | Spring |
| 90.83.4 | Molla | Spring |
| 92.01X | Molla | Spring |
| 93.07 | Molla | Spring |
| 22.01.62 | Battente | Driver |
| 52.05.62 | Caricatore | Magazine |
| 63.05.66 | Carrello | Slider |
| 71.05.66 | Spingipunto | Pusher |
| 81.00.80 | Controtestina | Nose |
| 91.05.62 | Testina | Nose plate |
| D01 | Bocchetta olio | Oiler |

Guarnizioni - O-Rings - Dichtungen - Juntas - Δακτύλιος στεγανοποίησης - Vedantes - O-ringen - Contalar

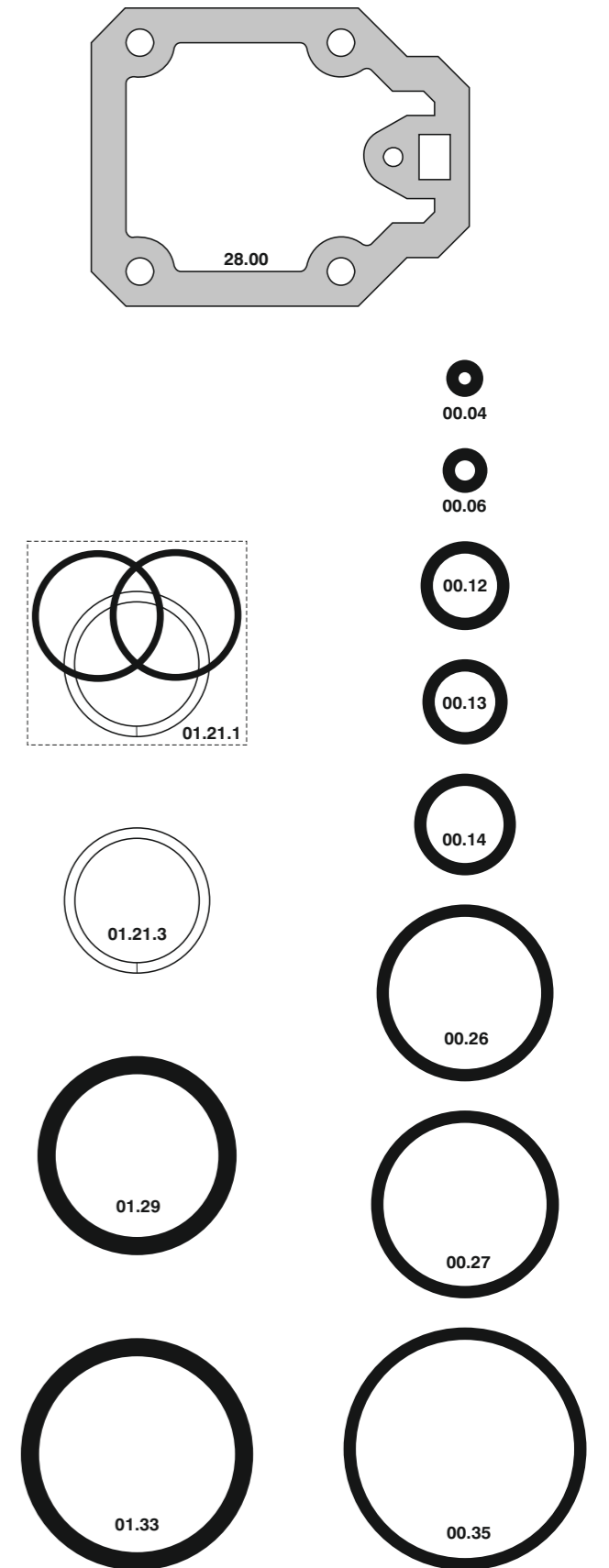

62.16 CLT

cod. 11552540

Indice di modifica
Upgrade number

5