

## Collegamento - Connection

Collegamento:  
Connection:

Valvola 3/2 NC  
Valve 3/2 NC

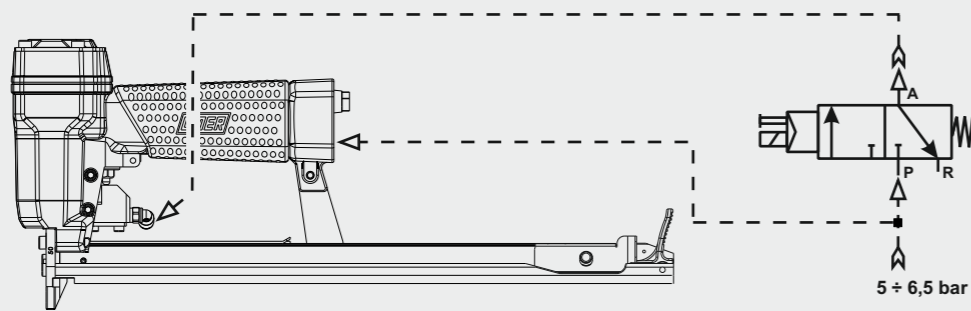

Caricamento - Loading - Laden - Chargement - Carga - Γέμισμα - Carregamento - Laden - Yükleme

Caricamento da sopra  
Top load magazine

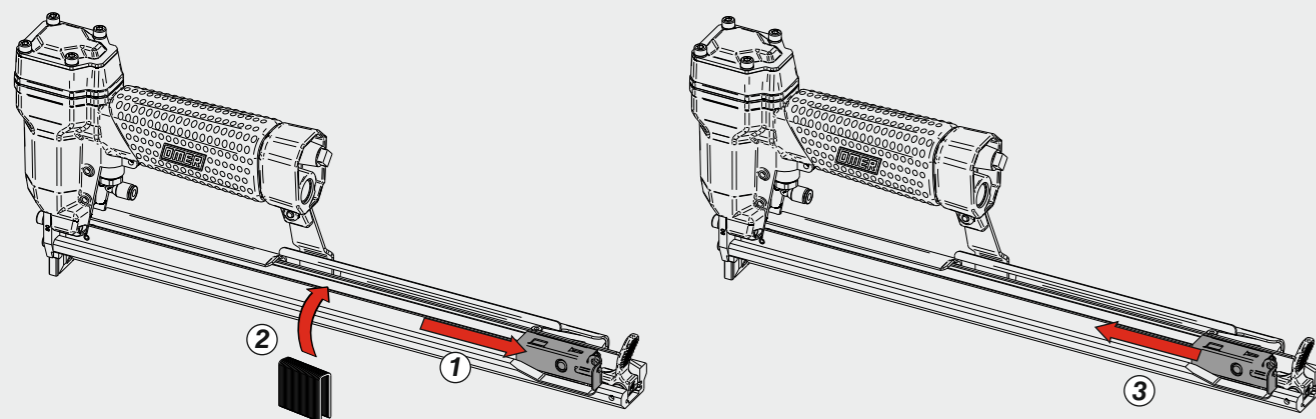

Disinceppamento - Jam clearing - Staubeseitigung - Décoincement - Desatascamiento - Απεμπλοκή  
Desencravamento - Deblokkering bij vastlopen - Sıkışma giderme

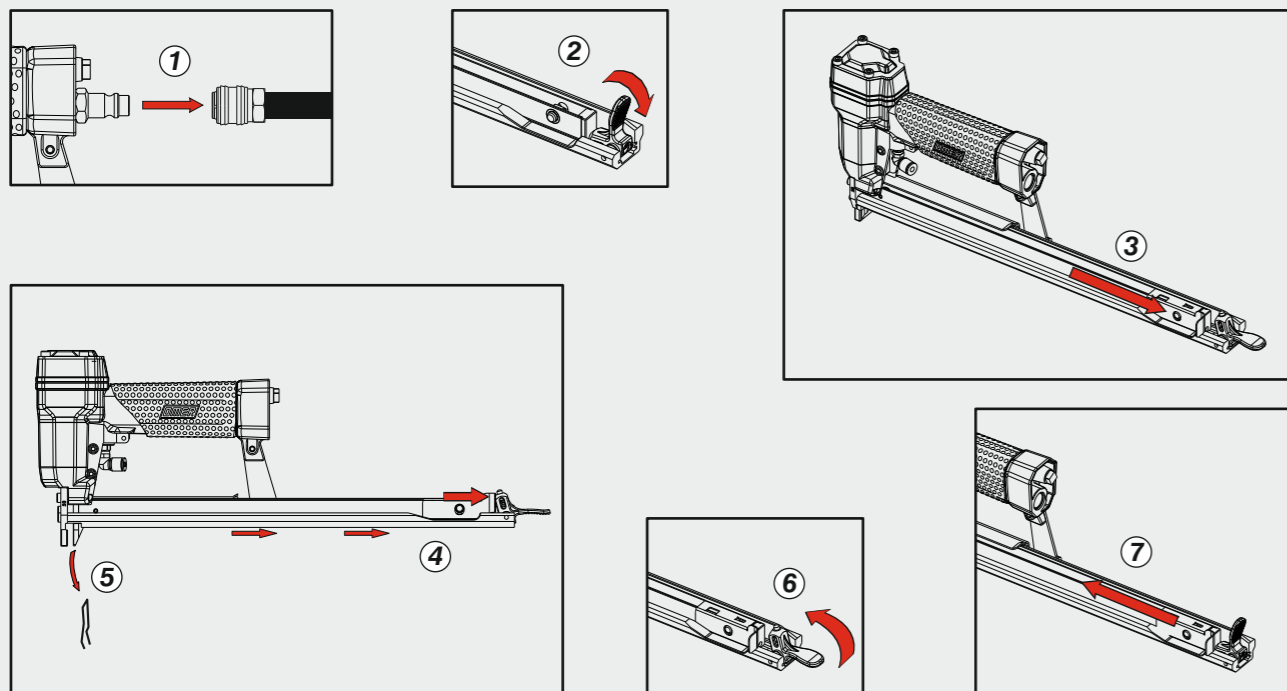

# OMER

Manuale d'uso, manutenzione e parti di ricambio  
Manual for use, maintenance and spare parts  
Bedienungs- und Wartungshandbuch sowie Ersatzteilleiste  
Mode d'emploi, de maintenance et pièces de rechange  
Manual de uso, mantenimiento y recambios  
Εγχειρίδιο χρήσης, συντήρησης και ανταλλακτικών  
Manual de uso, manutenção e peças sobresselentes  
Handleiding voor gebruik, onderhoud en wisselstukken  
Kullanım, bakım ve yedek parça kılavuzu

Parte 2  
Part 2  
Teil 2  
Partie 2  
Part 2  
Μέρος 2  
Parte 2  
Deel 2  
Kısım 2

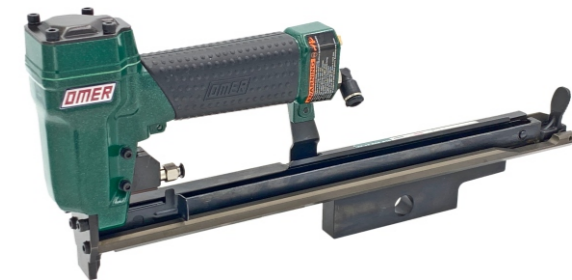

## 65.16 ROC-C72

cod. 11568ROC-C72

Dati tecnici Technical data Technische Daten	Caractéristiques techniques Datos técnicos Τεχνικά χαρακτηριστικά	Dados técnicos Technische gegevens Teknik veriler
<b>Misure impiegabili mm</b> Lengths mm Verwendbare Nagellänge mm	Dimensions utiles mm Medidas de longitud mm Μήκος Αναλωσίμου - mm	Medidas utilizáveis mm Toepasbare afmetingen mm Boy mm
<b>Capacità caricatore n° punti</b> Magazine capacity Magazinkapazität Nägel	Capacité chargeur n° de points Capacidad cargador n° puntos Δωνατοτητα γεμιστερα	Capacidade carregador n° pontos Capaciteit magazijn in aantal spijkers Dergi kapasitesi
<b>Pressione d'esercizio</b> Operating pressure Betriebsdruck	Pression d'exercice Presión de servicio Πίεση λειτουργίας	Pressão de serviço Werkdruk Çalışma basıncı
<b>Consumo aria litri/colpo</b> Air consumption litres/stroke Luftverbrauch Liter/Schuss	Consumation d'air litres/coup Consumo aire litros/golpe Κατανάλωση αέρα - λίτρα/βολή	Consumo ar litros/disparo Luchtverbruik liter/slag Litre/vuruş hava tüketimi
<b>Peso kg</b> Weight kg Gewicht kg	Poids kg Peso kg Βάρος - kg	Peso kg Gewicht in kg Ağırlık kg
<b>Dimensioni mm</b> Dimensions mm Abmessungen mm	Dimensions mm Dimensiones mm Διαστάσεις mm	Dimensões mm Afmetingen mm Boyutlar mm
<b>UNI EN 12549 :2009</b>	<b>UNI EN ISO 3746 :2011</b>	<b>UNI EN ISO 4871 :2009</b>
<b>Potenza sonora emessa</b> Sound power emitted Emittierte Schalleistung	Puissance sonore émise Potencia sonora emitida Εκπεμπόμενη ηχητική ισχύς	Potência sonora emitida Geëmitteerd geluidsvermogen Çıkan ses gücü (ses desibeli)

**Tipo di punto**  
Type of fastener  
Befestigungsmittel  
Type de rivet  
Τύπος αναλωσίμου  
Tipo de agrafa  
Type nietjes  
Zimba ve çivi tipleri

65

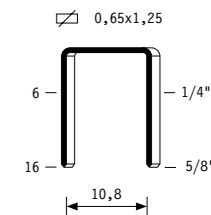

Gauge: 19  
Crown: .476" (1/2")

11568ROC-C72\_6516ROC-C72\_5\_rev20\_17/12/2020\_IV

**DO NOT  
HANDHELD  
THIS TOOL**



Parti di ricambio - Spare parts - Ersatzteile - Pièces de rechange - Recambios  
Ανταλλακτικά - Partes sobresselentes - Wisselstukken - Yedek parçalar

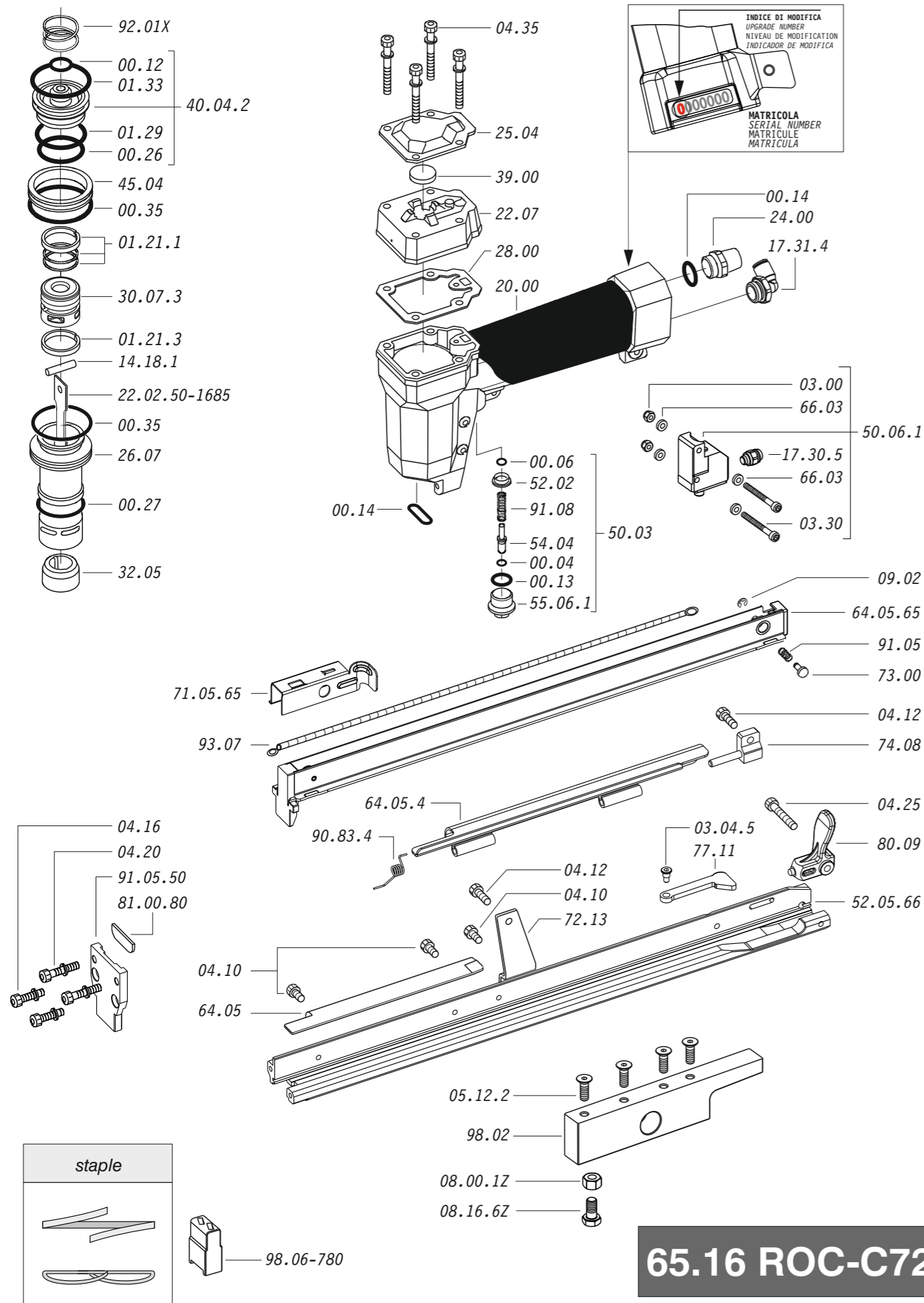

**65.16 ROC-C72**

cod. 11568ROC-C72

Parti di ricambio - Spare parts - Ersatzteile - Pièces de rechange - Recambios  
Ανταλλακτικά - Partes sobresselentes - Wisselstukken - Yedek parçalar

Cod.	Descrizione	Description
00.04	O-Ring	O-Ring
00.06	O-Ring	O-Ring
00.12	O-Ring	O-Ring
00.13	O-Ring	O-Ring
00.14	O-Ring	O-Ring
00.26	O-Ring	O-Ring
00.27	O-Ring	O-Ring
00.35	O-Ring	O-Ring
01.21.1	Guarnizione	Gasket
01.21.3	Guarnizione	Gasket
01.29	O-Ring	O-Ring
01.33	O-Ring	O-Ring
03.00	Dado	Nut
03.04.5	Vite	Screw
03.30	Vite	Screw
04.10	Vite	Screw
04.12	Vite	Screw
04.16	Vite	Screw
04.20	Vite	Screw
04.25	Vite	Screw
04.35	Vite	Screw
05.12.2	Vite	Screw
08.16.6Z	Vite	Screw
08.00.1Z	Dado	Nut
09.02	Anello elastico	Elastic ring
14.18.1	Spina	Pin
17.30.5	Attacco	Connection
17.31.4	Attacco	Connection
20.00	Corpo	Body
22.07	Testa	Head
24.00	Silenziatore	Silencer
25.04	Deflettore	Exhaust deflector
26.07	Cilindro	Cylinder
28.00	Guarnizione	Gasket
30.07.3	Pistone	Piston
32.05	Ammortizzatore	Bumper
39.00	Guarnizione scarico	Exhaust gasket
40.04.2	Valvola completa	Valve ass'y
45.04	Anello valvola	Ring
50.03	Pulsante completo	Trigger valve ass'y
50.06.1	Comando a distanza	Remote control trigger
52.02	Boccola	Bush
54.04	Pulsante	Trigger valve
55.06.1	Raccordo	Bush
64.05	Carter	Hold down
64.05.4	Carter mobile	Hold down
66.03	Rondella	Washer
77.11	Leva	Lever
72.13	Reggicaricatore	Support
73.00	Perno	Pin
74.08	Staffa	Support
80.09	Grilletto chiusura	Trigger
91.05	Molla	Spring
91.08	Molla	Spring
90.83.4	Molla	Spring
92.01X	Molla	Spring
93.07	Molla	Spring
98.02	Cerniera	Hinge
98.06-780	Incidine	Anvil
22.02.50-1685	Battente	Driver
52.05.66	Caricatore	Magazine
64.05.65	Carrello	Slider
71.05.65	Spingipunto	Pusher
81.00.80	Controtestina	Nose
91.05.50	Testina	Nose plate

**65.16 ROC-C72**

cod. 11568ROC-C72

Guarnizioni - O-Rings - Dichtungen - Juntas - Δακτύλιος στεγανοποίησης - Vedantes - O-ringen - Contalar

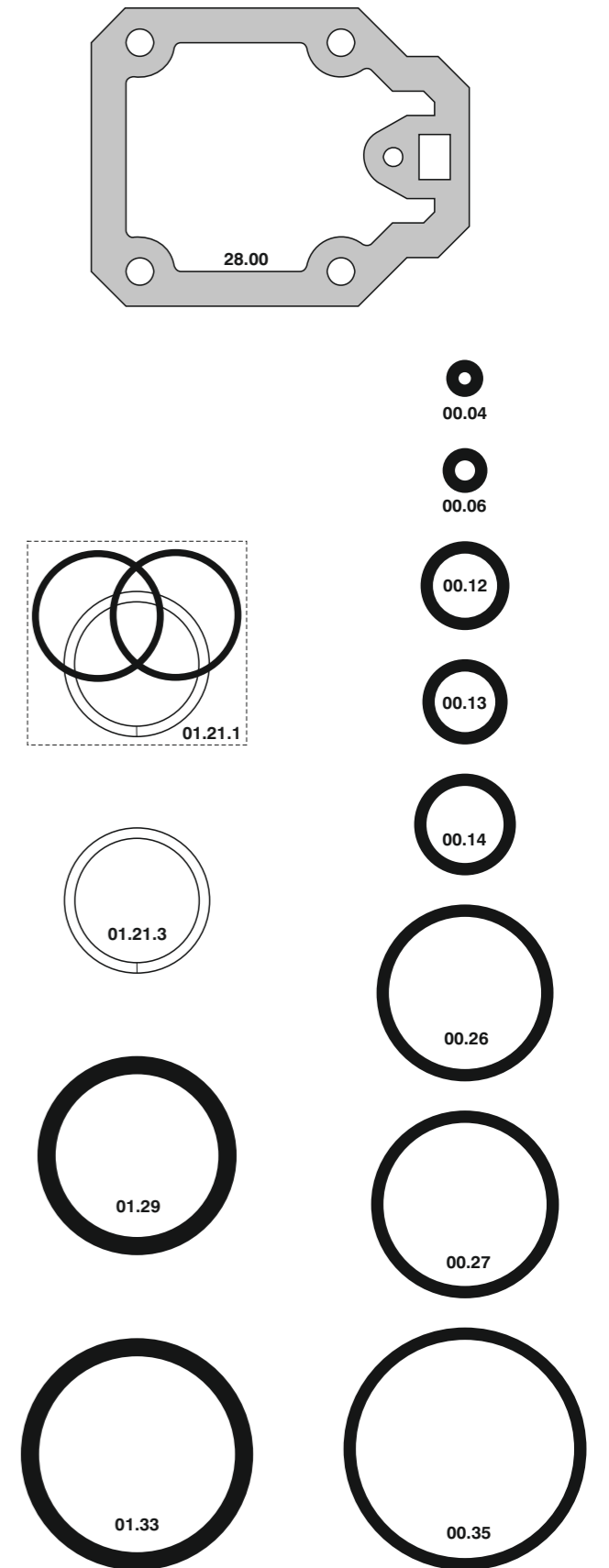

Indice di modifica  
Upgrade number

**5**