

# 65.16 ROP-4

cod. 11568ROP-4

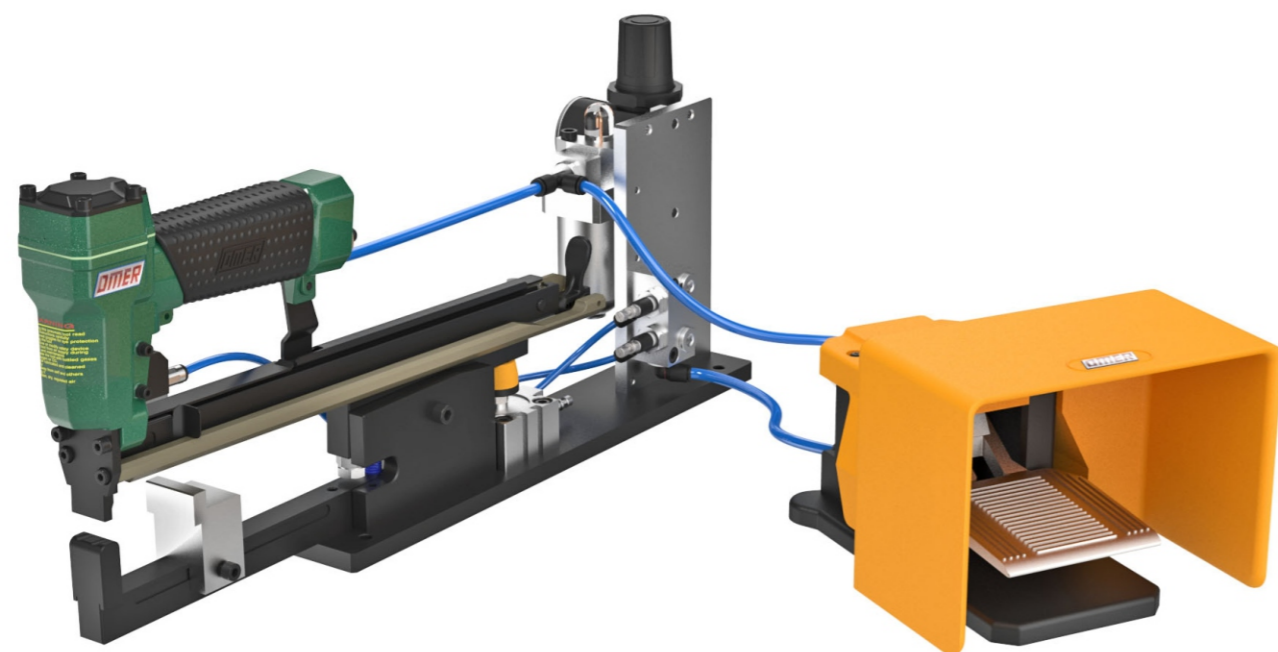

## INTRODUCTION:

The bench-mounted stapler ROP is the optimal solution for fixing blisters, paper or plastic bags, boxes, displaying cards, etc.

### Features:

- Possibility to be easily fixed upon working surface
- Pneumatic system complete with FRL unit & manometer for a correct power supply
- Pedal activated mode
- Working pressure: 5,5 ÷ 6,5 bar (80 ÷ 95 psi)
- Top loading
- Magazine capacity: 2 strips
- Applicable sizes: 6 to 16mm
- Easy jam-clearing
- Easily replaceable pneumatic tool units (with units suitable for different fastener series, i.e. 3G, 64, 80, 50, 65, 40, 4097)
- Possible adjustments:
  - Clinching depth
  - Front side opening
  - Clinching speed
  - Fire delay

**DO NOT  
HANDHELD  
THIS TOOL**

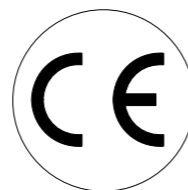

**USE MANUAL and SPARE PARTS**

**IMPORTANT DO NOT DESTROY !**

*Read carefully this manual before using the tool and respect the security norms herewith enclosed.*

11568ROP-4\_6516ROP-4\_5 010621 IV

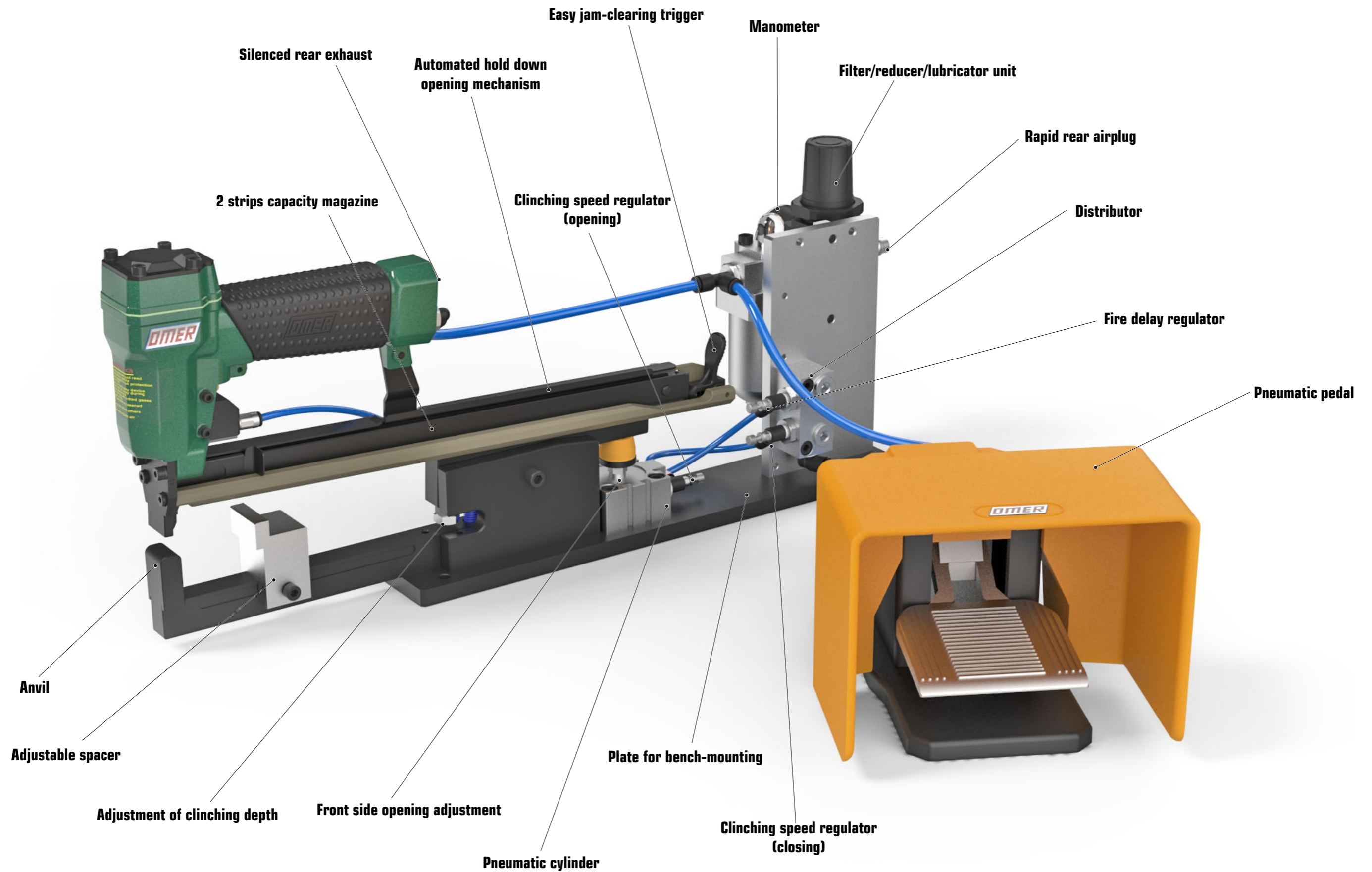

# INDEX:

Introduction .....	1
Nomenclature .....	2 - 3
Index .....	4
Declaration of conformity .....	5
User Manual and security norms .....	5 - 7
Warranty .....	7
Technical data .....	8 - 9
Operating mode .....	10
Settings ( to be performed in sequence):	
- Front side opening .....	11
- Clinching depth .....	12
- Clinching speed .....	13
- Firing .....	13
Loading .....	14
Jam-clearing .....	15
Spare parts .....	16
Spare parts for 65.16 ROC-C4 stapler .....	17
Spare parts for 65.16 ROP-4 .....	18
Pneumatic diagram .....	19
Accessories – O-Rings .....	20
Spare parts list .....	21
Notes .....	22

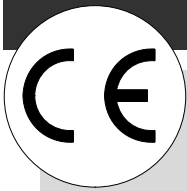

# Conformity declaration

(Conformity to annex II part 1 section A of Directive 2006/42/EC.)

OMER, having registered offices in Via Foresto, 42 - I-31058 ITALIA hereby declares under its own responsibility that the pneumatic stapler to which this booklet refers, and whose model, serial number and year of manufacture are printed on the cover, complies with the essential safety requisites established in the 2006/42/EC and meets the requirements of standard UNI EN 792-13:2009.

Susegana 25-01-2010

The duly authorised representative

## INSTRUCTION MANUAL

### FOREWORD

This Instruction Manual and the attached Data Sheet (which forms an integral part of it) have both been drawn up in conformity with EEC guideline 2006/42/EC. Both publications are meant for the user of the tacker and contain information on the use of the machine as intended by the manufacturer; they also supply the necessary technical data for its correct use and the safety rules to be strictly observed by the user of the stapler. The instruction manual is to be considered an integral part of the gun and must be kept in a safe place for future reference for the entire life of the machine.

### INTRODUCTION

In order to assure high reliability, OMER has made a careful choice of the materials and components to be used in the manufacturing process of the tool and has tested it before delivery. Proper performance of the tacker in time also depends on its correct use and on adequate servicing according to the instructions contained in this manual. All of its components, connecting parts and control devices have been designed and implemented with built-in safety to enable them to withstand even unusual stresses, in excess of those set in this manual. The best quality materials have been used and they have been accurately tested on arrival, during storage and while being processed in the workshop for damage, wear or malfunctioning.

**The following should be remembered at all times:**

- 1) Do not use or service the machine before reading and clearly understanding this Manual and the attached Data Sheet in all their parts.**
- 2) In particular, take all the precautions listed in section A - Safety prescriptions and information.**
- 3) Never use the machine under different conditions or for a different purpose than stated in the manual. OMER spa cannot be held responsible for faults, breakdowns or damage due to failure to observe these rules.**

### Section A

#### General information for a safe use of the stapler

#### A.1 - Working conditions as prescribed by the manufacturer

The stapler must be well fixed onto a working surface. A compressed air supply system corresponding to the requisites described in section B of this manual must be used. The working pressure must be the one mentioned under TECHNICAL DATA of this manual. The stapler has been designed for clinching metal fasteners on soft materials (paper, cardboard, PVC, plywood, etc.) and it cannot be used on other hard materials such as cement, metals, tiles, etc.). It is always necessary to take all precautions to reduce risks of injury to the operator or to other persons in the working area:

- protect your eyes from dust or danger represented by metal fasteners by using approved safety glasses;
- avoid ear injuries by using head sets.

#### A.2 - Safety measures

Never forget that the stapler can be dangerous, so never play about with it. Do not press the control trigger when connecting the nailing machine to the compressed air supply. Do not remove, lock or misuse the safety catch in any way. Do not allow children or unskilled persons to handle the gun. Never connect the tacker to other power sources than compressed air. High-pressure gas (propane, acetylene, oxygen, etc.) is highly dangerous and may cause the gun to explode. Never use the stapler on any other purpose than the one it was meant for. Never use the tool next to volatile flammable material such as petrol, solvents, paints or gas. Never supply air to the tacker at a different pressure than indicated in the table on the Data Sheet. Never drive staples or nails on top of earlier ones. Do not staple too close to the edge of the object: dangerous chips might fly off. Do not replace the original service coupling with others which might retain compressed air within the gun after it has been disconnected from the air.

#### A.3 - Disconnection from the supply

The machine must be disconnected from the compressed air supply system when:

- the machine is not in use.
- you must leave your working area unguarded, even just for a few minutes.
- the stapler is jammed;
- the stapler needs to undergo servicing or repairs.

## Section B

### Compressed air supply system

#### B.1 Foreword

Peak performance of the staplers and the length of their useful life depend chiefly on the compressed air supply system: a properly sized system built of quality components and subjected to regular maintenance assures the best performance of the connected pneumatic staplers.

#### B.2 - Design of the compressed air system

The system must take into account the following factors:

- ◆ The power of the air compressor must meet requirements both with regard to pressure and to the air flow supplied. It should be remembered that a pressure drop takes place along the line due to load losses through chokes, outlets, etc.;
- ◆ the main service line must be of adequate size to cope with the type and number of users connected. Whenever possible, avoid using chokes, elbows or any other means to break the flow which might contribute to pressure drops along the line. The latter must be slightly inclined to drain off any condensation which unavoidably forms;
- ◆ the branch pipe with cock and steam trap must be shaped in such a way as to hinder the passage of condensation from the service line;
- ◆ the regulator unit with cock consists of a combination of filter-steam trap, a pressure regulator with pressure gauge and a microspray lubricator;

**NOTE: To execute the connection to the compressed air mains, so-called quick-connect couplers are used, in which the male adapter must be mounted on the stapler in such a way that no compressed air remains in it after it has been disconnected from the mains.**

#### B.3 - Servicing

Check regularly the pressure regulator unit and the oil pressure level in the lubricator for proper operation; if necessary, top up with oil for pneumatic tools. Proper tacker operation largely depends on moving parts being constantly lubricated, which only the microspray lubricator can assure. Drain off the condensation regularly (daily) from the lines and the filter-trap, since it damages the tacker. Clean the regulator unit filter weekly.

## Section C

### Information on the use of the stapler

#### C.1 - Tacker performance

It is important that the machine be used only for the purpose for which it was designed and that it not be tampered with in any way. Before starting to use it, always make sure there is no air leakage, that all parts work properly and especially that the safety system is perfectly efficient. Also make sure that the machine is clean and lubricated.

#### C.2 - Working pressure

The tacker must always be supplied at a pressure within the range indicated on the Data Sheet table. A higher pressure than the one suggested by the manufacturer increases the stress to which it is subjected and therefore the wear of some of the components. If on the other hand the pressure used is lower than shown on the table, proper performance cannot be assured. For proper performance and long life, the working pressure of the gun must always be the lowest possible required to assure full penetration of the staple or of the nail; therefore, if after shooting the fastener has not penetrated completely, increase the pressure by 0.5 bar at a time, checking the effect. If the penetration is excessive, reduce the pressure by 0.5 bar at a time until the required degree of penetration is achieved. It is strictly forbidden to supply the gun with high-pressure gas such as oxygen, carbon anhydride or other bottled gases: the gun might explode and cause serious damage and injury.

#### C.3 - Trigger and safety catch

These are highly important parts from a safety point of view and must therefore always be perfectly efficient. The safety catch must never be tampered with, removed or blocked in such a way as to void the purpose for which it was designed.

#### C.4 - Loading the tool

It is a safe practice to disconnect the gun from the compressed air line before loading it to rule out any cause for accidents. If the gun is not disconnected from the mains, take the utmost care in handling it since this may cause highly dangerous accidental shooting.

#### C.5 - Jam-clearing

If the gun jams, disconnect the gun from the compressed air line and unload the magazine, clean the head, the magazine and any other parts connected with it. If jamming occurs too often, consult a specialized service centre.

**NOTE: In order to avoid jamming, breakage or early wear, only use staples or nails of the type indicated for each model. OMER staples and nails are of a size and quality that make them ideal for staplers and therefore assure top performance at all times and long life. OMER spa does not answer for damage to the gun due to the use of staples or nails of types not suitable for the model.**

## Section D

### Information regarding maintenance and repair

#### D.1 - Maintenance instructions

In order to assure the safety and reliability of OMER guns, maintenance and repairs must be carried out by skilled persons and OMER original spare parts must always be used. If you notice any irregularities in the operation of the machine, stop work at once, disconnect it straight away from the compressed air supply and unload the magazine. Do not reconnect the machine to the compressed air line before it is in a perfect state of repair.

#### D.2 - Routine servicing

Before connecting the gun to the compressed air system, always check that the trigger and safety catch are perfectly efficient. Never use the machine unless these safety arrangements work to perfection.

If a microspray lubricator on line with the system is not available, add a few drops of special oil for pneumatic tools through the air supply coupling. Never use gasoline, kerosene or detergent oils.

Before starting to work, check the gun for perfect tightness to pressure. If any leakage is noticed, the machine must be checked thoroughly before use.

Every day, after completing work, clean out the magazine with an air jet, all moving parts and any points in the gun where dirt may settle. Do not clean the gun with solvents, as this might damage the paint and some internal parts; do not submerge it in water or other liquids.

#### D.3 - Inspections and repairs

Inspect the inside of the gun regularly to check the state of repair of parts subject to wear.

To do so, unscrew the head screws with the hex spanner supplied, open the gun and remove the different components.

Check carefully the state of wear of the O-rings and of the rubber parts. Replace the worn parts with OMER original spare parts. Lubricate the O-rings and moving parts with a fine film of special grease for pneumatic tools. Wash the bronze silencer - if provided - by dipping it into a solvent for a few minutes and then blasting it dry with a jet of compressed air.

Check the state of the shock absorber: if it shows signs of wear or failure, it needs replacing. This is very important for the safety of the gun and therefore for operator protection as well. Finally check the state of wear of the end of the back plate. If it is replaced and is of the threaded type, screw the replacement onto the piston using a medium strong thread braking liquid. On some models there is a servovalve inside the head, fitted in its seat; if you need to remove it, check the position of the reference notches cut in the brass bush and the head. When you put back the servovalve bush, make sure that its notch is aligned with the one grooved into the head. Never wash the O-rings and other rubber parts with solvents, gasoline, kerosene, etc.

## GUARANTEE

**OMER spa** undertakes to replace free of charge any parts which its engineers acknowledge to be faulty due to manufacturing or material defects, during the life of the machine. The guarantee does not cover any components subject to normal wear and tear during operation (shock absorber, back plate, etc.). This guarantee is void if malfunction or breakage are due not to manufacturing faults but to an improper use of the tool, not in conformity with the manufacturer's instructions. Freight charges are always at the buyer's expense.

## Suitable staple series :

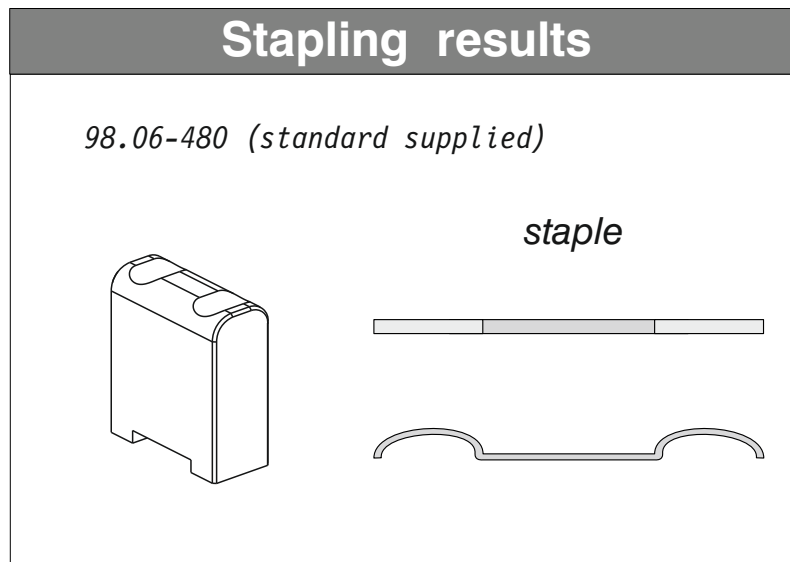
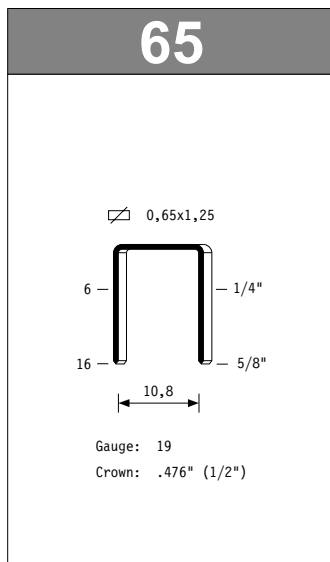
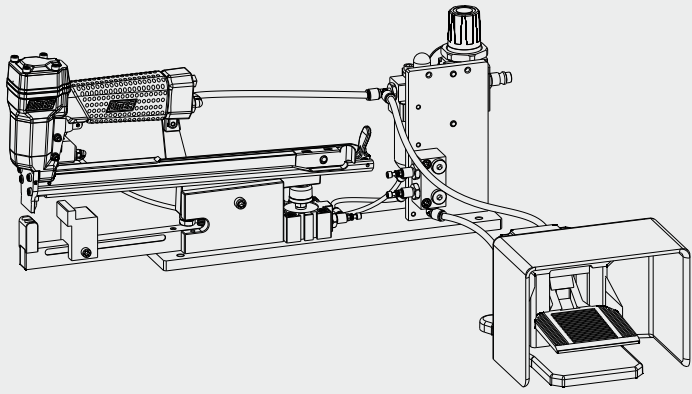
<b>Usable lengths mm</b>	<b>8 ÷ 16</b>
Usable lengths inch	<i>5/16" ÷ 5/8"</i>
<b>Magazine capacity No. of fasteners</b>	<b>220</b>
<b>Working pressure bar</b>	<b>5,5÷6,5</b>
Working pressure psi	<i>80 ÷ 95</i>
<b>Air consumption litres/shot</b>	<b>0,58</b>
Air consumption ft <sup>3</sup> /shot	<i>0,0204</i>
<b>Weight kg</b>	<b>7,0</b>
Weight lbs	<i>15,43</i>
<b>Sound pressure at the workstation</b>	<b>75 dB(A)</b>
<b>Emitted sound power</b>	<b>80 dB(A)</b>

# Technical data

\*all sizes are shown in mm

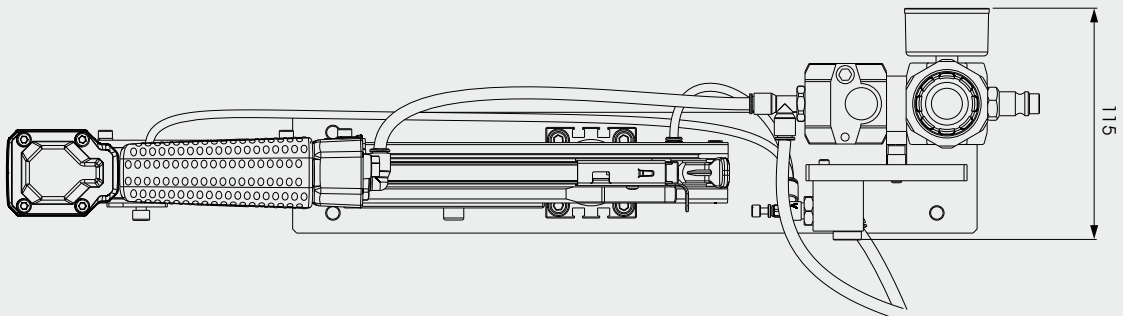
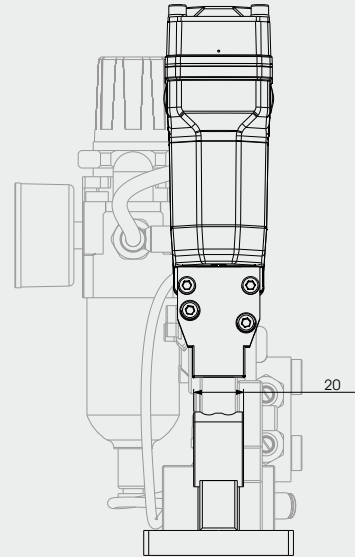
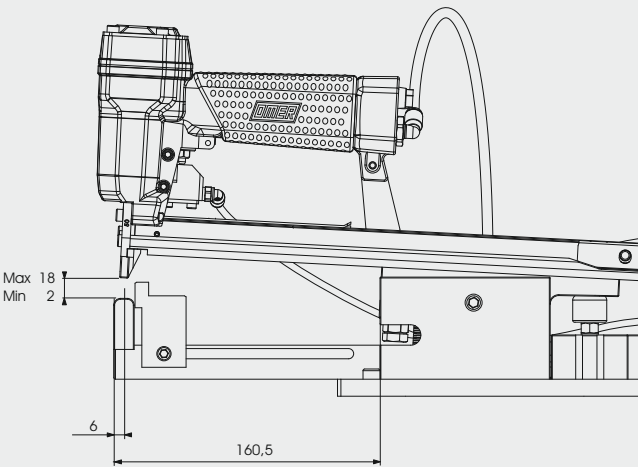
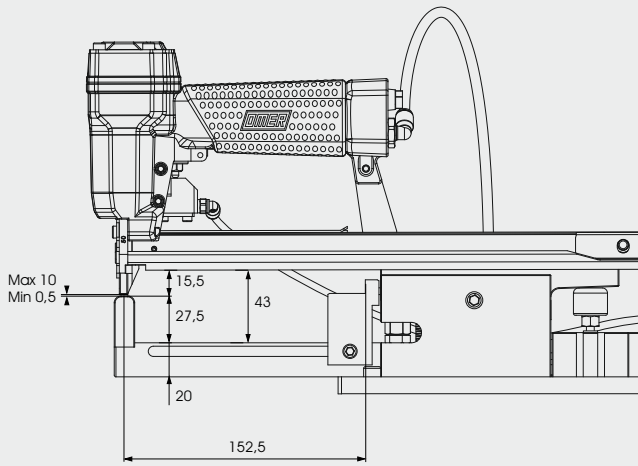

523

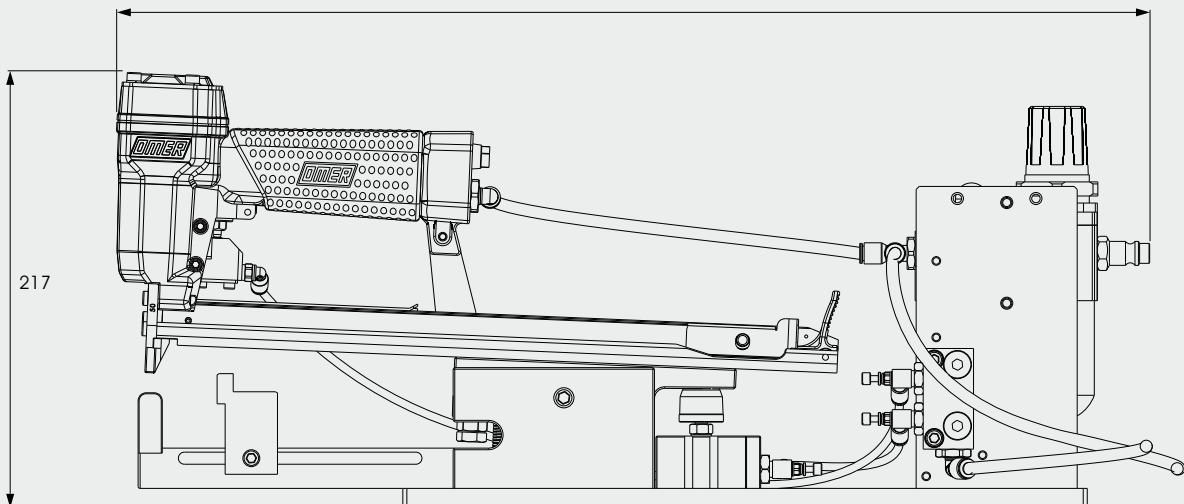



## Operating mode

### Tool operating :

- 1 - Insert the material to be fastened until spacer is met.
- 2 - Press pedal to activate the stapler.



Before using the unit make sure all necessary adjustments for a correct and safe usage have been performed.

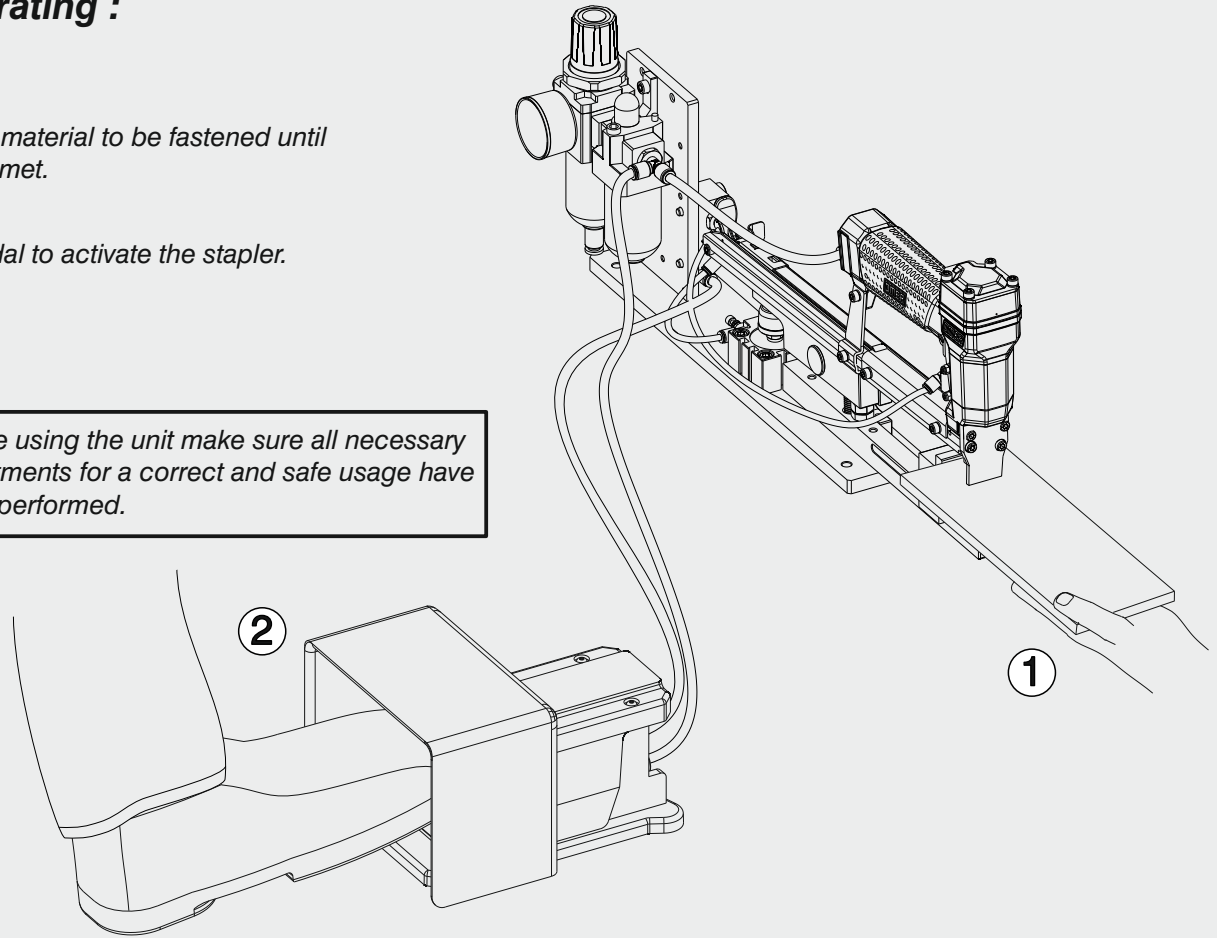

## Setting of staple position

The stapling position is determined by adjusting the spacer as follows:

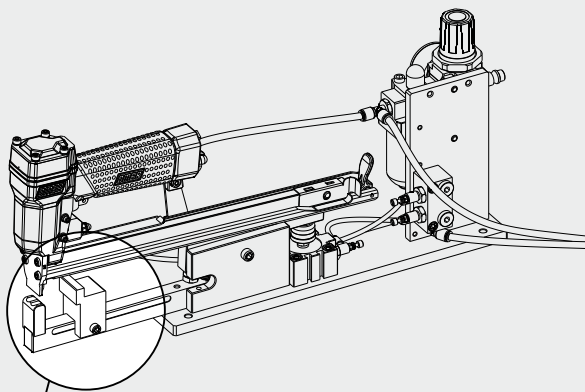

- 1 - Loosen the screws.
- 2 - Slide the spacer along the guide until required position.
- 3 - Tighten the screws.
- 4 - When necessary, invert the spacer to gain maximum distance.

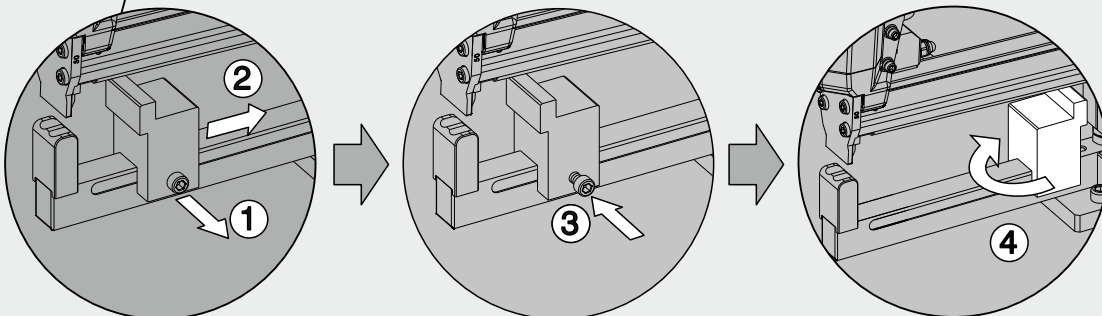

# Adjustment of front side opening

*A front side opening adjustment must be carried out to allow an easy insertion of the material to be fastened.*

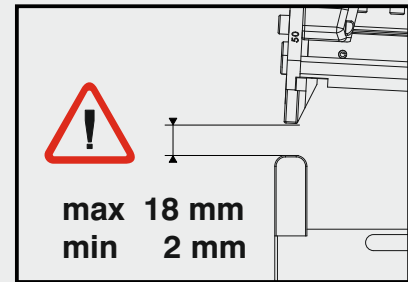
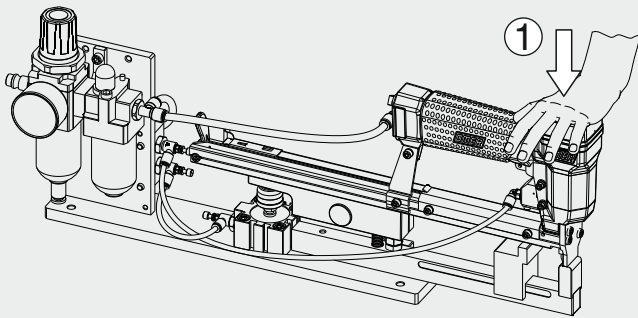

*1 - Press the stapler head and keep this position to gain access to the pneumatic cylinder and bumper.*

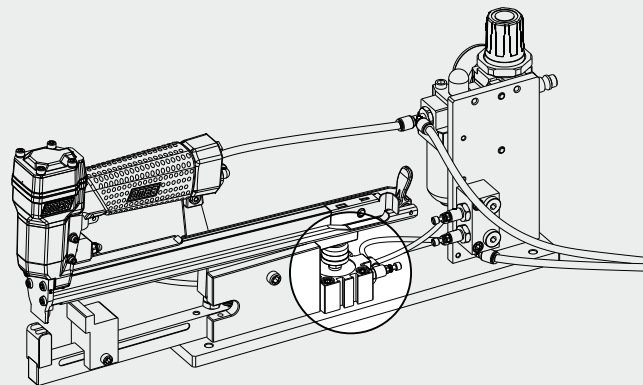
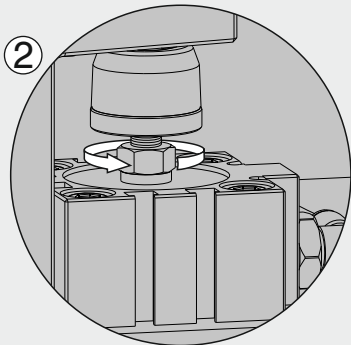
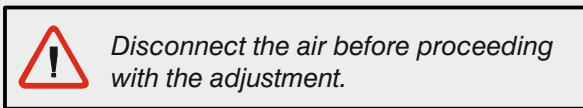

*2 - Loosen the nut.*

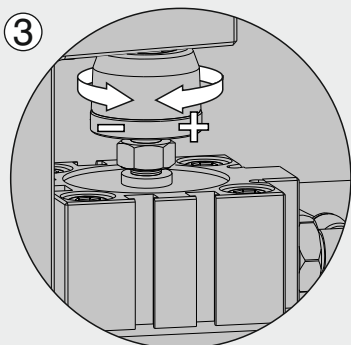

*3 - Screw/unscrew the bumper to increase/decrease the opening*

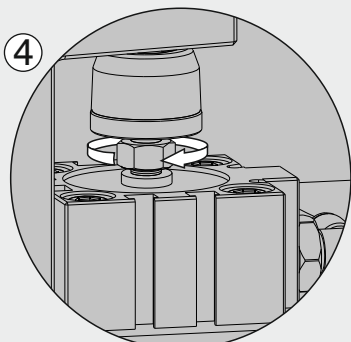
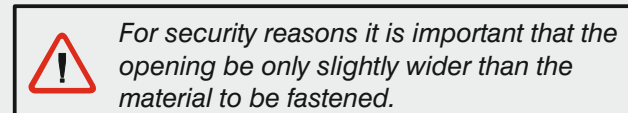

*4 - Tighten the nut.*

# Clinching depth adjustment

To avoid flattening/damaging the material to be fastened it is possible to set the clinching depth by adjusting the end-run screw.

 Disconnect the air before proceeding with the adjustment.

  
max 10 mm  
min 0,5 mm

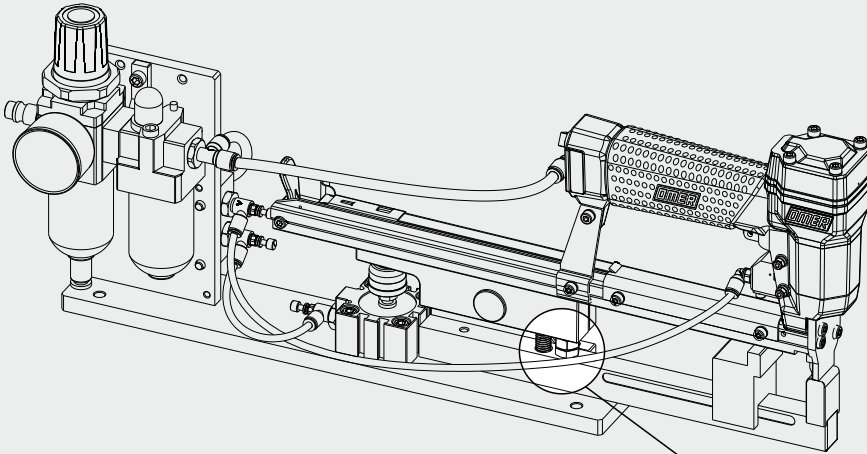

1 - Loosen the nut which stops the end-run screw.

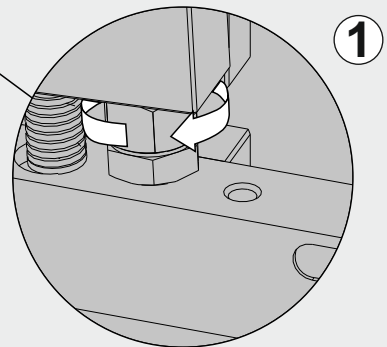

2 - Screw or unscrew the end-run screw to adjust the clinching depth.

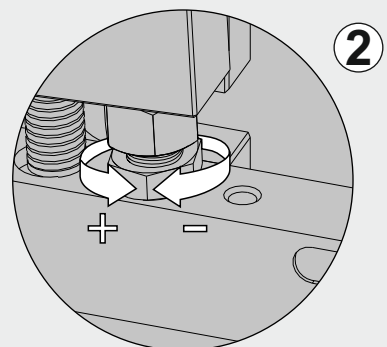
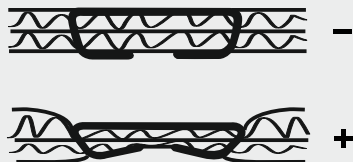

3 - Tighten the locking nut.

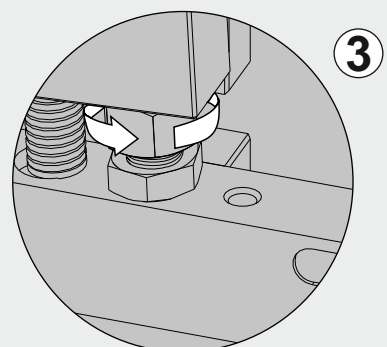

## Fire delay adjustment

*Fire delay adjustment is the more necessary the wider is the front opening on the tool, since you must give time to the stapler to block the material before firing.*

- +** *delays firing*
- *anticipates firing*

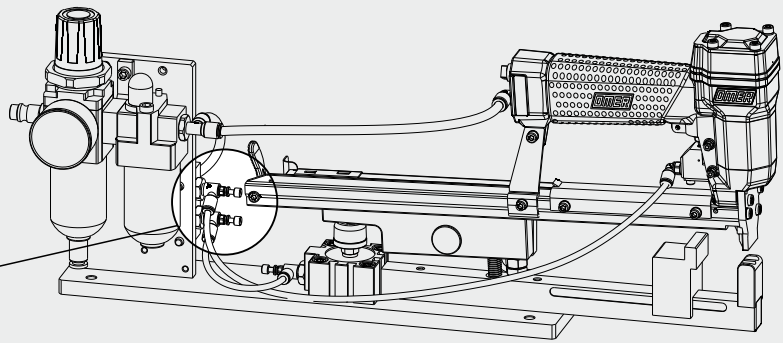
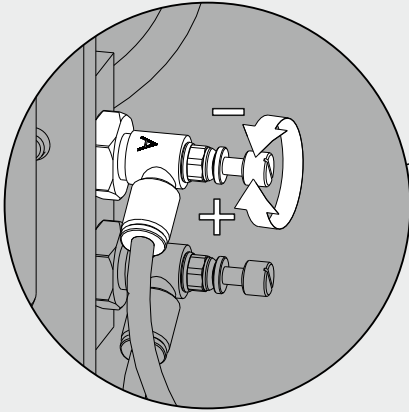

## Clinching speed adjustment

*This adjustment allows you to set the most comfortable working speed. An excess of speed - identifiable in too sudden movements of the stapler - may lead to premature tool wear-out.*

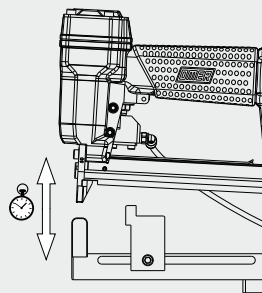
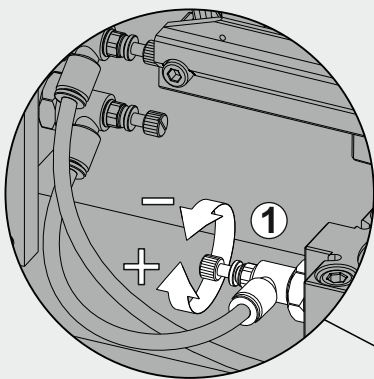

- ①** **+** *increases closing speed*
- ①** **-** *decreases closing speed*
- ②** **+** *increases opening speed*
- ②** **-** *decreases opening speed*

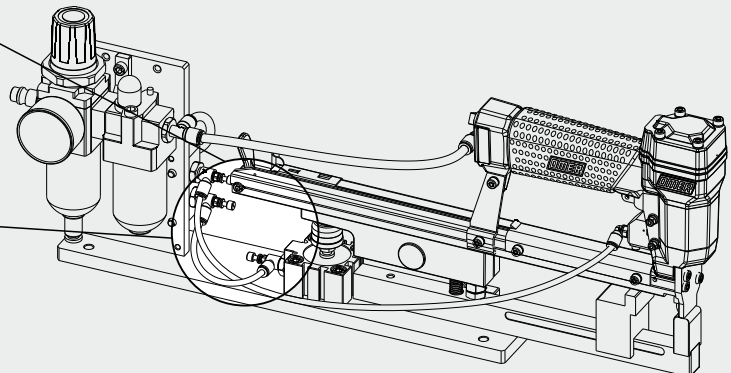
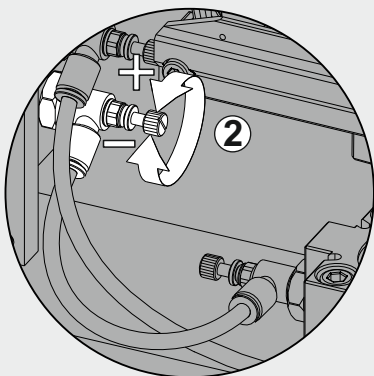

# Loading



*DO NOT press pedal while loading, to avoid activating the device*

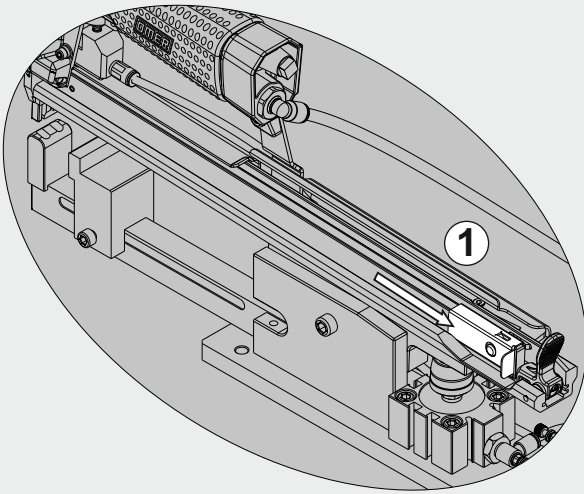

*1 - Pull the pusher backwards and lock it at the stop position at the rear of the tool, this will open the movable hold down*

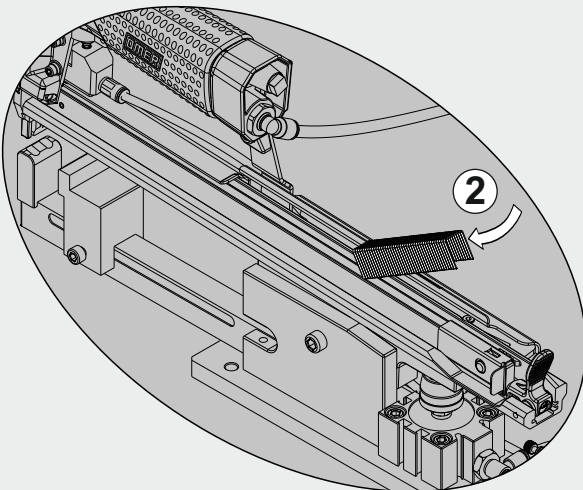

*2 - Load staples*

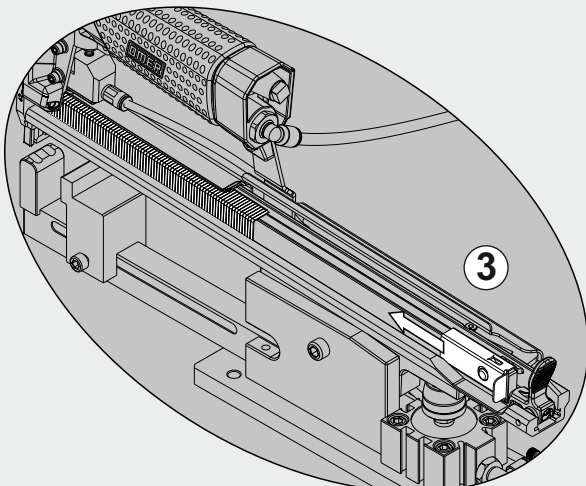

*3 - Release the slider*

# Jam-clearing

*In case of jamming, proceed as follows:*

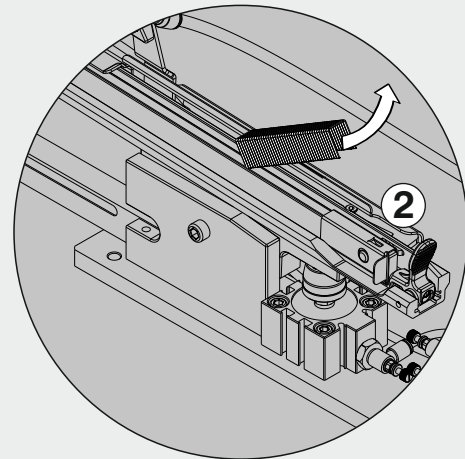
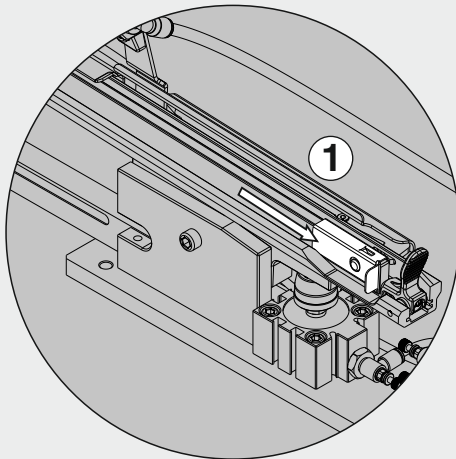

*1 - Pull the pusher all the way back and lock it.*

*2 - Remove the staples from the magazine.*

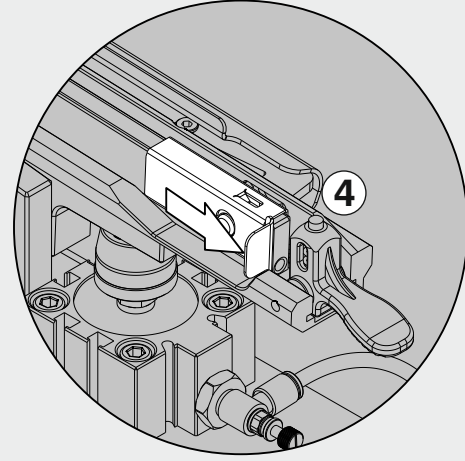
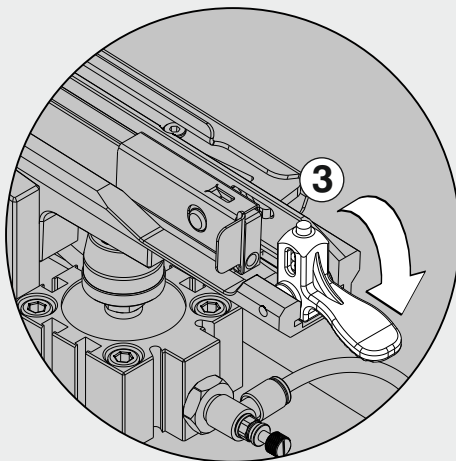

*3 - Open the slider closing trigger.*

*4 - Pull the slider all the way back by acting on the pusher and holding it in such a position.*

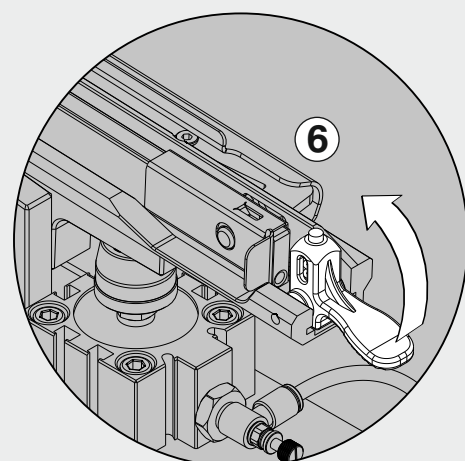
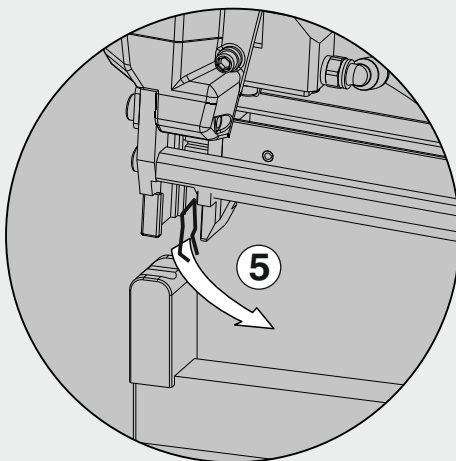

*5 - Pull the jammed staple out from the firing channel.*

*6 - Release the slider and block closing trigger.*

*7 - Load the tool regularly.*

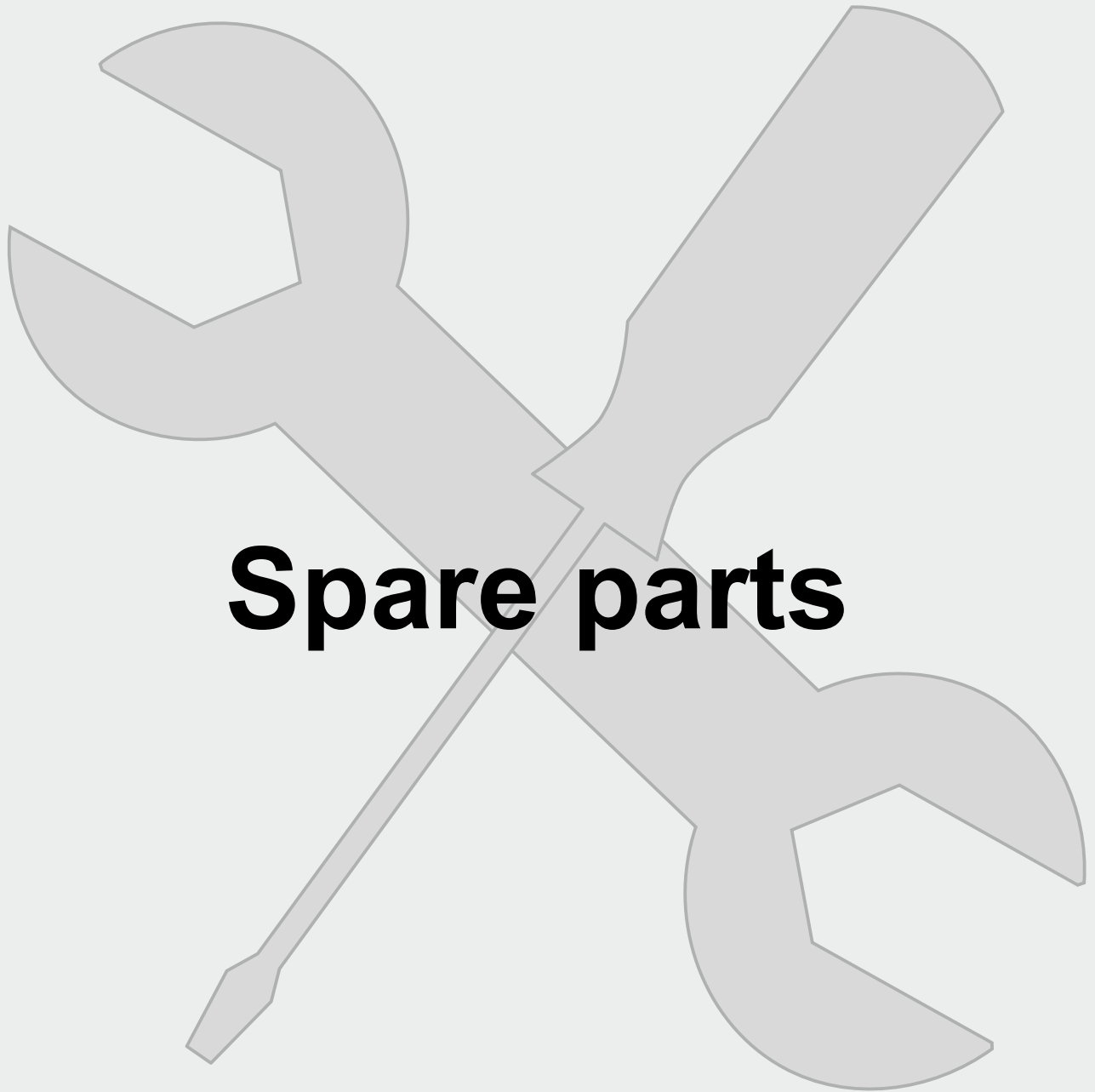

# **Spare parts**

# Spare parts

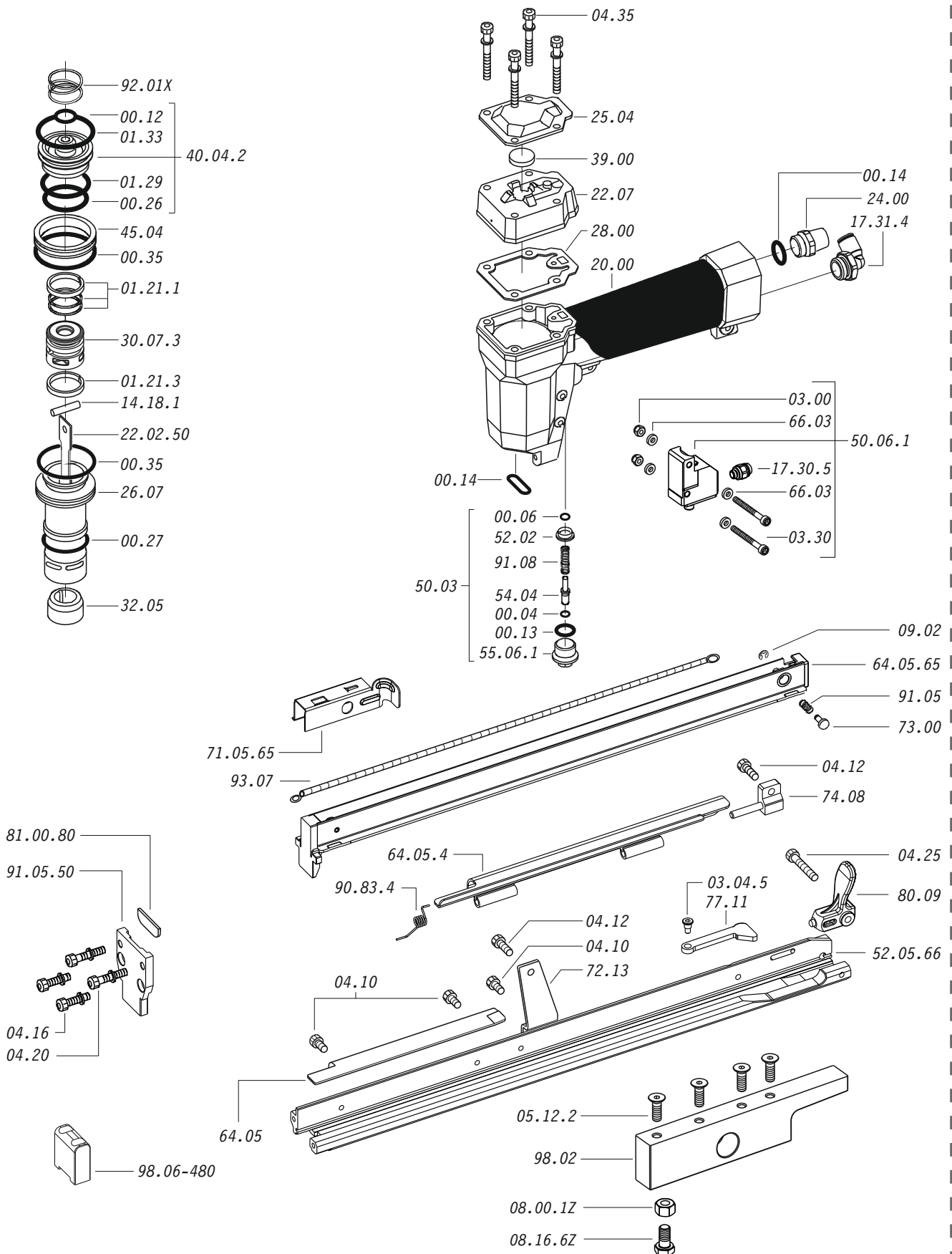

**65.16 ROC-C4**

cod. 21568ROC-C4

**65.16 ROP-4**

cod. 11568ROP-4

Upgrade  
Number

**5**



# Spare parts

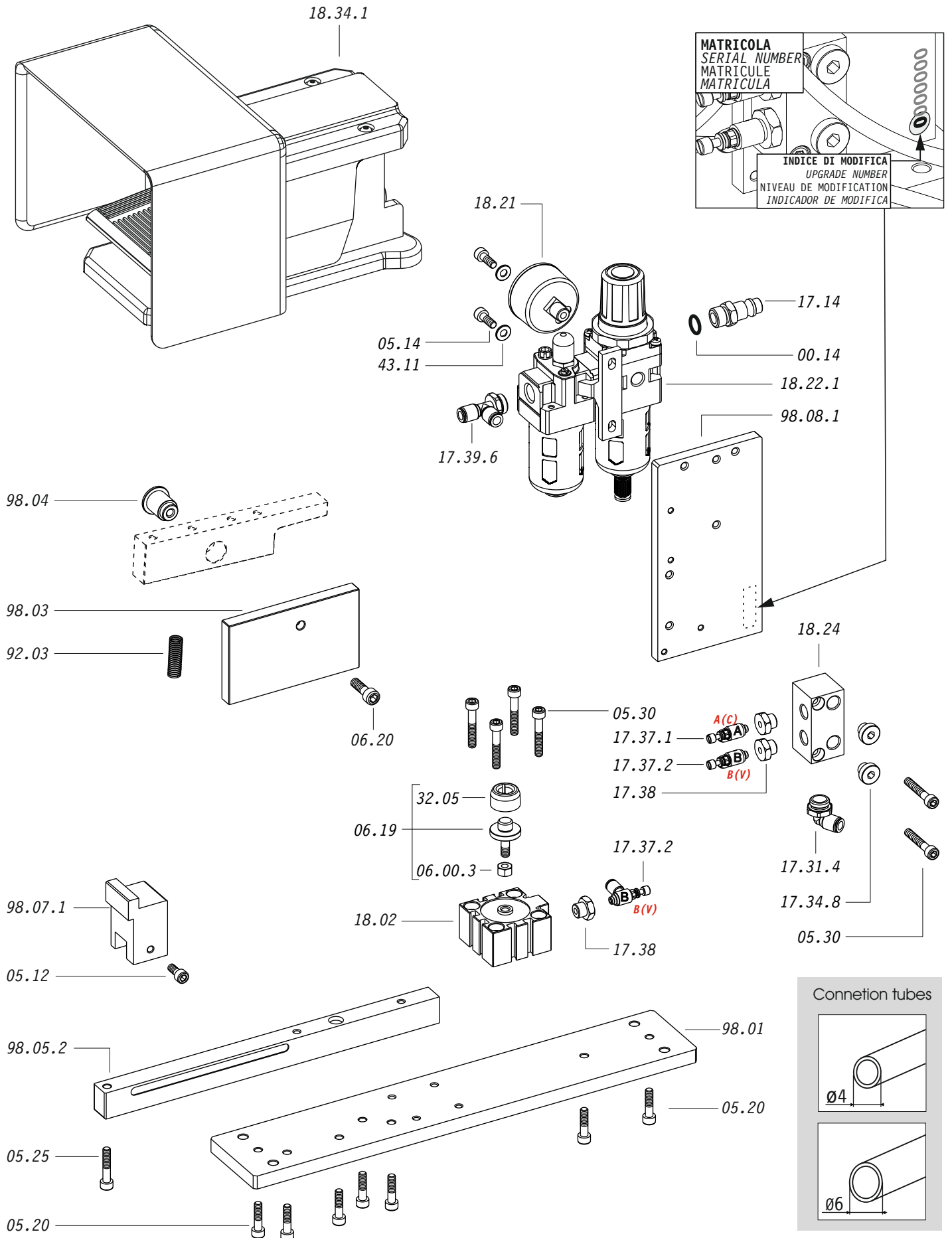

65.16 ROP-4

cod. 11568ROP-4

Upgrade  
Number

5

# Pneumatic diagram

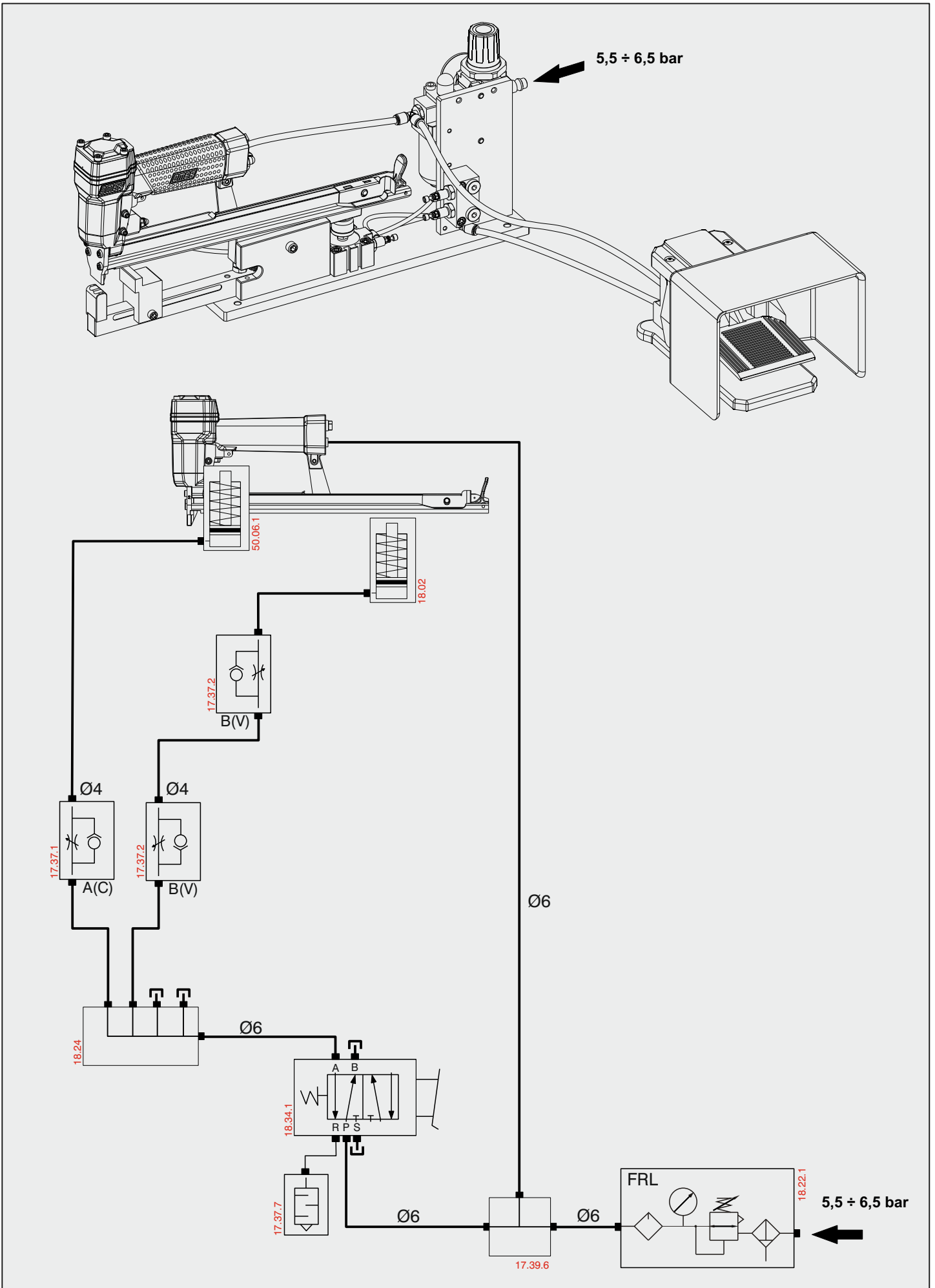

## Accessories

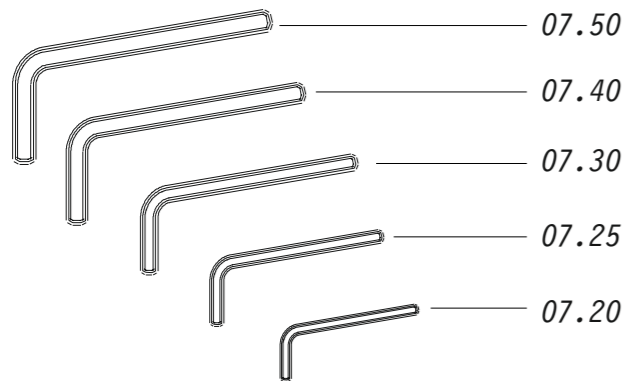
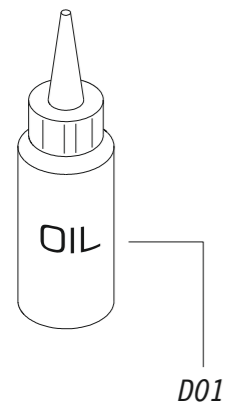

## Available anvil

98.06 (on request)

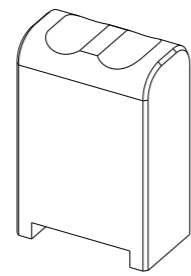

staple

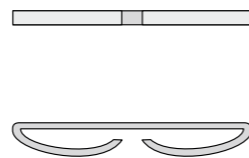

## O-Ring

00.70.5

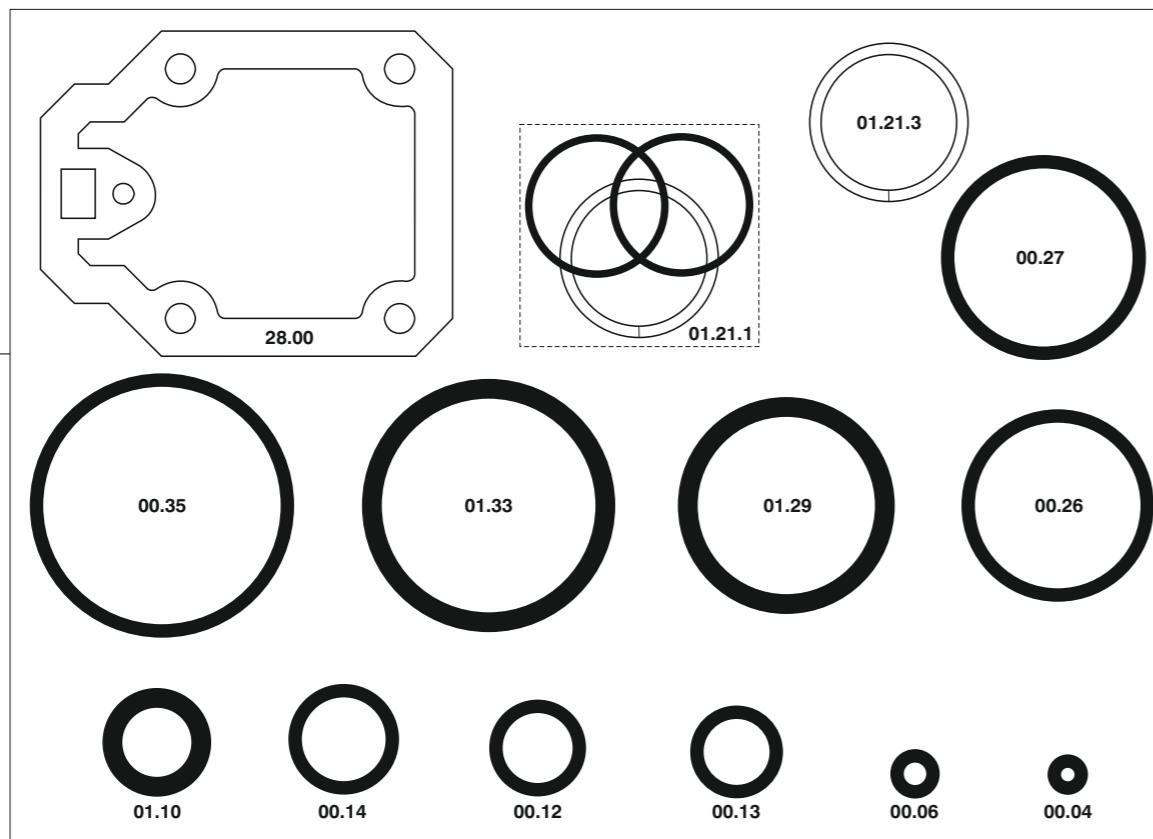

## Spare parts list

Cod.	Descrizione	Description	Cod.	Descrizione	Description
00.04	O-Ring	O-Ring	18.22.1	Filtro riduttore lubrificatore	Reducer group
00.06	O-Ring	O-Ring	18.24	Distributore	Distributor
00.12	O-Ring	O-Ring	18.34.1	Pedale Pneumatico	Pneumatic Foot Lever
00.13	O-Ring	O-Ring	20.00	Corpo	Body
00.14	O-Ring	O-Ring	22.07	Testa	Head
00.26	O-Ring	O-Ring	24.00	Silenziatore	Silencer
00.27	O-Ring	O-Ring	25.04	Deflettore	Exhaust deflector
00.35	O-Ring	O-Ring	26.07	Cilindro	Cylinder
01.21.1	Guarnizione	Gasket	28.00	Guarnizione	Gasket
01.21.3	Guarnizione	Gasket	30.07.3	Pistone	Piston
01.29	O-Ring	O-Ring	32.05	Ammortizzatore	Bumper
01.33	O-Ring	O-Ring	39.00	Guarnizione scarico	Exhaust gasket
03.00	Dado	Nut	40.04.2	Valvola completa	Valve ass'y
03.04.5	Vite	Screw	43.11	Rondella	Washer
03.30	Vite	Screw	45.04	Anello valvola	Ring
04.10	Vite	Screw	52.02	Boccola	Bush
04.12	Vite	Screw	50.03	Pulsante Completo	Trigger Valve ass'y
04.16	Vite	Screw	50.06.1	Comando a distanza	Remote control ass'y
04.20	Vite	Screw	54.04	Pulsante	Trigger Valve
04.25	Vite	Screw	55.06.1	Raccordo	Bush
04.35	Vite	Screw	64.05	Carter	Hold down
05.12	Vite	Screw	64.05.4	Carter mobile	Hold down
05.12.2	Vite	Screw	66.03	Rondella	Washer
05.14	Vite	Screw	72.13	Reggicaricatore	Support
05.20	Vite	Screw	73.00	Perno	Pin
05.25	Vite	Screw	74.08	Staffa	Support
05.30	Vite	Screw	77.11	Leva	Lever
06.00.3	Dado	Nut	80.09	Grilletto chiusura	Trigger
06.19	Gruppo ammortizzatore	Bumper ass'y	90.83.4	Molla	Spring
06.20	Vite	Screw	91.05	Molla	Spring
08.00.1Z	Dado	Nut	91.08	Molla	Spring
08.16Z	Vite	Screw	92.01X	Molla	Spring
08.16.6Z	Vite	Screw	92.03	Molla	Spring
07.20	Chiave esagonale	Hex. bar wrench	93.07	Molla	Spring
07.25	Chiave esagonale	Hex. bar wrench	98.01	Piasta Base	Base Plate
07.30	Chiave esagonale	Hex. bar wrench	98.02	Cerniera	Hinge
07.40	Chiave esagonale	Hex. bar wrench	98.03	Supporto	Support
07.50	Chiave esagonale	Hex. bar wrench	98.04	Perno	Pin
09.02	Anello elastico	Elastic ring	98.05.2	Traversa	Staff
14.18.1	Spina	Pin	98.06	Incudine	Anvil
17.14	Attacco Rapido	Air Plug	98.07.1	Distanziatore	Spacer
17.30.5	Racc. "L" 4 - M5	Conn. "Elbow" 4 - M5	98.08.1	Supporto	Support
17.31.4	Racc. "L" 6 - G1/4	Conn. "Elbow" 6 - G1/4	22.02.50-1685	Battente	Driver
17.34.8	Tappo	Cap	52.05.66	Caricatore	Magazine
17.37.1	Regolatore (A)(C)	Regulator (A)(C)	63.05.80	Carrello	Slider
17.37.2	Regolatore (B)(V)	Regulator (B)(V)	71.05.80	Spingipunto	Pusher
17.38	Riduzione	Reduction	81.00.80	Controtestina	Nose
17.39.6	Raccordo T	Tee connection	91.05.50	Testina	Nose plate
18.02	Cilindro Pneumatico	Pneumatic Cylinder	D01	Bocchetta olio	Oiler
18.21	Manometro	Manometer			

65.16 ROP-4

cod. 11568ROP-4

Upgrade Number **5**

65.16 ROP-4

cod. 11568ROP-4

Upgrade Number **5**

# Notes

