

# Caratteristiche - Features

## Colpo singolo Sequential fire

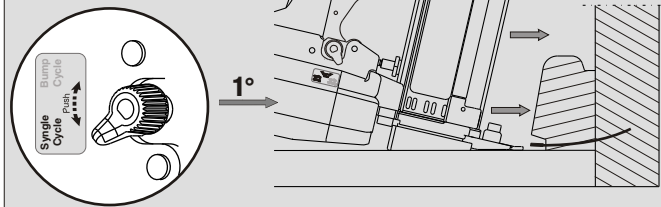

## Colpo martello Bump fire

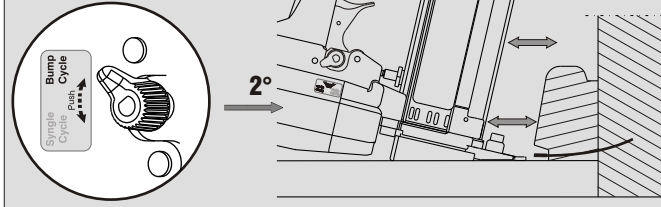

## Regolazione distanza dal vetro Glass distance adjustment

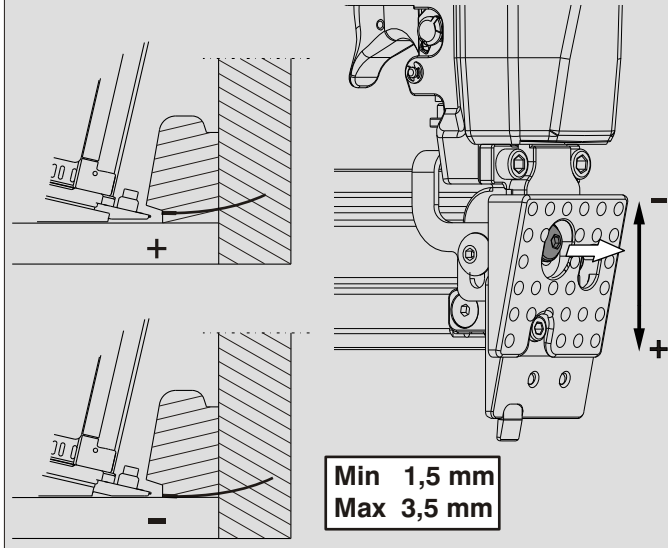

## Regolazione di curvatura Bending radius adjustment

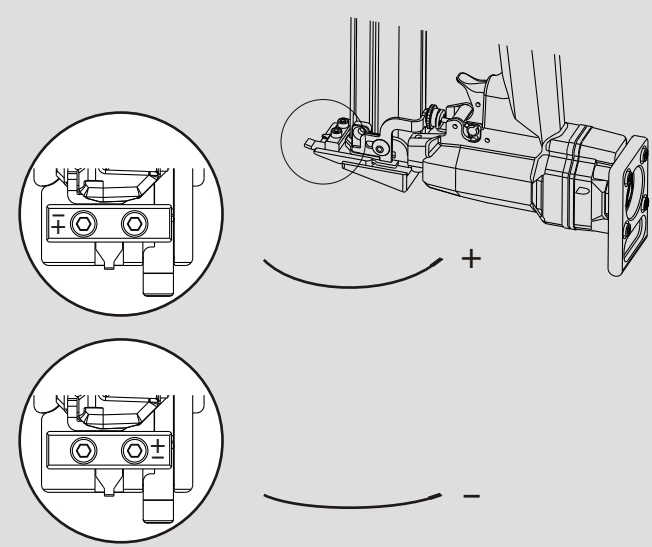

## Regolatore di profondità Depth adjustment

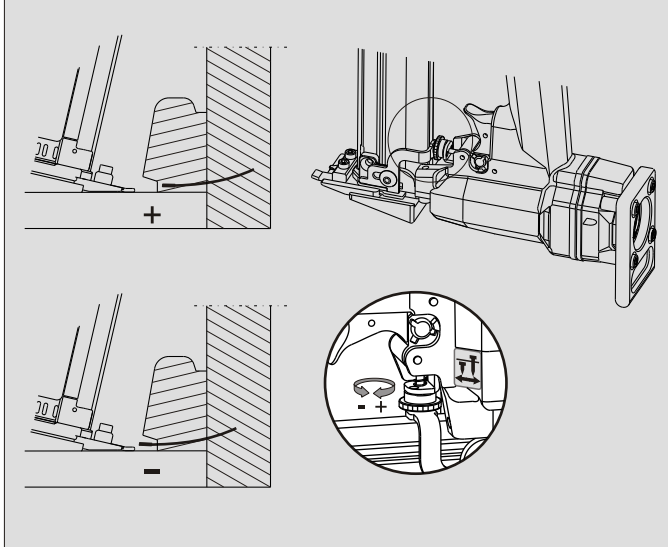

## Segnalatore di fine stecca Strip end indicator

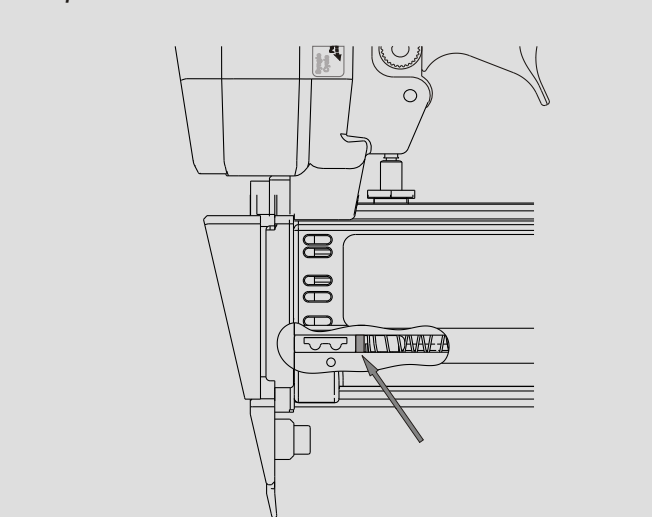

## Disinceppamento macchina Jamming clearance

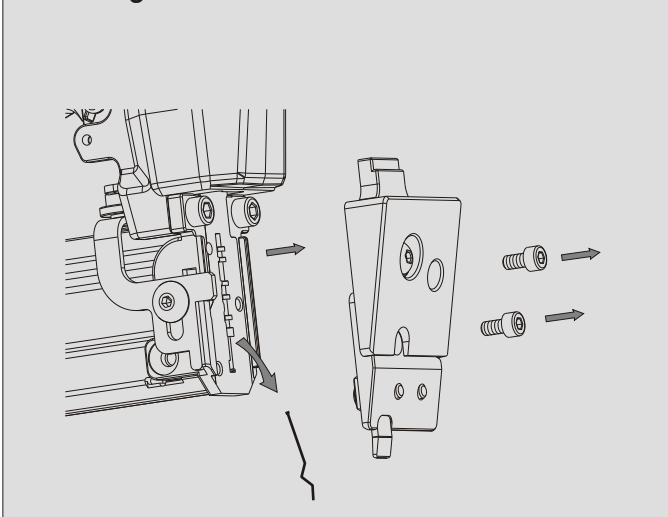

**Manuale d'uso, manutenzione e parti di ricambio**  
**Use, maintenance and spare parts manual**  
**Gebrauchsanweisung, Instandhaltungsrichtlinien und Ersatzteile**  
**Manuel d'utilisation, entretien et pièces de rechange**  
**Manual de uso, mantenimiento y repuestos**

**Parte 2**  
**Part 2**  
**Teil 2**  
**Partie 2**  
**Part 2**

**Manual de utilização, manutenção e partes sobresselentes**  
**Handleiding voor gebruik, onderhoud en reservedelslste**  
**Brugsanvisning, vedligeholdelse og reservedelslste**

**Parte 2**  
**Deel 2**  
**Del 2**



# 12.40 G

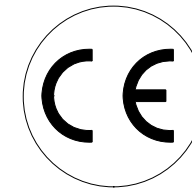

cod. 1211200G

1211200G\_1240G\_1 190411 IV

Dati tecnici Technical data Technische daten	Données techniques Datos tècnicos	Dados tècnicos Technischegegevens Tekniske data
----------------------------------------------------	--------------------------------------	-------------------------------------------------------

<b>Misure impieghiabili mm</b> Usable lengths mm Gebrauchliche Längen mm	Mesures utilisable mm Medidas que se pueden emplear mm	Medidas que se podem utilizar mm Te gebruiken engtes in mm Brugbare laengder i mm	<b>25 ÷ 40</b>
<b>Capacità caricatore n° punti</b> Magazine capacity No. of fasteners Magazinkapazität Nägel	Capacité chargeur n° de points Capacidad cargador n° puntos	Capacitade carregador n° pontos Capaciteit magazijn in aantal spijkers Kapacitet af magasin antal klemme	<b>100</b>
<b>Pressione d'esercizio</b> Working pressure Betriebsdruck	Pression de fonctionnement Presión de trabajo	Pressao de trabalho Werkdruk Arbejds tryk bar	<b>5 ÷ 7 bar</b> <b>70 ÷ 100 psi</b>
<b>Consumo aria litri/colpo</b> Air consumption litres/shot Luftverbrauch Liter/Schlag	Consommation air litre/coup Consumo aire-litros/golpe	Consumo ar litro/golpe Luchtverbruik liter/schot Luftforbrug liter/skud	<b>0,34</b>
<b>Peso kg</b> Weight kg Gewicht kg	Poids kg Peso kg	Peso kg Gewicht in kg Vaegt kg	<b>1,25</b>
<b>Dimensioni (AxBxH) mm</b> Dimensions mm Größe mm	Dimension mm Dimensiones mm	Dimencoes mm Afmetingen in mm Dimensioner mm	<b>252x52x228</b>

EN 12549 :1999 ISO 11201 :1995		
<b>Pressione sonora in pos. operatore</b> Sound pressure at the workstation Lärmintensität am Arbeitsplatz	Pression acoustique près de l'opérateur Presión sonora en posición encargado	Intensidade sonora perto do operador Geluidssterkte op de werkplek Lydstyrke på operatorposten
		$L_{pA,1s}$ (Rif. 20µPa) <b>78,8 dB(A)</b>

EN 12549 :1999 ISO 3744 :1994		
<b>Potenza sonora emessa</b> Emitted sound power Ausgestrahlte Lärmintensität	Puissance acoustique émise Potencia sonora emitida	Potência sonora emitida Uitgestraalde geluidssterkte Udsendt lydstrykke
		$L_{WA,1s}$ (Rif. 1pW) <b>88,5 dB(A)</b>

EN 28662 :1992 ISO 5349 :1986 ISO 8662 -11		
<b>Valore medio ponderato di vibrazione sull'impugnatura</b> Weighted mean value of vibration on the grip Mitteler Vibrationswert, am Griff Gemessen	Valeur moyenne pondérée de vibration mesurée sur la poignée Valor medio ponderado de vibracion medida en la empunadura	Valor medio ponderado de vibracao medida no punho Gewogen gemiddelde vibratiewaarde Middelvaerdi af vibrationer pa handtaget
<b>&lt;2,5 m/s<sup>2</sup></b>		

**Tipo di punto**  
Type of fastener  
Befestigungselement  
Type d'agrafe  
Tipo de punto

Tipo de ponto  
Type nietjes  
Tilspændingstype

### Brads 12

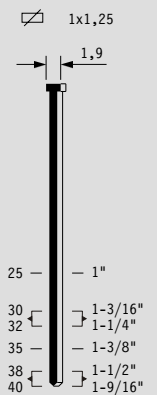

Gauge: 18  
Head width: .075"

Parti di ricambio - Spare parts - Ersatzteile - Pièces de rechange - Piezas de repuesto  
- Partes sobresselentes - Tabel te raadplegen - Reservedele

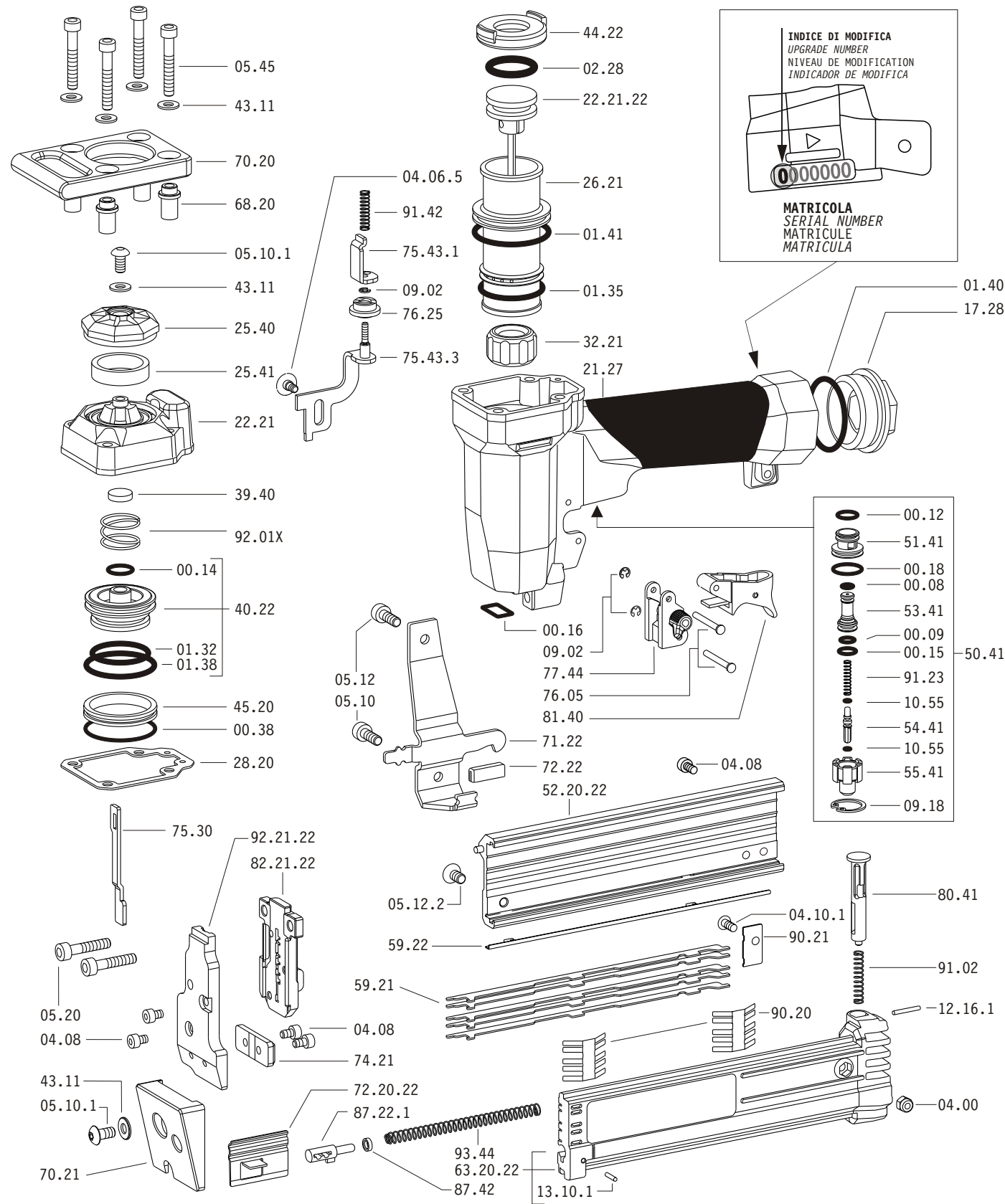

Dotazioni - Equipment - Ausrüstung - Équipements - Equipamiento - Equipamento - Uitrusting - Udstyr

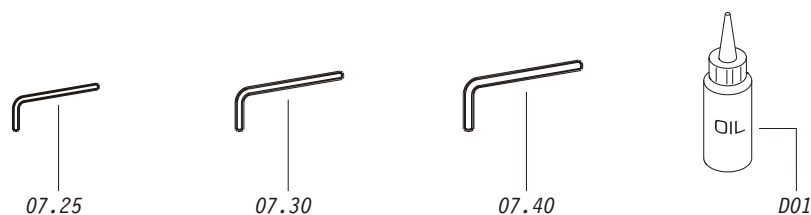

**12.40 G**

cod. 1211200G

Parti di ricambio - Spare parts - Ersatzteile - Pièces de rechange - Piezas de repuesto  
- Partes sobresselentes - Tabel te raadplegen - Reservedele

Cod.	Descrizione	Description
00.08	O-Ring	O-Ring
00.09	O-Ring	O-Ring
00.12	O-Ring	O-Ring
00.14	O-Ring	O-Ring
00.15	O-Ring	O-Ring
00.16	O-Ring	O-Ring
00.18	O-Ring	O-Ring
00.38	O-Ring	O-Ring
01.32	O-Ring	O-Ring
01.35	O-Ring	O-Ring
01.38	O-Ring	O-Ring
01.40	O-Ring	O-Ring
01.41	O-Ring	O-Ring
02.28	O-Ring	O-Ring
04.00	Dado	Nut
04.06.5	Vite	Screw
04.08	Vite	Screw
04.10.1	Vite	Screw
05.10	Vite	Screw
05.10.1	Vite	Screw
05.12	Vite	Screw
05.12.2	Vite	Screw
05.20	Vite	Screw
05.45	Vite	Screw
07.25	Chiave esagonale	Hex. bar wrench
07.30	Chiave esagonale	Hex. bar wrench
07.40	Chiave esagonale	Hex. bar wrench
09.02	Anello elastico	Elastic ring
09.18	Anello elastico	Elastic ring
10.55	O-Ring	O-Ring
13.10.1	Spina	Pin
12.16.1	Spina	Pin
17.28	Tappo	Inlet cap
21.27	Corpo	Body
22.21	Testa	Head
25.40	Deflettore	Exhaust deflector
25.41	Silenziatore	Silencer
26.21	Cilindro	Cylinder
28.20	Guarnizione testa	Head gasket
32.21	Ammortizzatore	Bumper
39.40	Guarnizione scarico	Exhaust seal
40.22	Valvola completa	Valve ass'y
43.11	Rondella	Washer
44.22	Guarnizione	Gasket
45.20	Anello valvola	Ring
50.41	Pulsante completo	Trigger valve ass'y
51.41	Boccola pulsante	Trigger valve housing
53.41	Pistone servovalvola	Valve piston
54.41	Pulsante	Trigger valve
55.41	Raccordo pulsante	Bush
59.21	Distanziale	Spacer
59.22	Spessore	Sliding guide
68.20	Distanziale	Spacer
70.20	Supporto	Support
70.21	Distanziale	Spacer
71.22	Reggicaricatore	Support
72.22	Fermo carrello	Slider-stop
74.21	Piastra	Plate
75.30	Tastatore	Actuator
75.43.1	Rinvio sicura	Contact arm
75.43.3	Sicura	Safety
76.05	Perno	Pin
76.25	Regolatore	Adjusting wheel
77.44	Guida sicura	Safety guide
80.41	Grilletto chiusura	Trigger
81.40	Grilletto comando	Trigger
87.22.1	Portamolla	Spring bearing
87.42	Segnalatore	Signal washer
90.20	Molla	Spring
90.21	Staffa distanziale	Spacer holder
91.02	Molla	Spring
91.42	Molla	Spring
91.23	Molla	Spring
92.01X	Molla	Spring
93.44	Molla	Spring
22.21.22	Battente	Driver
52.20.22	Caricatore	Magazine
63.20.22	Carrello	Slider
72.20.22	Spingipunto	Pusher
82.21.22	Controtestina	Nose
92.21.22	Testina	Nose plate
D01	Boccetta olio	Oiler

- Kit O-Rings - Pakninger

- Kit O-Rings - Dichtungen - Joints - Kit O-Rings

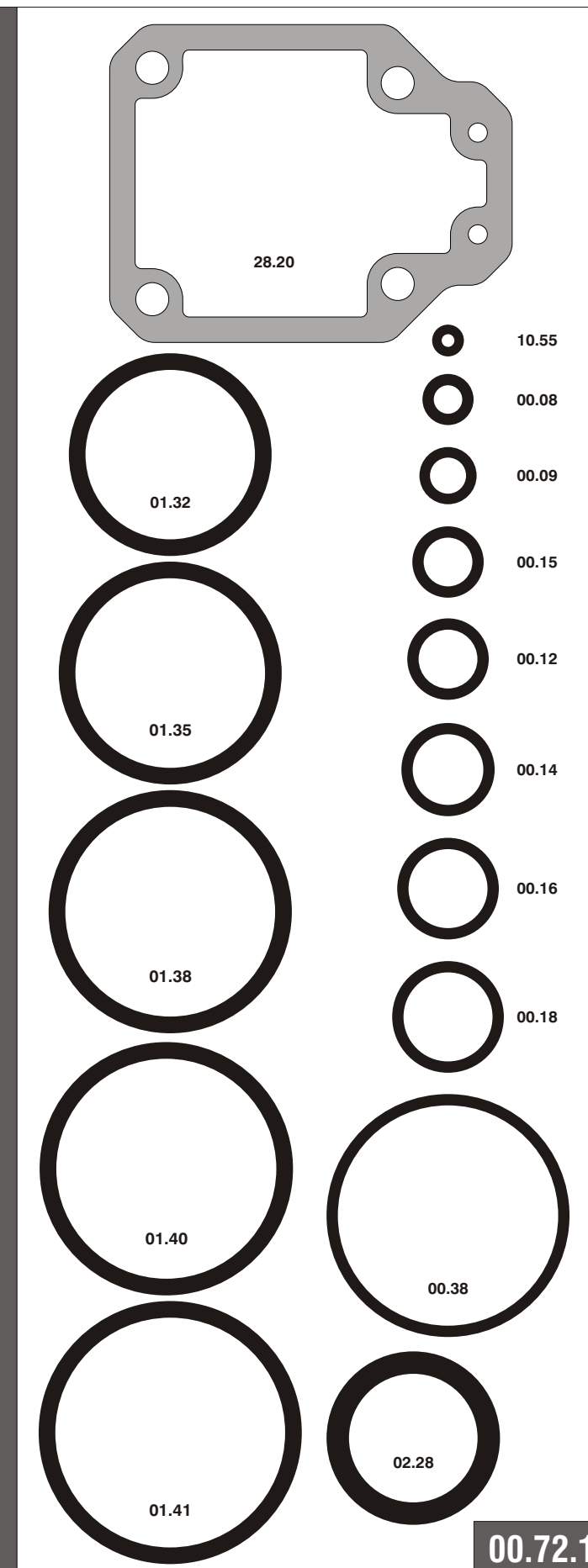

1211200G\_1240G\_1 190411 IV

**12.40 G**

cod. 1211200G

Indice di modifica  
Upgrade number

**1**

1102561