

## Caricamento - Loading

### Caricamento da sotto Bottom load magazine

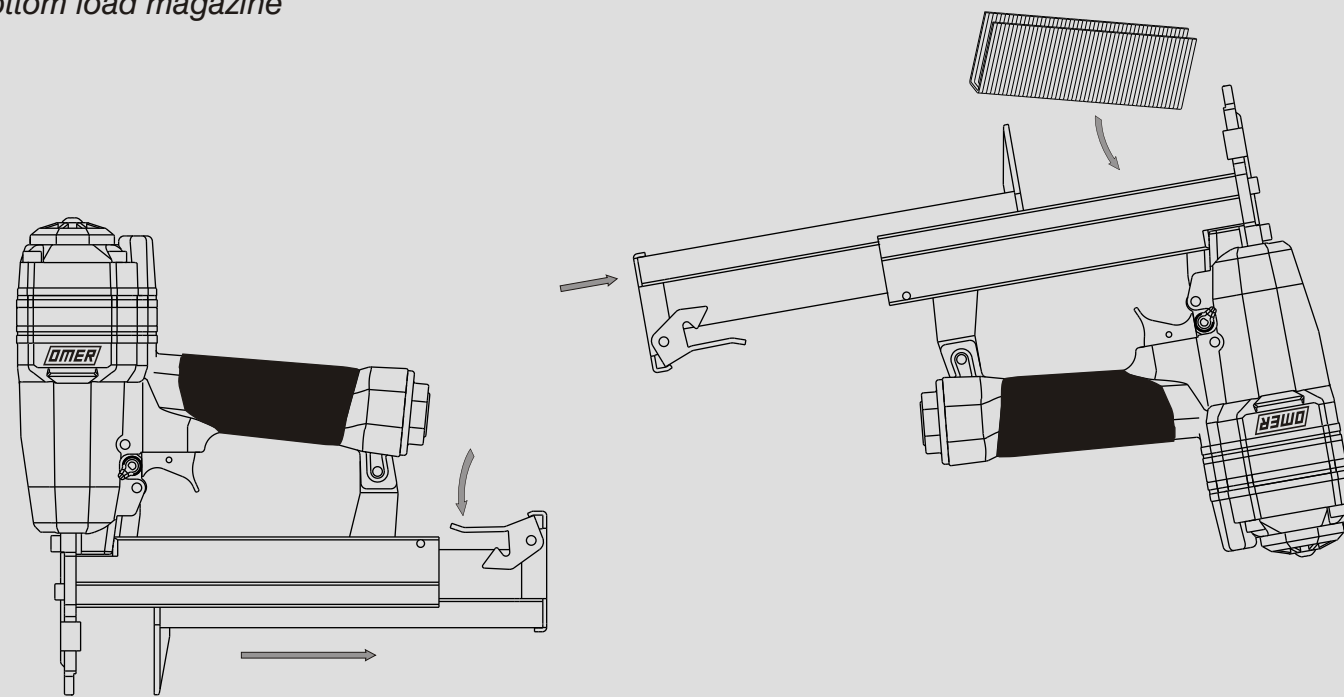

**-Premere il grilletto chiusura**  
Press the magazine latch

**-Arretrare il carrello**  
Pull the slider

**-Capovolgere la graffatrice**  
Turn the tool up side down

**-Inserire le graffe**  
Load the magazine with staples

**-Chiudere il carrello**  
Shut the slider



**Non azionare MAI il grilletto comando o la sicura a contatto durante il caricamento della graffatrice.**  
**NEVER pull the trigger or the contact safety while loading magazine.**

Manuale d'uso, manutenzione e parti di ricambio

Parte 2

Use, maintenance and spare parts manual

Part 2

Gebrauchsanweisung, Instandhaltungsrichtlinien und Ersatzteile

Teil 2

Manuel d'utilisation, entretien et pièces de rechange

Partie 2

Manual de uso, mantenimiento y repuestos

Part 2

Manual de utilização, manutenção e partes sobresselentes

Parte 2

Handleiding voor gebruik, onderhoud en reservedeelsite

Deel 2

Brugsanvisning, vedligeholdelse og reservedeelsite

Del 2



# 4097.25 SL

cod. 1213040

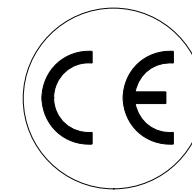

1213040\_409725SL\_1 130411 IV

Dati tecnici Technical data Technische daten	Données techniques Datos técnicos	Dados técnicos Technischegegevens Tecniske data
--	--------------------------------------	---

<b>Misure impiegabili mm</b> Usable lengths mm Gebrauchliche Längen mm	Mesures utilisable mm Medidas que se pueden emplear mm	Medidas que se podem utilizar mm Te gebruiken engtes in mm Brugbare laengder i mm	<b>12 ÷ 25</b>
<b>Capacità caricatore n° punti</b> Magazine capacity No. of fasteners Magazinkapazität Nägel	Capacité chargeur n° de points Capacidad cargador n° puntos	Capacitade carregador n° pontos Capaciteit magazijn in aantal spijkers Kapacitet af magasin antal klemme	<b>135</b>
<b>Pressione d'esercizio</b> Working pressure Betriebsdruck	Pression de fonctionnement Presión de trabajo	Pressao de trabalho Werkdruk Arbejds tryk bar	<b>5 ÷ 6,5 bar</b> <b>70 ÷ 95 psi</b>
<b>Consumo aria litri/colpo</b> Air consumption litres/shot Luftverbrauch Liter/Schlag	Consommation air litre/coup Consumo aire-litros/golpe	Consumo ar litro/golpe Luchtverbruik liter/schot Luftforbrug liter/skud	<b>0,41</b>
<b>Peso kg</b> Weight kg Gewicht kg	Poids kg Peso kg	Peso kg Gewicht in kg Vaegt kg	<b>1,20</b>
<b>Dimensioni (AxBxH) mm</b> Dimensions mm Größe mm	Dimension mm Dimensiones mm	Dimencoes mm Afmetingen in mm Dimensioner mm	<b>219x50x245</b>

EN 12549 :1999 ISO 11201 :1995		L <sub>pA,1s</sub> (Rif. 20μPa)	
<b>Pressione sonora in pos. operatore</b> Sound pressure at the workstation Lärmintensität am Arbeitsplatz	Pression acoustique près de l'opérateur Presión sonora en posición encargado	Intensidade sonora perto do operador Geluidssterkte op de werkplek Lydstyrke på operatorposten	<b>80,2 dB(A)</b>

EN 12549 :1999 ISO 3744 :1994		L <sub>WA,1s</sub> (Rif. 1pW)	
<b>Potenza sonora emessa</b> Emitted sound power Ausgestrahlte Lärmintensität	Puissance acoustique émise Potencia sonora emitida	Potência sonora emitida Uitgestraalde geluidssterkte Udsendt lydstrykke	<b>87 dB(A)</b>

EN 28662 :1992 ISO 5349 :1986 ISO 8662 -11		Valeur moyenne pondérée de vibration mesurée sur la poignée Valor medio ponderado de vibracion medida en la empuñadura	
<b>Valore medio ponderato di vibrazione sull'impugnatura</b> Weighted mean value of vibration on the grip Mittlerer Vibrationswert, am Griff Gemessen	Valeur moyenne pondérée de vibration mesurée sur la poignée Valor medio ponderado de vibracion medida en la empuñadura	Valore medio ponderado de vibracao medida no punho Gewogen gemiddelde vibratiewaarde Middelvaardi af vibrationer pa handtaget	<b>&lt;2,5 m/s<sup>2</sup></b>

**Tipo di punto**  
Type of fastener  
Befestigungselement  
Type d'agrafe  
Tipo de punto  
Tipo de ponto  
Type nietjes  
Tilspændingstype

**4097**

0,65x0,95

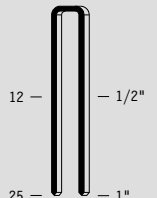

Gauge: 21  
Crown: .170" (3/16")

**40**

0,65x0,95

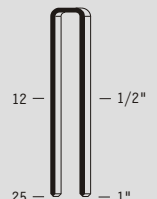

Gauge: 21  
Crown: .180" (3/16")

## Caratteristiche - Features

### Colpo singolo Sequential fire

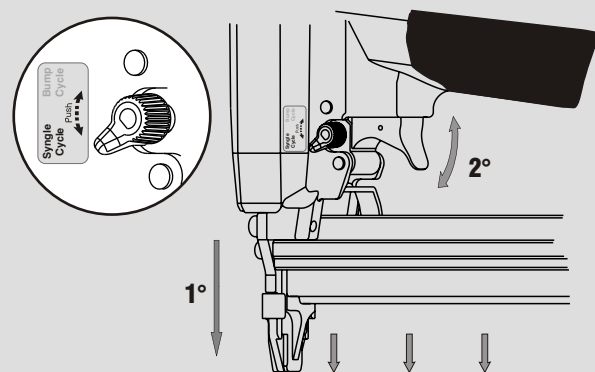

### Colpo martello Bump fire

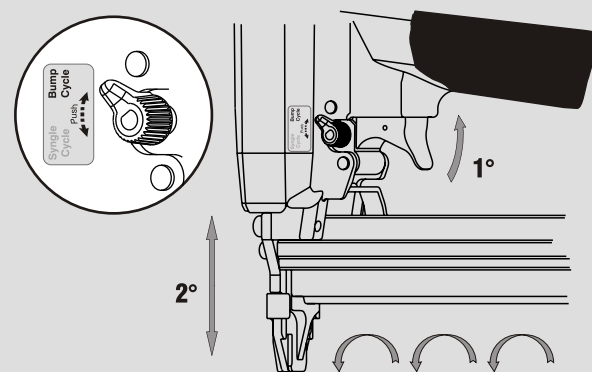

Parti di ricambio - Spare parts - Ersatzteile - Pièces de rechange - Piezas de repuesto  
- Partes sobresselentes - Tabel te raadplegen - Reservedele

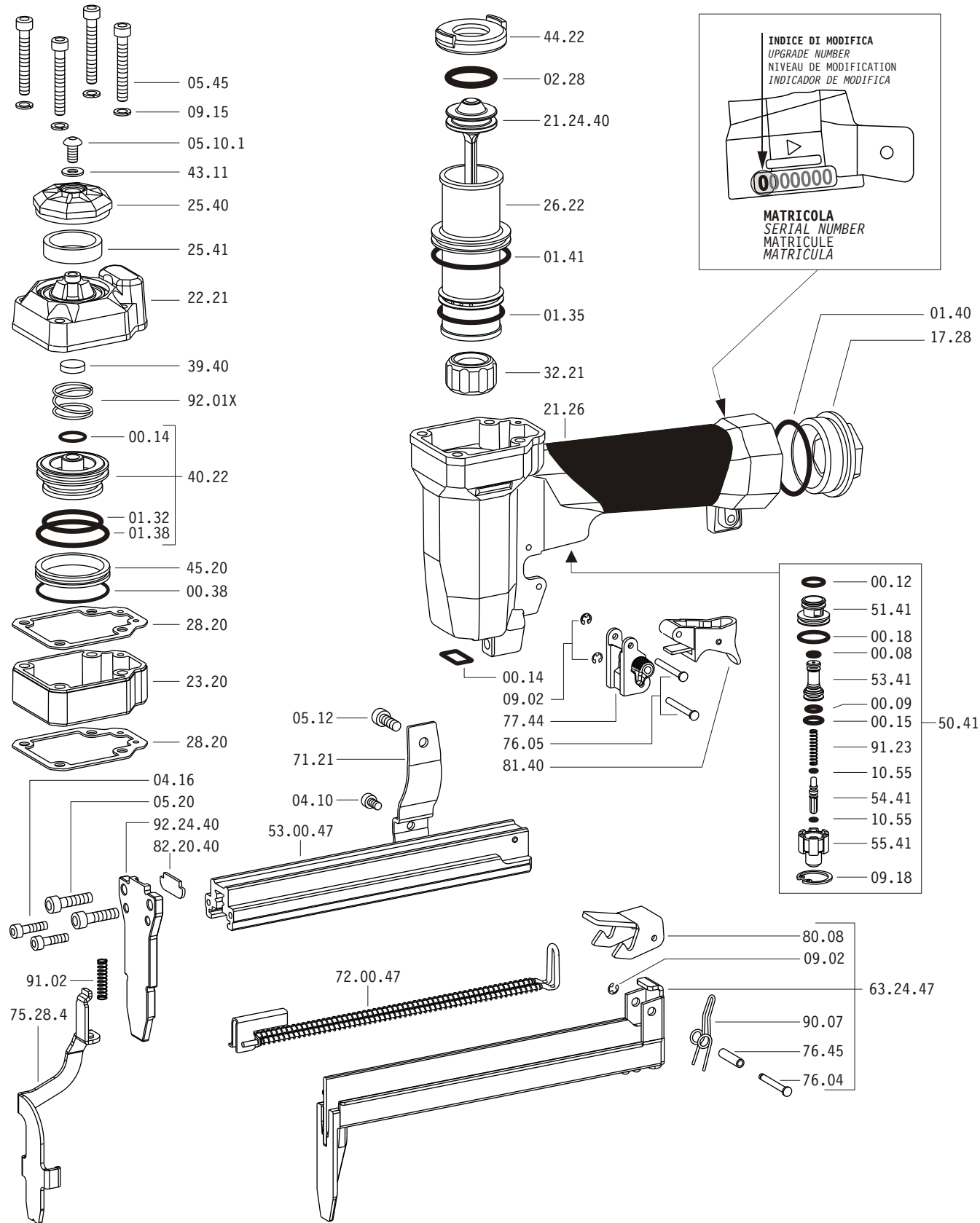

Dotazioni - Equipment - Ausrüstung - Équipements - Equipamiento -  
Equipamento - Uitrusting - Udstyr

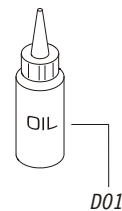

**4097.25 SL**

cod. 1213040

Parti di ricambio - Spare parts - Ersatzteile - Pièces de rechange - Piezas de repuesto  
- Partes sobresselentes - Tabel te raadplegen - Reservedele

Cod.	Descrizione	Description
00.08	O-Ring	O-Ring
00.09	O-Ring	O-Ring
00.12	O-Ring	O-Ring
00.14	O-Ring	O-Ring
00.15	O-Ring	O-Ring
00.18	O-Ring	O-Ring
00.38	O-Ring	O-Ring
01.32	O-Ring	O-Ring
01.35	O-Ring	O-Ring
01.38	O-Ring	O-Ring
01.40	O-Ring	O-Ring
01.41	O-Ring	O-Ring
02.28	O-Ring	O-Ring
04.10	Vite	Screw
04.16	Vite	Screw
05.10.1	Vite	Screw
05.12	Vite	Screw
05.20	Vite	Screw
05.45	Vite	Screw
07.30	Chiave esagonale	Hex. bar wrench
07.40	Chiave esagonale	Hex. bar wrench
09.02	Anello elastico	Elastic ring
09.15	Rondella	Washer
09.18	Anello elastico	Elastic ring
10.55	O-Ring	O-Ring
17.28	Tappo	Inlet cap
21.26	Corpo	Body
22.21	Testa	Head
23.20	Prolunga	Extension
25.40	Deflettore	Exhaust deflector
25.41	Silenziatore	Silencer
26.22	Cilindro	Cylinder
28.20	Guarnizione testa	Head gasket
32.21	Ammortizzatore	Bumper
39.40	Guarnizione scarico	Exhaust seal
40.22	Valvola completa	Valve ass'y
43.11	Rondella	Washer
44.22	Guarnizione	Gasket
45.20	Anello valvola	Ring
50.41	Pulsante completo	Trigger valve ass'y
51.41	Boccola pulsante	Trigger valve housing
53.41	Pistone servovalvola	Valve piston
54.41	Pulsante	Trigger valve
55.41	Raccordo pulsante	Bush
71.21	Reggicaricatore	Support
75.28.4	Sicura	Safety
76.04	Perno	Pin
76.05	Perno	Pin
76.45	Perno molla	Pin
77.44	Guida sicura	Safety guide
80.08	Grilletto chiusura	Trigger
81.40	Grilletto comando	Trigger
90.07	Molla	Spring
91.02	Molla	Spring
91.23	Molla	Spring
92.01X	Molla	Spring
21.24.40	Battente	Driver
53.00.47	Caricatore	Magazine
63.24.47	Carrello	Slider
72.00.47	Spingipunto	Pusher
82.20.40	Controtestina	Nose
92.24.40	Testina	Nose plate
D01	Bocchetta olio	Oiler

- Kit O-Rings - O-ringen - Pakninger

- Kit O-Rings - Dichtungen - Joints - Kit O-Rings -

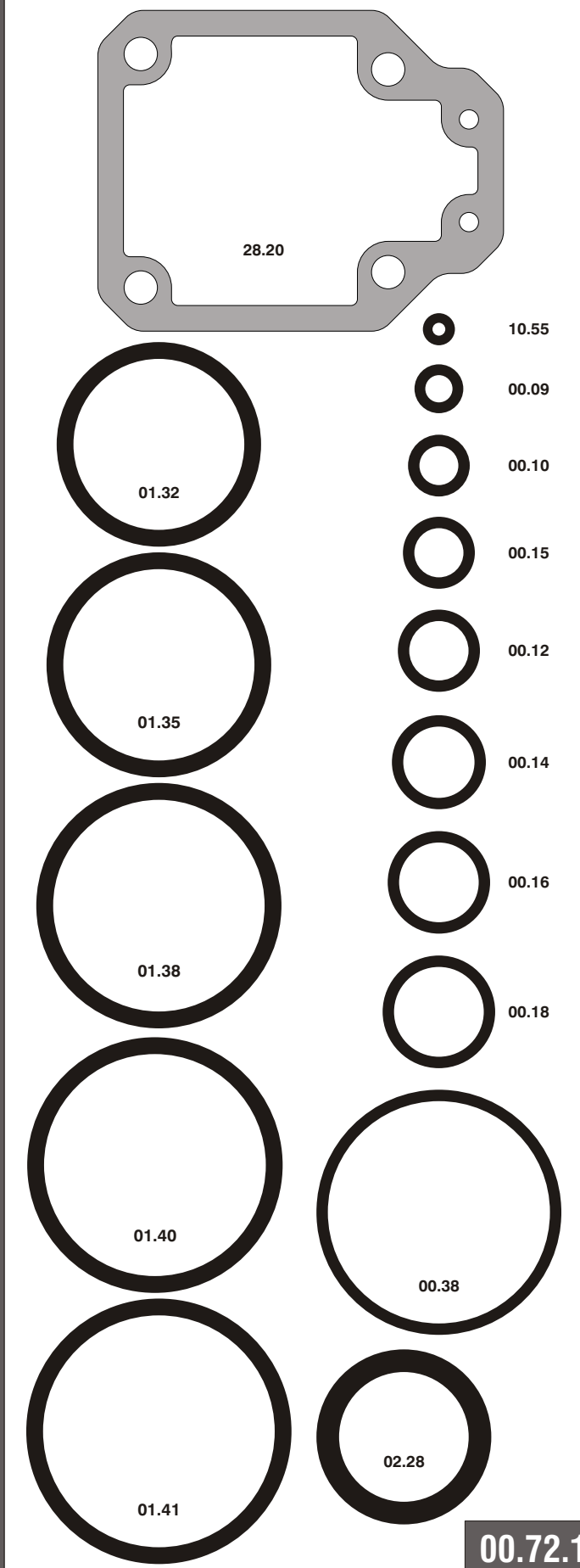

1213040\_409725SL\_1 130411 IV

**4097.25 SL** cod. 1213040

Indice di modifica  
Upgrade number

**1**

1088000