

Caricamento - Loading

Caricamento da sotto Bottom load magazine

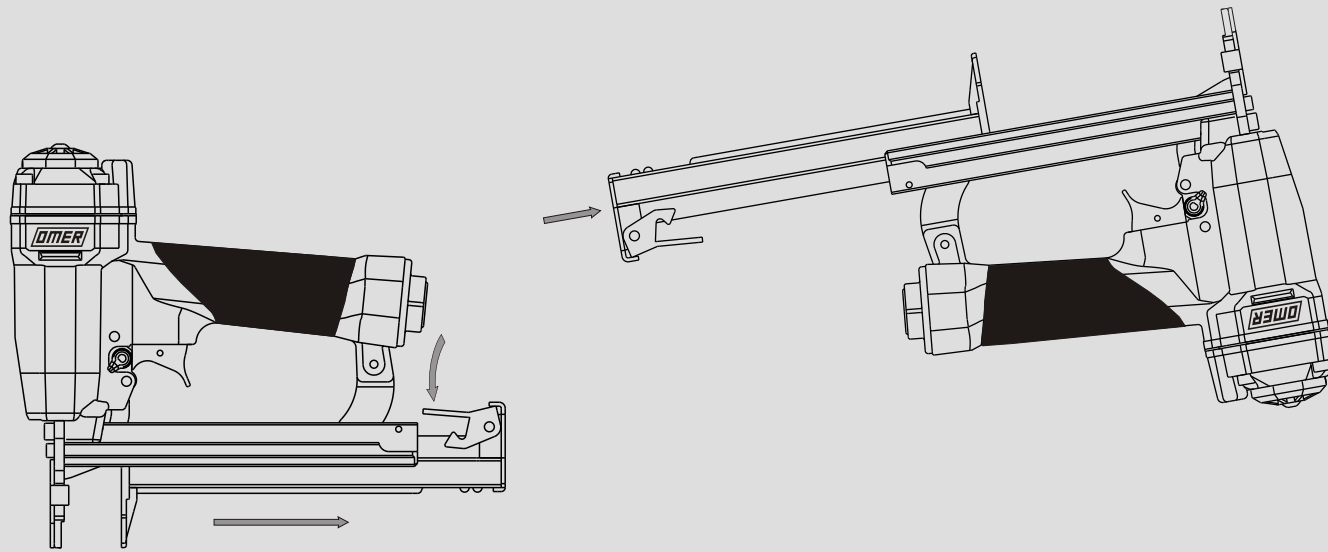

-Premere il grilletto chiusura

Press the magazine latch

-Arretrare il carrello

Pull the slider

-Capovolgere la graffatrice

Turn the tool up side down

-Inserire le graffe

Load the magazine with staples

-Chiudere il carrello

Shut the slider



Non azionare MAI il grilletto comando o la sicura a contatto durante il caricamento della graffatrice.
NEVER pull the trigger or the contact safety while loading magazine.

Manuale d'uso, manutenzione e parti di ricambio

Parte 2

Use, maintenance and spare parts manual

Part 2

Gebrauchsanweisung, Instandhaltungsrichtlinien und Ersatzteile

Teil 2

Manuel d'utilisation, entretien et pièces de rechange

Partie 2

Manual de uso, mantenimiento y repuestos

Part 2

Manual de utilização, manutenção e partes sobresselentes

Parte 2

Handleiding voor gebruik, onderhoud en reservedelslste

Deel 2

Brugsanvisning, vedligeholdelse og reservedelslste

Del 2



98.25

cod. 1214800

1214800_9825_1 100510 IV

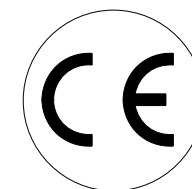

Dati tecnici

Technical data
Technische daten

Données techniques
Datos técnicos

Dados técnicos
Technischegegevens
Tekniske data

Misure impieghiabili mm Usable lengths mm Gebrauchliche Längen mm	Mesures utilisables mm Medidas que se pueden emplear mm	Medidas que se podem utilizar mm Te gebruiken engtes in mm Brugbare laengder i mm	12 ÷ 25
Capacità caricatore n° punti Magazine capacity No. of fasteners Magazinkapazität Nägel	Capacité chargeur n° de points Capacidad cargador n° puntos	Capacitade carregador n° pontos Capaciteit magazijn in aantal spijkers Kapacitet af magasin antal klemme	145
Pressione d'esercizio Working pressure Betriebsdruck	Pression de fonctionnement Presión de trabajo	Pressao de trabalho Werkdruk Arbejds tryk bar	5 ÷ 6,5 bar 70 ÷ 95 psi
Consumo aria litri/colpo Air consumption litres/shot Luftverbrauch Liter/Schlag	Consommation air litre/coup Consumo aire-litros/golpe	Consumo ar litro/golpe Luchtverbruik liter/schot Luftforbrug liter/skud	0,31
Peso kg Weight kg Gewicht kg	Poids kg Peso kg	Peso kg Gewicht in kg Vaegt kg	1,10
Dimensioni (AxBxH) mm Dimensions mm Größe mm	Dimension mm Dimensiones mm	Dimensoes mm Afmetingen in mm Dimensioner mm	219x50x211

EN 12549 :1999 ISO 11201 :1995

Pressione sonora in pos. operatore
Sound pressure at the workstation
Lärmintensität am Arbeitsplatz

Pression acoustique près de l'opérateur
Presión sonora en posición encargado
Lydstyrke på operatorposten

$L_{pA,1s}$
(Rif. 20µPa)
80,1 dB(A)

EN 12549 :1999 ISO 3744 :1994

Potenza sonora emessa
Emitted sound power
Ausgestrahlte Lärmintensität

Puissance acoustique émise
Potencia sonora emitida
Uitgestraalde geluidssterkte
Udsendt lydstrykke

$L_{WA,1s}$
(Rif. 1pW)
86,9 dB(A)

EN 28662 :1992 ISO 5349 :1986 ISO 8662 -11

Valore medio ponderato di vibrazione sull'impugnatura
Weighted mean value of vibration on the grip
Mitteler Vibrationswert, am Griff
Gemessen

Valor medio ponderado de vibracao medida no punho
Gewogen gemiddelde vibratiewaarde
Middelvaardi af vibrationer pa handtaget

<2,5 m/s²

98

0,65x0,95

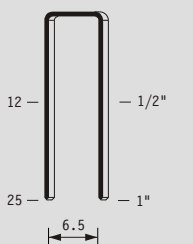

Gauge: 21
Crown: .307" (5/16")

Caratteristiche - Features

Colpo singolo Sequential fire

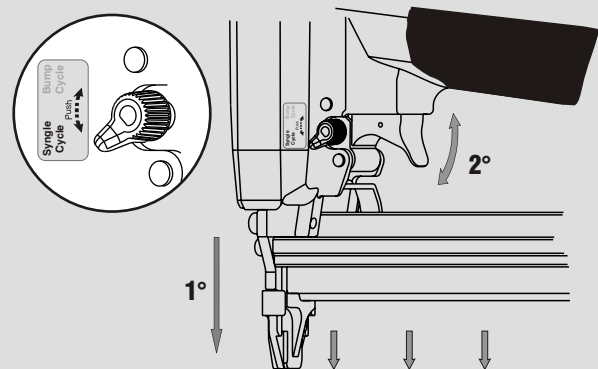

Colpo martello Bump fire

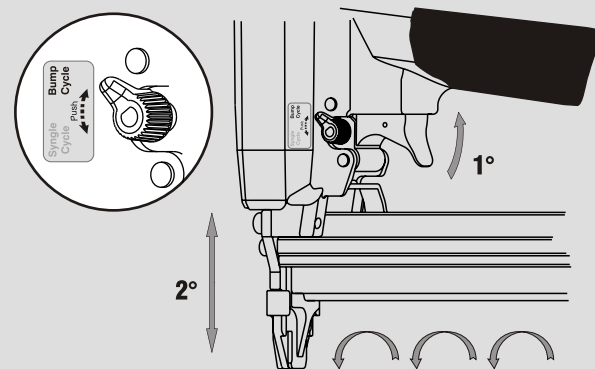

Parti di ricambio - Spare parts - Ersatzteile - Pièces de rechange - Piezas de repuesto
- Partes sobresselentes - Tabel te raadplegen - Reservedele

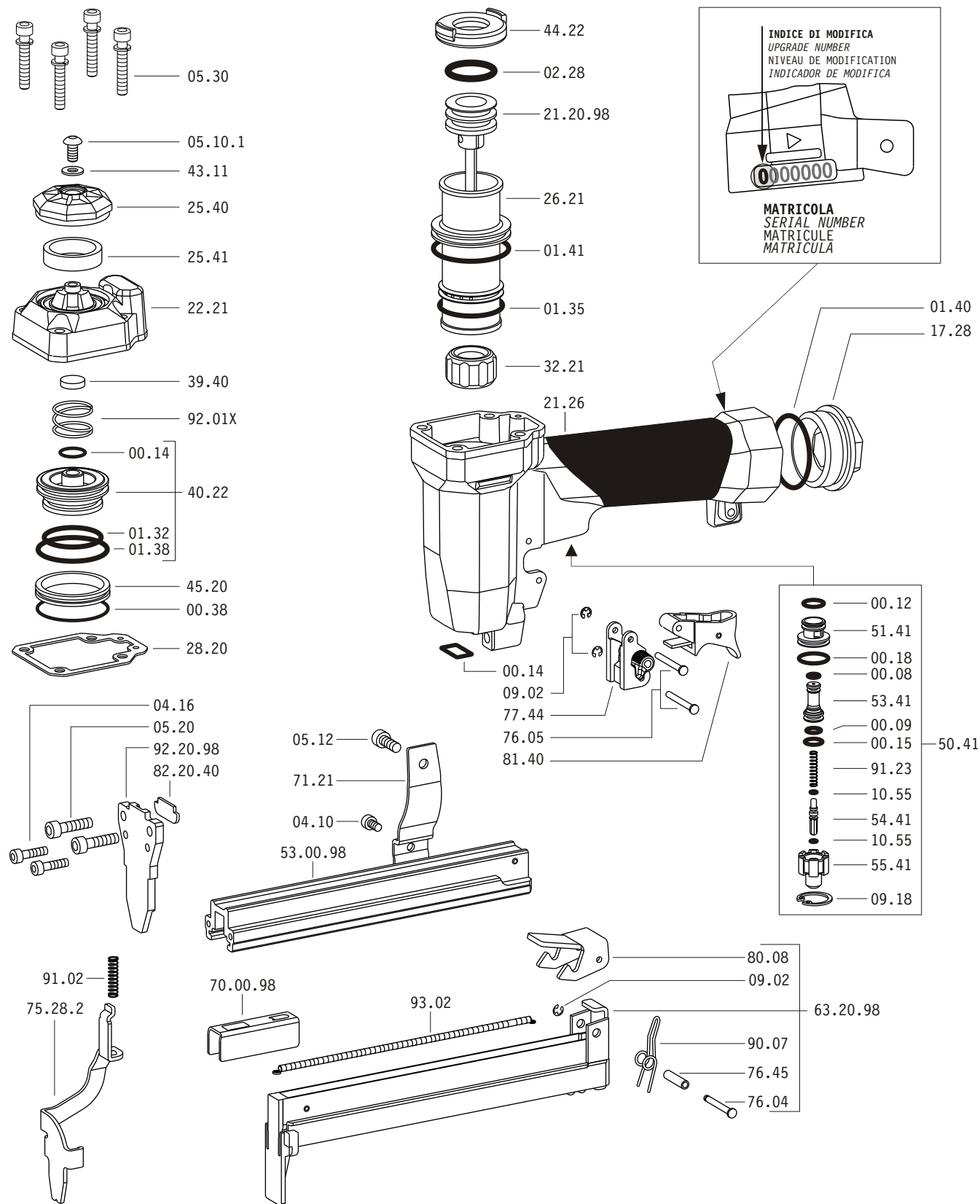

Dotazioni - Equipment - Ausrüstung - Équipements - Equipamiento -
Equipamento - Uitrusting - Udstyr

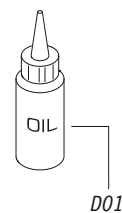

98.25

cod. 1214800

Parti di ricambio - Spare parts - Ersatzteile - Pièces de rechange - Piezas de repuesto
- Partes sobresselentes - Tabel te raadplegen - Reservedele

Cod.	Descrizione	Description
00.08	O-Ring	O-Ring
00.09	O-Ring	O-Ring
00.12	O-Ring	O-Ring
00.14	O-Ring	O-Ring
00.15	O-Ring	O-Ring
00.18	O-Ring	O-Ring
00.38	O-Ring	O-Ring
01.32	O-Ring	O-Ring
01.35	O-Ring	O-Ring
01.38	O-Ring	O-Ring
01.40	O-Ring	O-Ring
01.41	O-Ring	O-Ring
02.28	O-Ring	O-Ring
04.10	Vite	Screw
04.16	Vite	Screw
05.10.1	Vite	Screw
05.12	Vite	Screw
05.20	Vite	Screw
05.30	Vite	Screw
07.30	Chiave esagonale	Hex. bar wrench
07.40	Chiave esagonale	Hex. bar wrench
09.02	Anello elastico	Elastic ring
09.18	Anello elastico	Elastic ring
10.55	O-Ring	O-Ring
17.28	Tappo	Inlet cap
21.26	Corpo	Body
22.21	Testa	Head
25.40	Deflettore	Exhaust deflector
25.41	Silenziatore	Silencer
26.21	Cilindro	Cylinder
28.20	Guarnizione testa	Head gasket
32.21	Ammortizzatore	Bumper
39.40	Guarnizione scarico	Exhaust seal
40.22	Valvola completa	Valve ass'y
43.11	Rondella	Washer
44.22	Guarnizione	Gasket
45.20	Anello valvola	Ring
50.41	Pulsante completo	Trigger valve ass'y
51.41	Boccola pulsante	Trigger valve housing
53.41	Pistone servovalvola	Valve piston
54.41	Pulsante	Trigger valve
55.41	Raccordo pulsante	Bush
71.21	Reggicaricatore	Support
75.28.2	Sicura	Safety
76.04	Perno	Pin
76.05	Perno	Pin
76.45	Perno molla	Pin
77.44	Guida sicura	Safety guide
80.08	Grilletto chiusura	Trigger
81.40	Grilletto comando	Trigger
90.07	Molla	Spring
91.02	Molla	Spring
91.23	Molla	Spring
92.01X	Molla	Spring
93.02	Molla	Spring
21.20.98	Battente	Driver
53.00.98	Caricatore	Magazine
63.20.98	Carrello	Slider
70.00.98	Spingipunto	Pusher
82.20.40	Controtestina	Nose
92.20.98	Testina	Nose plate
D01	Bocchetta olio	Oiler

- Kit O-Rings - O-ringen - Pakninger

- Guarnizioni - Dichtungen - Joints - Kit O-Rings -

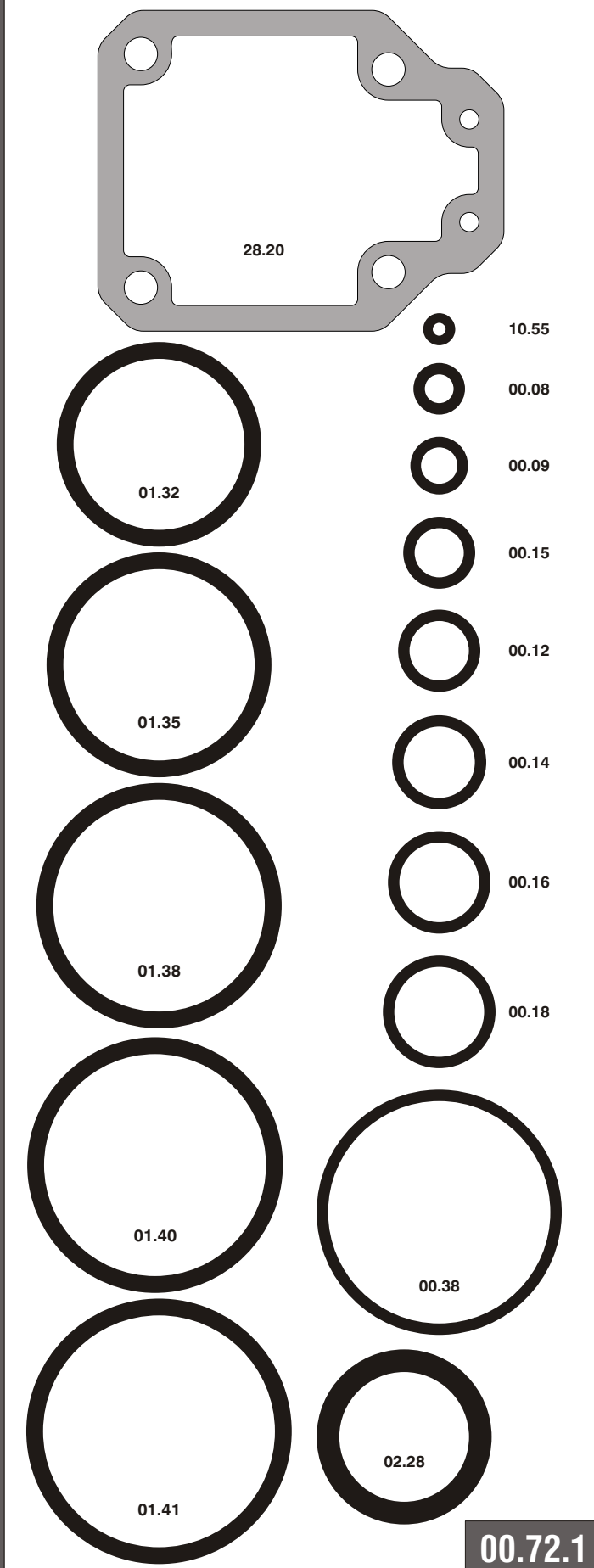

1214800_9825_1 100510 IV

98.25

cod. 1214800

Indice di modifica
Upgrade number

1

1088067