

## Caricamento - Loading

### Caricamento da sotto Bottom load magazine

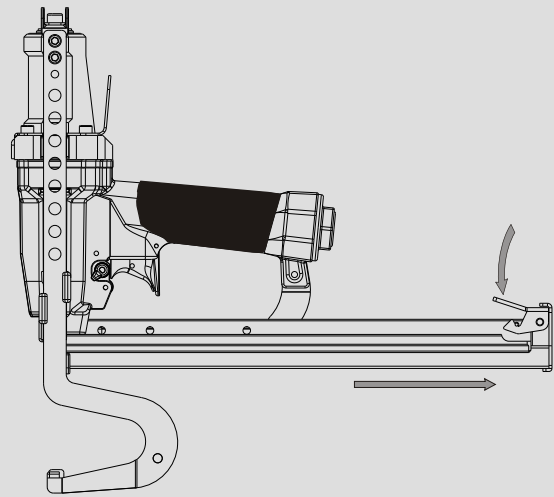

- Capovolgere la graffatrice  
Turn the tool up side down
- Inserire le graffe  
Load the magazine with staples
- Chiudere il carrello  
Shut the slider

- Premere il grilletto chiusura  
Press the magazine latch
- Arretrare il carrello  
Pull the slider



**Non azionare MAI il grilletto comando durante il caricamento della graffatrice.**  
NEVER pull the trigger while loading magazine.

## Caratteristiche - Features

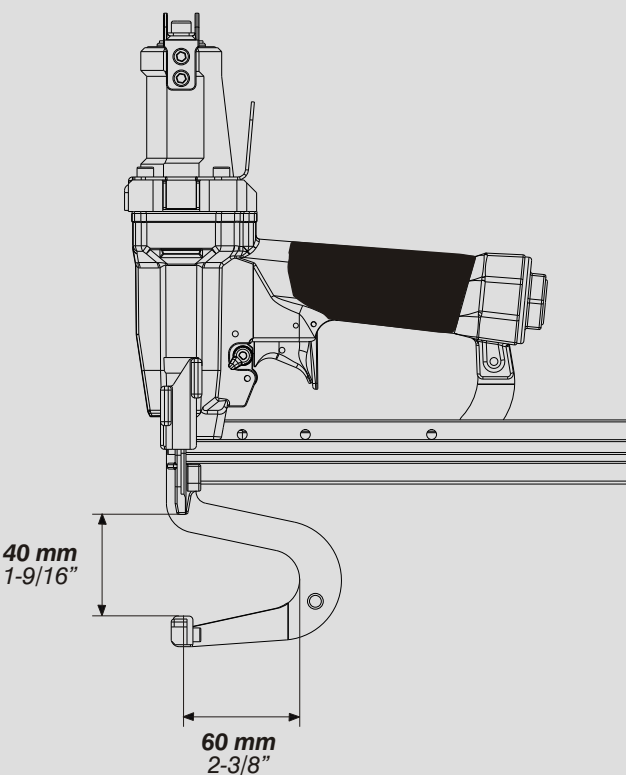

**Posizione in sicura**  
Safety position

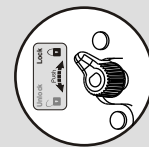

**Pronta a sparare**  
Ready to fire

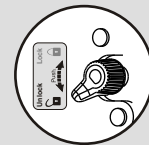

Manuale d'uso, manutenzione e parti di ricambio	Parte 2
Use, maintenance and spare parts manual	Part 2
Gebrauchsanweisung, Instandhaltungsrichtlinien und Ersatzteile	Teil 2
Manuel d'utilisation, entretien et pièces de rechange	Partie 2
Manual de uso, mantenimiento y repuestos	Part 2
Manual de utilização, manutenção e partes sobresselentes	Parte 2
Handleiding voor gebruik, onderhoud en reservedelslste	Deel 2
Brugsanvisning, vedligeholdelse og reservedelslste	Del 2



# PL 88 SJ

cod. 12166510-3724

12166510-3724\_PL 88SJ\_1 171210 IV

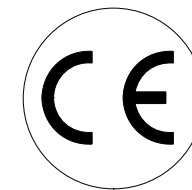

Dati tecnici Technical data Technische daten	Données techniques Datos técnicos	Dados técnicos Technischegegevens Tekniske data
--	--------------------------------------	---

<b>Misure impiegabili mm</b> Usable lengths mm Gebrauchliche Längen mm	Mesures utilisable mm Medidas que se pueden emplear mm	Medidas que se podem utilizar mm Te gebruiken engtes in mm Brugbare laengder i mm	<b>12 ÷ 25</b>
<b>Capacità caricatore n° punti</b> Magazine capacity No. of fasteners Magazinkapazität Nägel	Capacité chargeur n° de points Capacidad cargador n° puntos	Capacitade carregador n° pontos Capaciteit magazijn in aantal spijkers Kapacitet af magasin antal klemme	<b>200</b>
<b>Pressione d'esercizio</b> Working pressure Betriebsdruck	Pression de fonctionnement Presión de trabajo	Pressao de trabalho Werkdruk Arbejds tryk bar	<b>5 ÷ 6,5 bar 70 ÷ 95 psi</b>
<b>Consumo aria litri/colpo</b> Air consumption litres/shot Luftverbrauch Liter/Schlag	Consommation air litre/coup Consumo aire-litros/golpe	Consumo ar litro/golpe Luchtverbruik liter/schot Luftforbrug liter/skud	<b>0,25</b>
<b>Peso kg</b> Weight kg Gewicht kg	Poids kg Peso kg	Peso kg Gewicht in kg Vaegt kg	<b>2,15</b>
<b>Dimensioni (AxBxH) mm</b> Dimensions mm Größe mm	Dimension mm Dimensiones mm	Dimensoes mm Afmetingen in mm Dimensioner mm	<b>360x70x310</b>
<b>EN 12549 :1999 ISO 11201 :1995</b> <b>Pressione sonora in pos. operatore</b> Sound pressure at the workstation Lärmintensität am Arbeitsplatz	Pression acoustique près de l'opérateur Presión sonora en posición encargado	Intensidade sonora perto do operador Geluidssterkte op de werkplek Lydstyrke på operatorposten	$L_{pA,1s}$ (Rif. 20µPa) <b>80,1 dB(A)</b>
<b>EN 12549 :1999 ISO 3744 :1994</b> <b>Potenza sonora emessa</b> Emitted sound power Ausgestrahlte Lärmintensität	Puissance acoustique émise Potencia sonora emitida	Potência sonora emitida Uitgestraalde geluidssterkte Udsendt lydstryke	$L_{WA,1s}$ (Rif. 1pW) <b>86,9 dB(A)</b>
<b>EN 28662 :1992 ISO 5349 :1986 ISO 8662 -11</b> <b>Valore medio ponderato di vibrazione sull'impugnatura</b> Weighted mean value of vibration on the grip Mitteler Vibrationswert, am Griff Gemessen	Valeur moyenne pondérée de vibration mesurée sur la poignée Valor medio ponderado de vibracion medida en la empunadura	Valor medio ponderado de vibracao medida no punho Gewogen gemiddelde vibratiewaarde Middelvaerdi af vibrationer pa handtaget	<b>&lt;2,5 m/s<sup>2</sup></b>

**Tipo di punto**  
Type of fastener  
Befestigungselement  
Type d'agrafe  
Tipo de punto  
Tipo de ponto  
Type nietjes  
Tilspændingstype

**88**

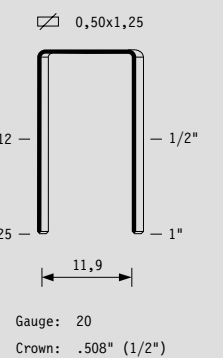

Gauge: 20  
Crown: .508" (1/2")

Parti di ricambio - Spare parts - Ersatzteile - Pièces de rechange - Piezas de repuesto  
- Partes sobresselentes - Tabel te raadplegen - Reservedele

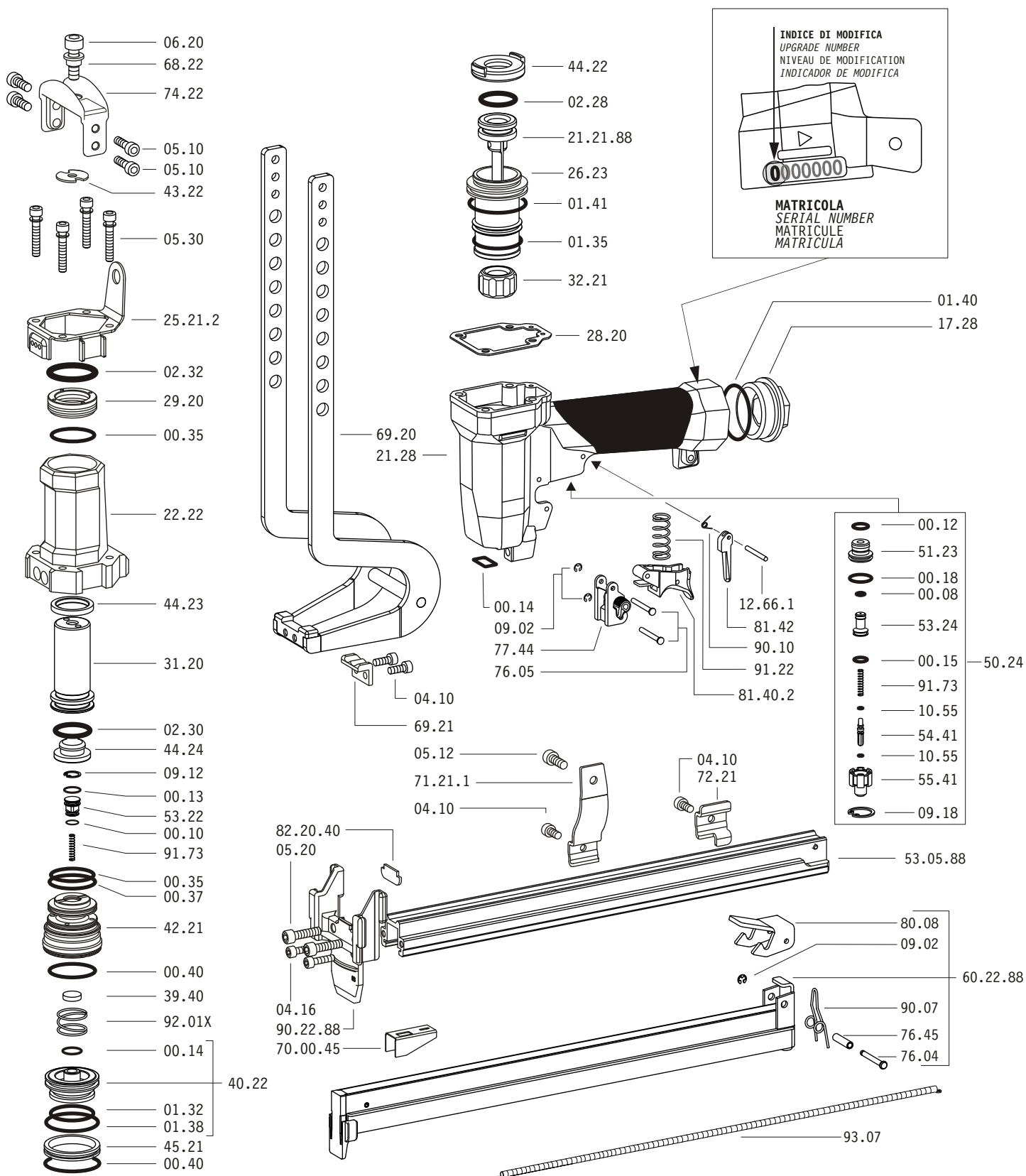

Dotazioni - Equipment - Ausrüstung - Équipements - Equipamiento -  
Equipamento - Uitrusting - Udstyr

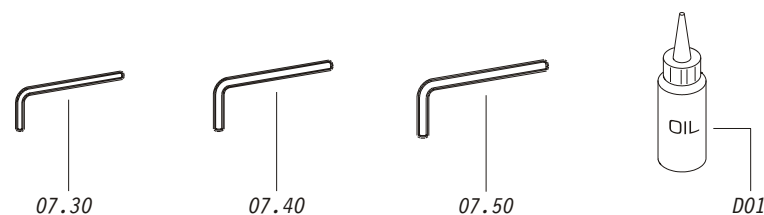

**PL 88 SJ**

cod. 12166510-3724

Parti di ricambio - Spare parts - Ersatzteile - Pièces de rechange - Piezas de repuesto  
- Partes sobresselentes - Tabel te raadplegen - Reservedele

Cod.	Descrizione	Description
00.08	O-Ring	O-Ring
00.10	O-Ring	O-Ring
00.12	O-Ring	O-Ring
00.13	O-Ring	O-Ring
00.14	O-Ring	O-Ring
00.15	O-Ring	O-Ring
00.18	O-Ring	O-Ring
00.35	O-Ring	O-Ring
00.37	O-Ring	O-Ring
00.40	O-Ring	O-Ring
01.32	O-Ring	O-Ring
01.35	O-Ring	O-Ring
01.38	O-Ring	O-Ring
01.40	O-Ring	O-Ring
01.41	O-Ring	O-Ring
02.28	O-Ring	O-Ring
02.30	O-Ring	O-Ring
02.32	O-Ring	O-Ring
04.10	Vite	Screw
04.16	Vite	Screw
05.10	Vite	Screw
05.12	Vite	Screw
05.20	Vite	Screw
05.30	Vite	Screw
06.20	Vite	Screw
07.30	Chiave esagonale	Hex. bar wrench
07.40	Chiave esagonale	Hex. bar wrench
07.50	Chiave esagonale	Hex. bar wrench
09.02	Anello elastico	Elastic ring
09.12	Anello elastico	Elastic ring
09.18	Anello elastico	Elastic ring
10.55	O-Ring	O-Ring
12.66.1	Spina	Pin
17.28	Tappo	Inlet cap
21.28	Corpo	Body
22.22	Testa	Head
25.21.2	Deflettore	Exhaust deflector
26.23	Cilindro	Cylinder
28.20	Guarnizione testa	Head gasket
29.20	Bronzina	Bronze ring
31.20	Pistone Ganascia	Jaw's piston
32.21	Ammortizzatore	Bumper
39.40	Guarnizione scarico	Exhaust seal
40.22	Valvola completa	Valve ass'y
42.21	Sede Valvola	Valve housing
43.22	Rondella	Washer
44.22	Guarnizione	Gasket
44.23	Ammortizzatore Sup	Upper bumper
44.24	Ammortizzatore Inf	Lower bumper
45.21	Anello valvola	Ring
50.24	Pulsante completo	Trigger valve ass'y
51.23	Boccola pulsante	Trigger valve housing
53.22	Pistone servovalvola	Valve piston
53.24	Pistone servovalvola	Valve piston
54.41	Pulsante	Trigger valve
55.41	Raccordo pulsante	Bush
68.22	Distanziale rondella	Pacer
69.20	Gruppo ganascia	Jaw kit
69.21	Ribattitore	Riveter
71.21.1	Reggicaricatore	Support
72.21	Fermo carrello	Slider-Stop
74.22	Staffa	Hanger
76.04	Perno	Pin
76.05	Perno	Pin
76.45	Perno carter	Pin
77.44	Guida sicura	Safety guide
80.08	Grilletto chiuso	Trigger
81.40.2	Grilletto comando	Trigger
81.42	Controgrilletto	Trigger safety
90.07	Molla carter	Spring
90.10	Molla	Spring
91.22	Molla	Spring
91.73	Molla	Spring
92.01X	Molla	Spring
93.07	Molla	Spring
21.21.88	Battente	Driver
53.05.88	Caricatore	Magazine
60.22.88	Carrello	Slider
70.00.45	Spingipunto	Pusher
82.20.40	Controtestina	Nose
90.22.88	Testina	Nose plate
D01	Bocchetta olio	Oiler

- Kit O-Rings - O-ringen - Pakninger -  
Guarnizioni - O-Rings - Dichtungen - Joints - Kit O-Rings -

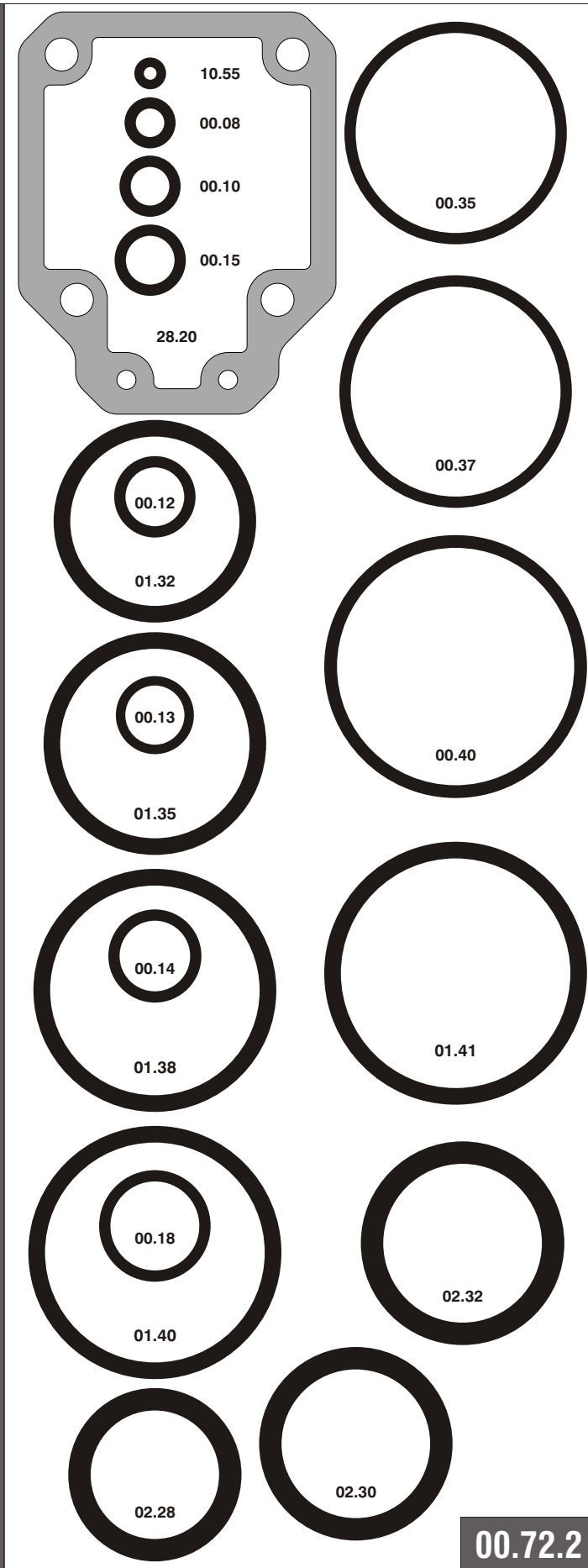

12166510-3724\_PL\_88SJ\_1\_171210\_IV

**PL 88 SJ**

cod. 12166510-3724

Indice di modifica  
Upgrade number

**1**

1275290