

Caricamento - Loading

Caricamento da sotto Bottom load magazine

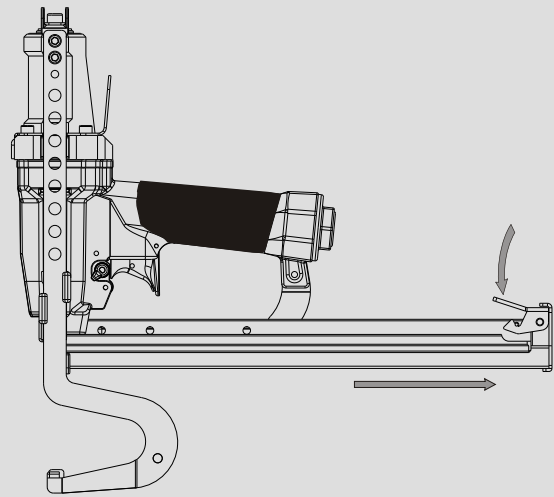

- Capovolgere la graffatrice
Turn the tool up side down
- Inserire le graffe
Load the magazine with staples
- Chiudere il carrello
Shut the slider

- Premere il grilletto chiusura
Press the magazine latch
- Arretrare il carrello
Pull the slider



Non azionare MAI il grilletto comando durante il caricamento della graffatrice.
NEVER pull the trigger while loading magazine.

Caratteristiche - Features

Posizione in sicura
Safety position

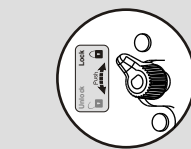

Pronta a sparare
Ready to fire



40 mm
1-9/16"

60 mm
2-3/8"



| | |
|--|----------|
| Manuale d'uso, manutenzione e parti di ricambio | Parte 2 |
| Use, maintenance and spare parts manual | Part 2 |
| Gebrauchsanweisung, Instandhaltungsrichtlinien und Ersatzteile | Teil 2 |
| Manuel d'utilisation, entretien et pièces de rechange | Partie 2 |
| Manual de uso, mantenimiento y repuestos | Part 2 |
| Manual de utilização, manutenção e partes sobresselentes | Parte 2 |
| Handleiding voor gebruik, onderhoud en reservedeelsite | Deel 2 |
| Brugsanvisning, vedligeholdelse og reservedeelsite | Del 2 |



PL 88 SJ

cod. 12166510

12166510_PL 88SJ_1 100510 IV

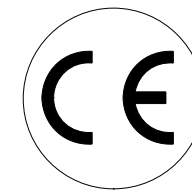

| Dati tecnici Technical data Technische daten | Données techniques Datos técnicos | Dados técnicos Technischegegevens Tekniske data | |
|--|---|--|--|
| Misure impiegabili mm Usable lengths mm Gebrauchliche Längen mm | Mesures utilisable mm Medidas que se pueden emplear mm | Medidas que se podem utilizar mm Te gebruiken engtes in mm Brugbare laengder i mm | 12 ÷ 25 |
| Capacità caricatore n° punti Magazine capacity No. of fasteners Magazinkapazität Nägel | Capacité chargeur n° de points Capacidad cargador n° puntos | Capacitade carregador n° pontos Capaciteit magazijn in aantal spijkers Kapacitet af magasin antal klemme | 200 |
| Pressione d'esercizio Working pressure Betriebsdruck | Pression de fonctionnement Presión de trabajo | Pressao de trabalho Werkdruk Arbejds tryk bar | 5 ÷ 6,5 bar 70 ÷ 95 psi |
| Consumo aria litri/colpo Air consumption litres/shot Luftverbrauch Liter/Schlag | Consommation air litre/coup Consumo aire-litros/golpe | Consumo ar litro/golpe Luchtverbruik liter/schot Luftforbrug liter/skud | 0,25 |
| Peso kg Weight kg Gewicht kg | Poids kg Peso kg | Peso kg Gewicht in kg Vaegt kg | 2,15 |
| Dimensioni (AxBxH) mm Dimensions mm Größe mm | Dimension mm Dimensiones mm | Dimensoes mm Afmetingen in mm Dimensioner mm | 360x70x310 |
| EN 12549 :1999 ISO 11201 :1995 Pressione sonora in pos. operatore Sound pressure at the workstation Lärmintensität am Arbeitsplatz | Pression acoustique près de l'opérateur Presión sonora en posición encargado | Intensidade sonora perto do operador Geluidssterkte op de werkplek Lydstyrke på operatorposten | $L_{pA,1s}$ (Rif. 20µPa) 80,1 dB(A) |
| EN 12549 :1999 ISO 3744 :1994 Potenza sonora emessa Emitted sound power Ausgestrahlte Lärmintensität | Puissance acoustique émise Potencia sonora emitida | Potência sonora emitida Uitgestraalde geluidssterkte Udsendt lydstryke | $L_{WA,1s}$ (Rif. 1pW) 86,9 dB(A) |
| EN 28662 :1992 ISO 5349 :1986 ISO 8662 -11 Valore medio ponderato di vibrazione sull'impugnatura Weighted mean value of vibration on the grip Mitteler Vibrationswert, am Griff Gemessen | Valeur moyenne pondérée de vibration mesurée sur la poignée Valor medio ponderado de vibracion medida en la empunadura | Valor medio ponderado de vibracao medida no punho Gewogen gemiddelde vibratiewaarde Middelvaardi af vibrationer pa handtaget | <2,5 m/s² |

Tipo di punto
Type of fastener
Befestigungselement
Type d'agrafe
Tipo de punto
Tipo de ponto
Type nietjes
Tilspændingstype

88

0,50x1,25

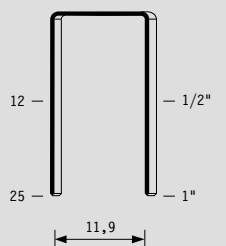

Gauge: 20
Crown: .508" (1/2")

Parti di ricambio - Spare parts - Ersatzteile - Pièces de rechange - Piezas de repuesto
- Partes sobresselentes - Tabel te raadplegen - Reservedele

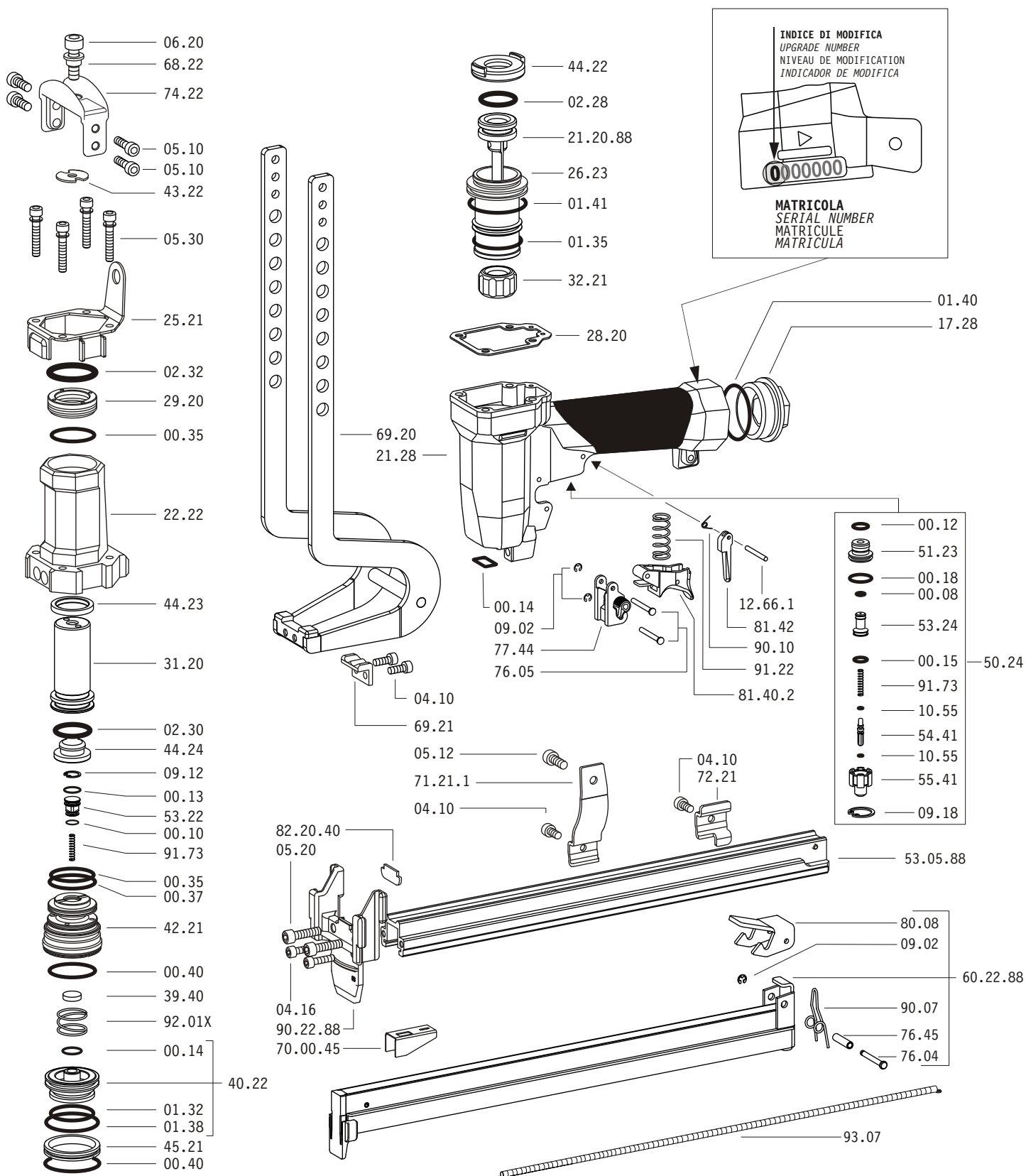

Dotazioni - Equipment - Ausrüstung - Équipements - Equipamiento - Equipamento - Uitrusting - Udstyr

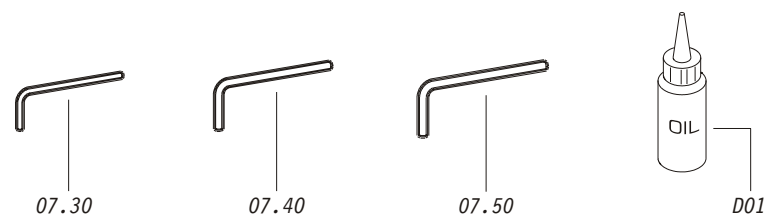

PL 88 SJ

cod. 12166510

Parti di ricambio - Spare parts - Ersatzteile - Pièces de rechange - Piezas de repuesto
- Partes sobresselentes - Tabel te raadplegen - Reservedele

| Cod. | Descrizione | Description |
|----------|----------------------|-----------------------|
| 00.08 | O-Ring | O-Ring |
| 00.10 | O-Ring | O-Ring |
| 00.12 | O-Ring | O-Ring |
| 00.13 | O-Ring | O-Ring |
| 00.14 | O-Ring | O-Ring |
| 00.15 | O-Ring | O-Ring |
| 00.18 | O-Ring | O-Ring |
| 00.35 | O-Ring | O-Ring |
| 00.37 | O-Ring | O-Ring |
| 00.40 | O-Ring | O-Ring |
| 01.32 | O-Ring | O-Ring |
| 01.35 | O-Ring | O-Ring |
| 01.38 | O-Ring | O-Ring |
| 01.40 | O-Ring | O-Ring |
| 01.41 | O-Ring | O-Ring |
| 02.28 | O-Ring | O-Ring |
| 02.30 | O-Ring | O-Ring |
| 02.32 | O-Ring | O-Ring |
| 04.10 | Vite | Screw |
| 04.16 | Vite | Screw |
| 05.10 | Vite | Screw |
| 05.12 | Vite | Screw |
| 05.20 | Vite | Screw |
| 05.30 | Vite | Screw |
| 06.20 | Vite | Screw |
| 07.30 | Chiave esagonale | Hex. bar wrench |
| 07.40 | Chiave esagonale | Hex. bar wrench |
| 07.50 | Chiave esagonale | Hex. bar wrench |
| 09.02 | Anello elastico | Elastic ring |
| 09.12 | Anello elastico | Elastic ring |
| 09.18 | Anello elastico | Elastic ring |
| 10.55 | O-Ring | O-Ring |
| 12.66.1 | Spina | Pin |
| 17.28 | Tappo | Inlet cap |
| 21.28 | Corpo | Body |
| 22.22 | Testa | Head |
| 25.21 | Deflettore | Exhaust deflector |
| 26.23 | Cilindro | Cylinder |
| 28.20 | Guarnizione testa | Head gasket |
| 29.20 | Bronzina | Bronze ring |
| 31.20 | Pistone Ganascia | Jaw's piston |
| 32.21 | Ammortizzatore | Bumper |
| 39.40 | Guarnizione scarico | Exhaust seal |
| 40.22 | Valvola completa | Valve ass'y |
| 42.21 | Sede Valvola | Valve housing |
| 43.22 | Rondella | Washer |
| 44.22 | Guarnizione | Gasket |
| 44.23 | Ammortizzatore Sup | Upper bumper |
| 44.24 | Ammortizzatore Inf | Lower bumper |
| 45.21 | Anello valvola | Ring |
| 50.24 | Pulsante completo | Trigger valve ass'y |
| 51.23 | Boccola pulsante | Trigger valve housing |
| 53.22 | Pistone servovalvola | Valve piston |
| 53.24 | Pistone servovalvola | Valve piston |
| 54.41 | Pulsante | Trigger valve |
| 55.41 | Raccordo pulsante | Bush |
| 68.22 | Distanziale rondella | Pacer |
| 69.20 | Gruppo ganascia | Jaw kit |
| 69.21 | Ribattitore | Riveter |
| 71.21.1 | Reggicaricatore | Support |
| 72.21 | Fermo carrello | Slider-Stop |
| 74.22 | Staffa | Hanger |
| 76.04 | Perno | Pin |
| 76.05 | Perno | Pin |
| 76.45 | Perno carter | Pin |
| 77.44 | Guida sicura | Safety guide |
| 80.08 | Grilletto chiusura | Trigger |
| 81.40.2 | Grilletto comando | Trigger |
| 81.42 | Controgrilletto | Trigger safety |
| 90.07 | Molla carter | Spring |
| 90.10 | Molla | Spring |
| 91.22 | Molla | Spring |
| 91.73 | Molla | Spring |
| 92.01X | Molla | Spring |
| 93.07 | Molla | Spring |
| 21.20.88 | Battente | Driver |
| 53.05.88 | Caricatore | Magazine |
| 60.22.88 | Carrello | Slider |
| 70.00.45 | Spingipunto | Pusher |
| 82.20.40 | Controtestina | Nose |
| 90.22.88 | Testina | Nose plate |
| D01 | Bocchetta olio | Oiler |

- Kit O-Rings - O-ringen - Pakninger - Guarnizioni - O-Rings - Dichtungen - Joints - Kit O-Rings -

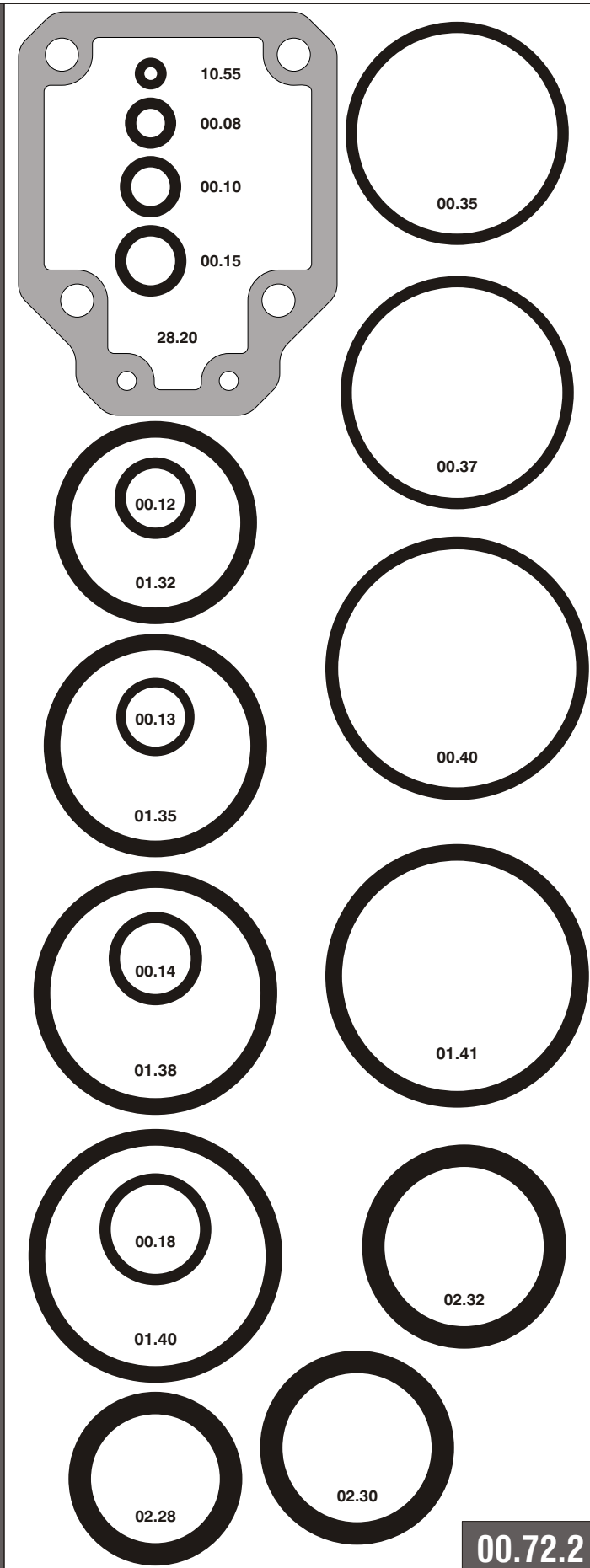

12166510_PL 88SJ_1_100510_IV

PL 88 SJ cod. 12166510

Indice di modifica
Upgrade number

1

1133723