

Caricamento - Loading

Caricamento da sotto Bottom load magazine

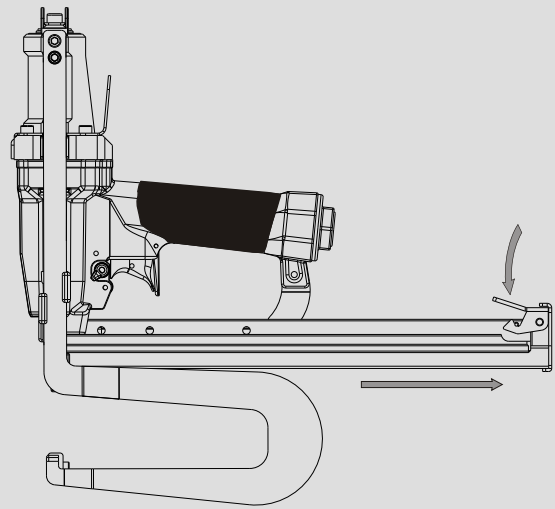

- Capovolgere la graffatrice
Turn the tool up side down
- Inserire le graffe
Load the magazine with staples
- Chiudere il carrello
Shut the slider

- Premere il grilletto chiusura
Press the magazine latch
- Arretrare il carrello
Pull the slider

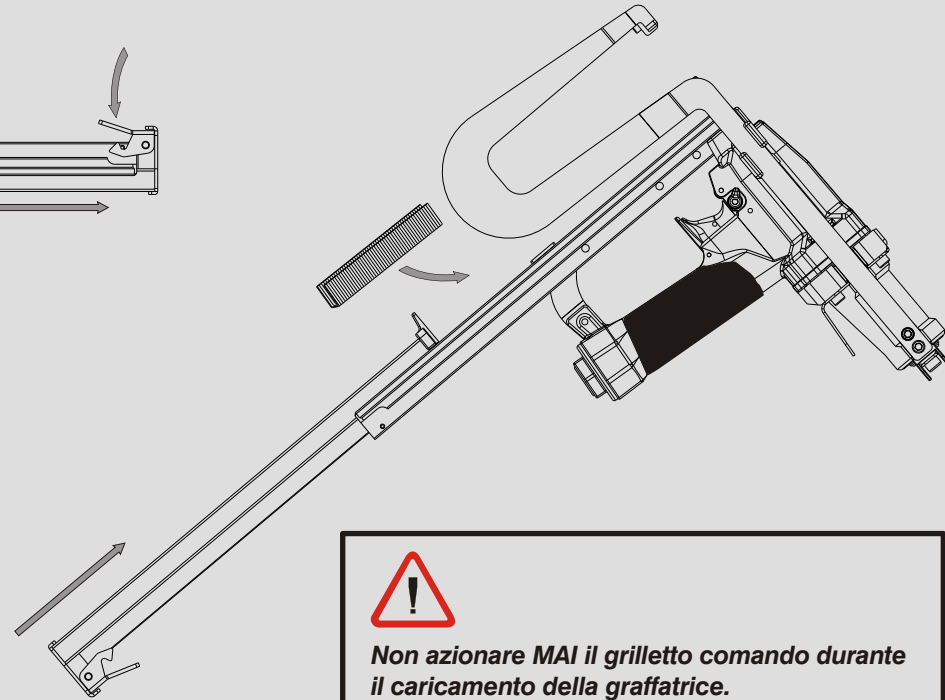

Non azionare MAI il grilletto comando durante il caricamento della graffatrice.
NEVER pull the trigger while loading magazine.

Caratteristiche - Features

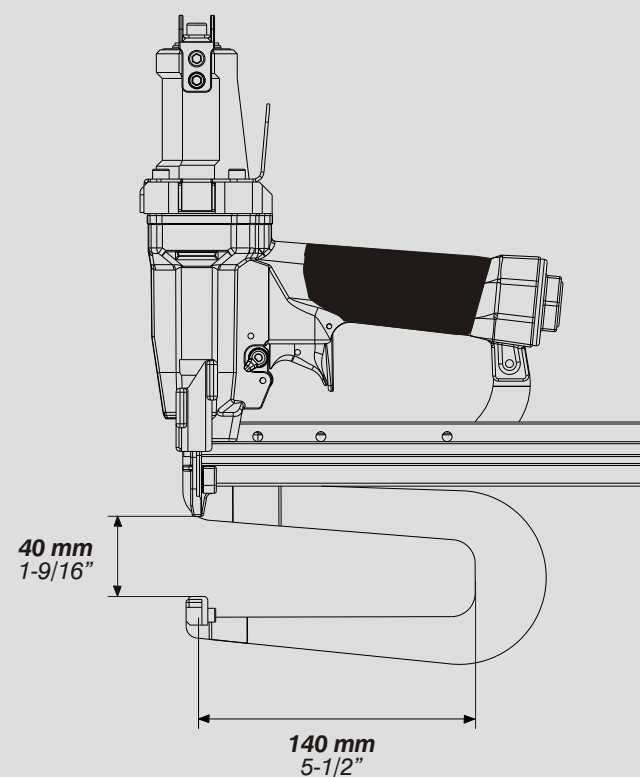

Posizione in sicura
Safety position

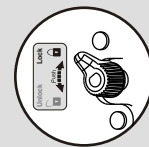

Pronta a sparare
Ready to fire



Manuale d'uso, manutenzione e parti di ricambio	Parte 2
Use, maintenance and spare parts manual	Part 2
Gebrauchsanweisung, Instandhaltungsrichtlinien und Ersatzteile	Teil 2
Manuel d'utilisation, entretien et pièces de rechange	Partie 2
Manual de uso, mantenimiento y repuestos	Part 2
Manual de utilização, manutenção e partes sobresselentes	Parte 2
Handleiding voor gebruik, onderhoud en reservedeelsite	Deel 2
Brugsanvisning, vedligeholdelse og reservedeelsite	Del 2



PL 110 LJ

cod. 12168530

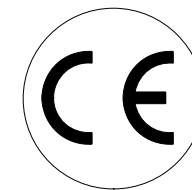

12168530_PL 110LJ_1 100510 IV

Dati tecnici Technical data Technische daten	Données techniques Datos técnicos	Dados técnicos Technischegegevens Tekniske data
--	--------------------------------------	---

Misure impiegabili mm Usable lengths mm Gebrauchliche Längen mm	Mesures utilisable mm Medidas que se pueden emplear mm	Medidas que se podem utilizar mm Te gebruiken engtes in mm Brugbare laengder i mm	12 ÷ 25
Capacità caricatore n° punti Magazine capacity No. of fasteners Magazinkapazität Nägel	Capacité chargeur n° de points Capacidad cargador n° puntos	Capacitade carregador n° pontos Capaciteit magazijn in aantal spijkers Kapacitet af magasin antal klemme	160
Pressione d'esercizio Working pressure Betriebsdruck	Pression de fonctionnement Presión de trabajo	Pressao de trabalho Werkdruk Arbejds tryk bar	5 ÷ 6,5 bar 70 ÷ 95 psi
Consumo aria litri/colpo Air consumption litres/shot Luftverbrauch Liter/Schlag	Consommation air litre/coup Consumo aire-litros/golpe	Consumo ar litro/golpe Luchtverbruik liter/schot Luftforbrug liter/skud	0,25
Peso kg Weight kg Gewicht kg	Poids kg Peso kg	Peso kg Gewicht in kg Vaegt kg	2,65
Dimensioni (AxBxH) mm Dimensions mm Größe mm	Dimension mm Dimensiones mm	Dimensoes mm Afmetingen in mm Dimensioner mm	360x70x330
EN 12549 :1999 ISO 11201 :1995	Pressione sonora in pos. operatore Sound pressure at the workstation Lärmintensität am Arbeitsplatz	Pression acoustique près de l'opérateur Presión sonora en posición encargado Lydstyrke på operatorposten	$L_{pA,1s}$ (Rif. 20µPa) 80,1 dB(A)
EN 12549 :1999 ISO 3744 :1994	Potenza sonora emessa Emitted sound power Ausgestrahlte Lärmintensität	Puissance acoustique émise Potencia sonora emitida Udsendt lydstryke	$L_{WA,1s}$ (Rif. 1pW) 86,9 dB(A)
EN 28662 :1992 ISO 5349 :1986 ISO 8662 -11	Valore medio ponderato di vibrazione sull'impugnatura Weighted mean value of vibration on the grip Mitteler Vibrationswert, am Griff Gemessen	Valeur moyenne pondérée de vibration mesurée sur la poignée Valor medio ponderado de vibracion medida en la empunadura Gewogen gemiddelde vibratiewaarde Middelvaardi af vibrationer pa handtaget	<2,5 m/s²

Tipo di punto
Type of fastener
Befestigungselement
Type d'agrafe
Tipo de punto
Tipo de ponto
Type nietjes
Tilspændingstype

110

0,60x1,60

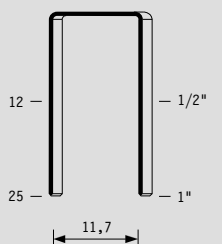

Gauge: 18
Crown: .508" (1/2")

Parti di ricambio - Spare parts - Ersatzteile - Pièces de rechange - Piezas de repuesto
- Partes sobresselentes - Tabel te raadplegen - Reservedele

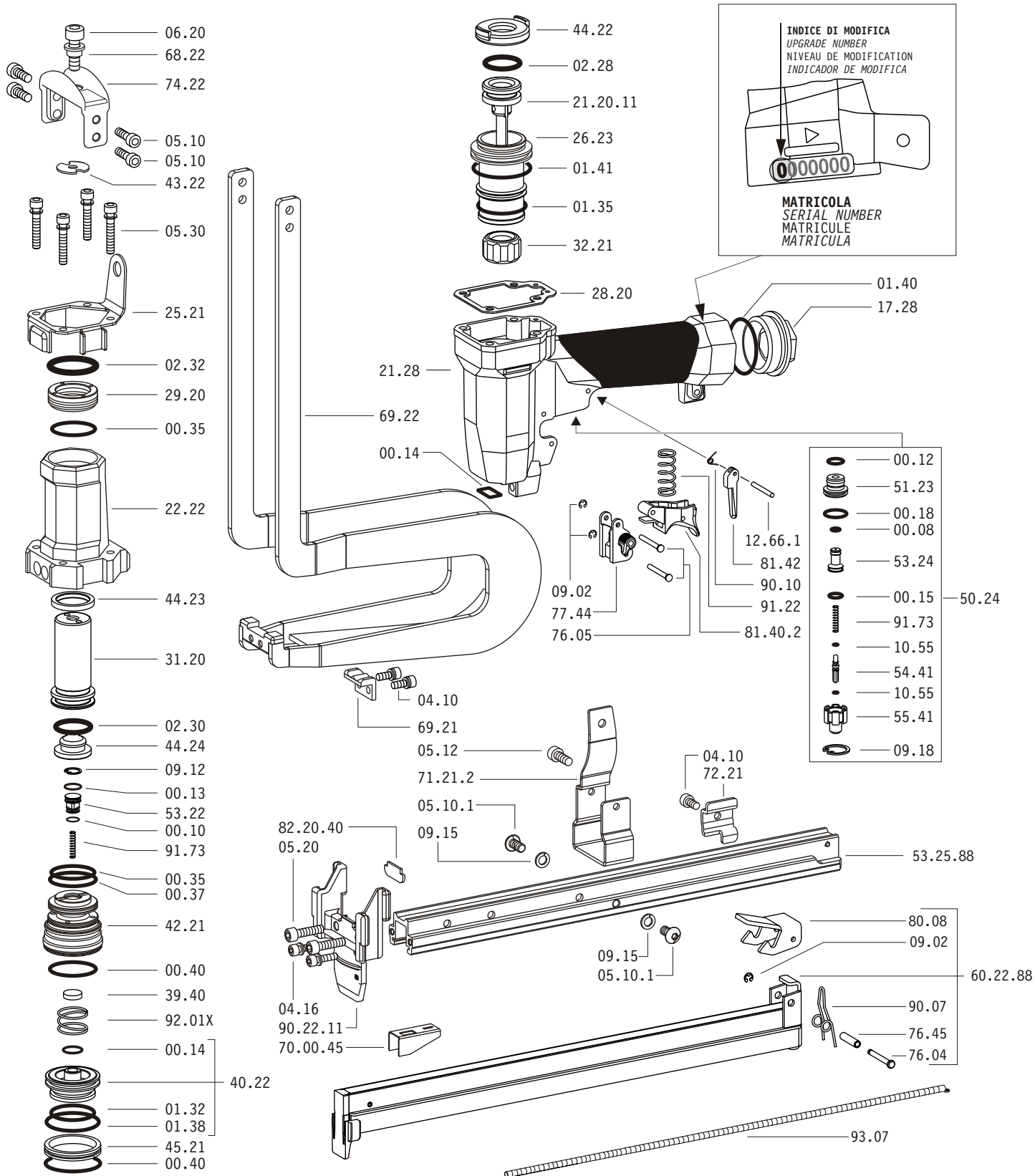

Dotazioni - Equipment - Ausrüstung - Équipements - Equipamiento - Equipamento - Uitrusting - Udstyr

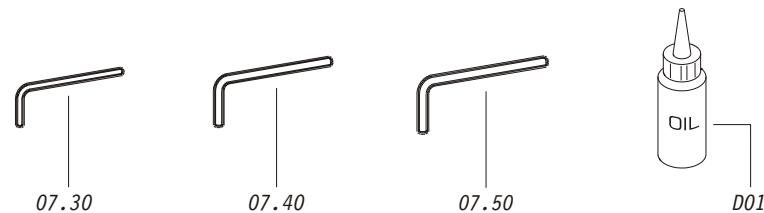

PL 110 LJ

cod. 12168530

Parti di ricambio - Spare parts - Ersatzteile - Pièces de rechange - Piezas de repuesto
- Partes sobresselentes - Tabel te raadplegen - Reservedele

Cod.	Descrizione	Description
00.08	O-Ring	O-Ring
00.10	O-Ring	O-Ring
00.12	O-Ring	O-Ring
00.13	O-Ring	O-Ring
00.14	O-Ring	O-Ring
00.15	O-Ring	O-Ring
00.18	O-Ring	O-Ring
00.35	O-Ring	O-Ring
00.37	O-Ring	O-Ring
00.40	O-Ring	O-Ring
01.32	O-Ring	O-Ring
01.35	O-Ring	O-Ring
01.38	O-Ring	O-Ring
01.40	O-Ring	O-Ring
01.41	O-Ring	O-Ring
02.28	O-Ring	O-Ring
02.30	O-Ring	O-Ring
02.32	O-Ring	O-Ring
04.10	Vite	Screw
04.16	Vite	Screw
05.10	Vite	Screw
05.10.1	Vite	Screw
05.12	Vite	Screw
05.20	Vite	Screw
05.30	Vite	Screw
06.20	Vite	Screw
07.30	Chiave esagonale	Hex. bar wrench
07.40	Chiave esagonale	Hex. bar wrench
07.50	Chiave esagonale	Hex. bar wrench
09.02	Anello elastico	Elastic ring
09.12	Anello elastico	Elastic ring
09.15	Rondella	Washer
09.18	Anello elastico	Elastic ring
10.55	O-Ring	O-Ring
12.66.1	Spina	Pin
17.28	Tappo	Inlet cap
21.28	Corpo	Body
22.22	Testa	Head
25.21	Deflettore	Exhaust deflector
26.23	Cilindro	Cylinder
28.20	Guarnizione testa	Head gasket
29.20	Bronzina	Bronze ring
31.20	Pistone Ganascia	Jaw's piston
32.21	Ammortizzatore	Bumper
39.40	Guarnizione scarico	Exhaust seal
40.22	Valvola completa	Valve ass'y
42.21	Sede Valvola	Valve housing
43.22	Rondella	Washer
44.22	Guarnizione	Gasket
44.23	Ammortizzatore Sup	Upper bumper
44.24	Ammortizzatore Inf	Lower bumper
45.21	Anello valvola	Ring
50.24	Pulsante completo	Trigger valve ass'y
51.23	Boccola pulsante	Trigger valve housing
53.22	Pistone servovalvola	Valve piston
53.24	Pistone servovalvola	Valve piston
54.41	Pulsante	Trigger valve
55.41	Raccordo pulsante	Bush
68.22	Distanziale rondella	Spacer
69.22	Gruppo ganascia	Jaw kit
69.21	Ribattitore	Riveter
71.21.2	Reggicaricatore	Support
72.21	Fermo carrello	Slider-Stop
74.22	Staffa	Hanger
76.04	Perno	Pin
76.05	Perno	Pin
76.45	Perno carter	Pin
77.44	Guida sicura	Safety guide
80.08	Grilletto chiusura	Trigger
81.40.2	Grilletto comando	Trigger
81.42	Controgrilletto	Trigger safety
90.07	Molla carter	Spring
90.10	Molla	Spring
91.22	Molla	Spring
91.73	Molla	Spring
92.01X	Molla	Spring
93.07	Molla	Spring
21.20.11	Battente	Driver
53.25.88	Caricatore	Magazine
60.22.88	Carrello	Slider
70.00.45	Spingipunto	Pusher
82.20.40	Controtestina	Nose
90.22.11	Testina	Nose plate
D01	Bocchetta olio	Oiler

-Kit O-Rings - Pakninger

Guarnizioni - O-Rings - Dichtungen - Joints - Kit O-Rings

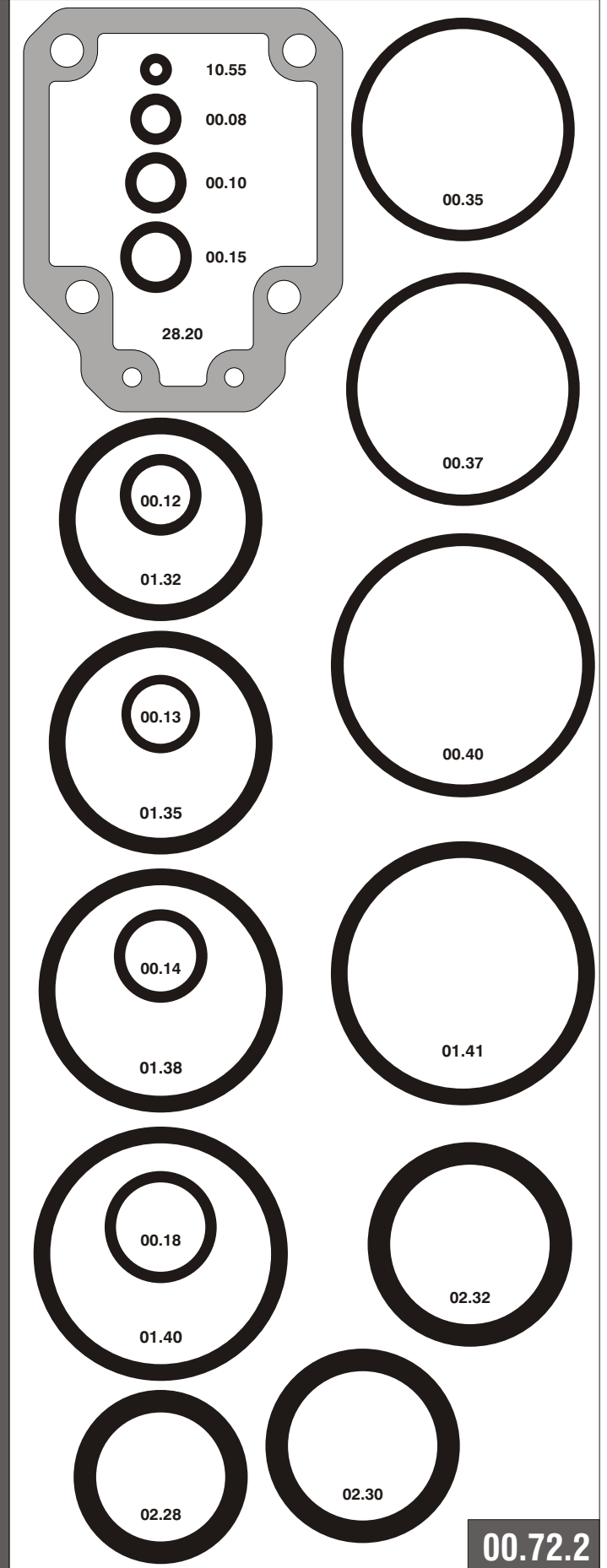

12168530_PL_110LJ_1_100510_IV

PL 110 LJ

cod. 12168530

Indice di modifica
Upgrade number

1

126244