

Caricamento - Loading

Caricamento da sotto Bottom load magazine

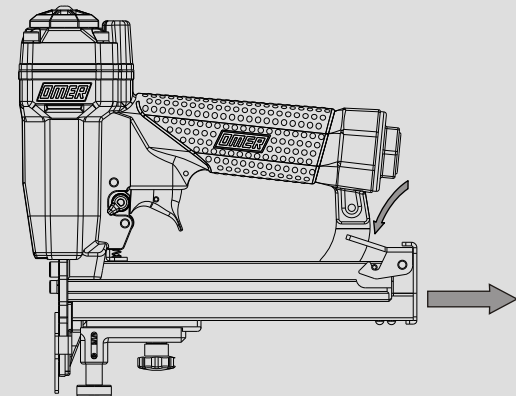

Non azionare MAI il grilletto comando o la sicura a contatto durante il caricamento della graffatrice.
NEVER pull the trigger or the contact safety while loading magazine.

- Inserire le graffe
Load the magazine with staples
- Chiudere il carrello
Shut the slider

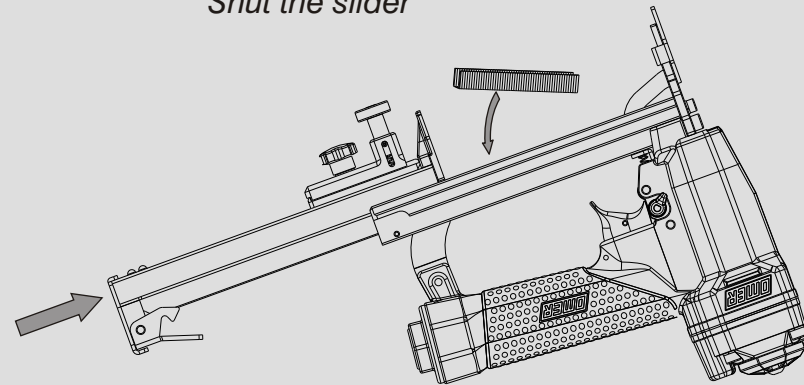

- Premere il grilletto chiusura
Press the magazine latch
- Arretrare il carrello
Pull the slider
- Capovolgere la graffatrice
Turn the tool up side down

Caratteristiche - Features

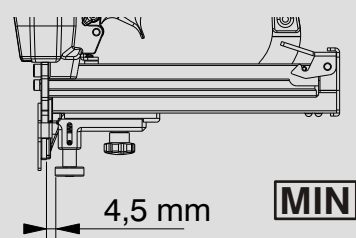

4,5 mm **MIN**

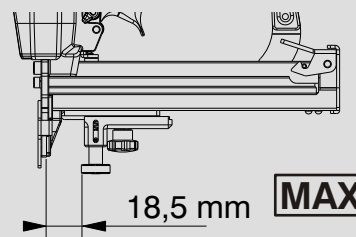

18,5 mm **MAX**

Regolazione distanziale Spacer adjusting

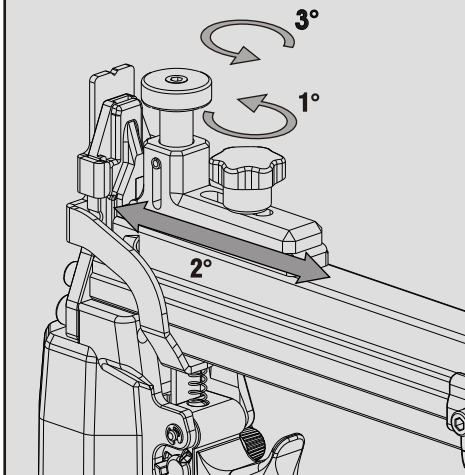

Utilizzo della macchina How to use the tool

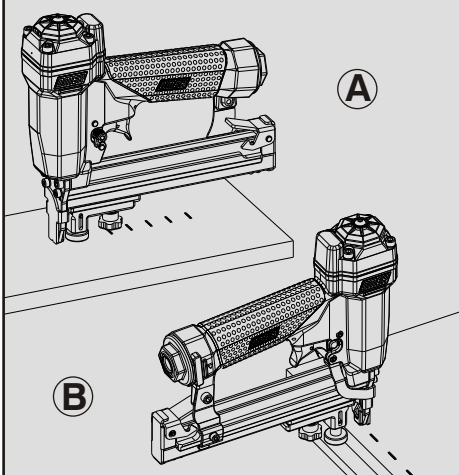

Colpo singolo Sequential fire

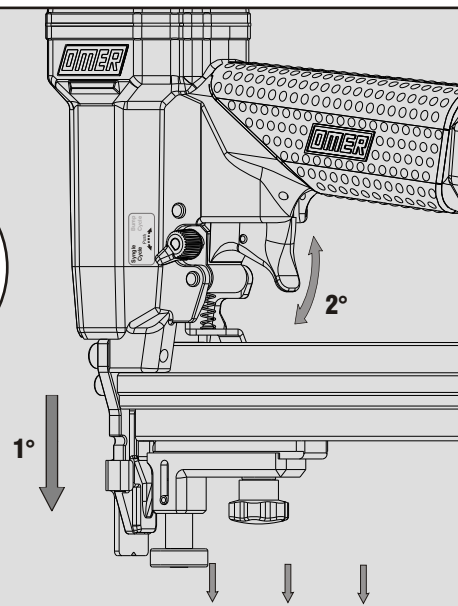
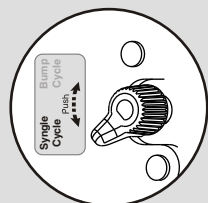

Colpo martello Bump fire

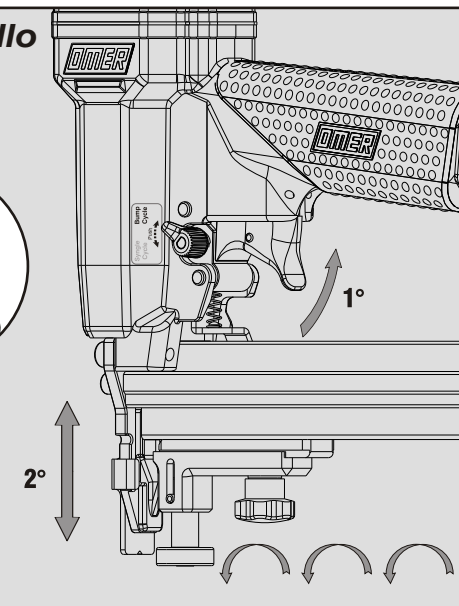
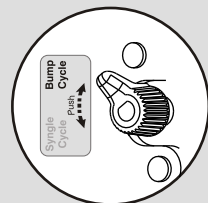

OMER

Manuale d'uso, manutenzione e parti di ricambio
Use, maintenance and spare parts manual
Gebrauchsanweisung, Instandhaltungsrichtlinien und Ersatzteile
Manuel d'utilisation, entretien et pièces de rechange
Manual de uso, mantenimiento y repuestos

Parte 2
Part 2
Teil 2
Partie 2
Part 2

Manual de utilização, manutenção e partes sobresselentes
Handleiding voor gebruik, onderhoud en reservedelslste
Brugsanvisning, vedligeholdelse og reservedelslste

Parte 2
Deel 2
Del 2



90.25 D

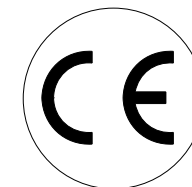

1217000D_9025D_1 070610 IV

cod. 1217000D

Dati tecnici Technical data Technische daten	Données techniques Datos técnicos	Dados técnicos Technischegegevens Teknische data
Misure impiegabili mm Usable lengths mm Gebrauchliche Längen mm	Mesures utilisables mm Medidas que se pueden emplear mm	Medidas que se podem utilizar mm Te gebruiken engtes in mm Brugbare laengder i mm
Capacità caricatore n° punti Magazine capacity No. of fasteners Magazinkapazität Nägel	Capacité chargeur n° de points Capacidad cargador n° puntos	Capacidade carregador n° pontos Capaciteit magazijn in aantal spijkers Kapacitet af magasin antal klemme
Pressione d'esercizio Working pressure Betriebsdruck	Pression de fonctionnement Presión de trabajo	Pressao de trabalho Werkdruk Arbejds tryk bar
Consumo aria litri/colpo Air consumption litres/shot Luftverbrauch Liter/Schlag	Consommation air litre/coup Consumo aire-litros/golpe	Consumo ar litro/golpe Luchtverbruik liter/schot Luftforbrug liter/skud
Peso kg Weight kg Gewicht kg	Poids kg Peso kg	Peso kg Gewicht in kg Vaegt kg
Dimensioni (AxBxH) mm Dimensions mm Größe mm	Dimension mm Dimensiones mm	Dimencoes mm Afmetingen in mm Dimensioner mm
EN 12549 :1999 ISO 11201 :1995 Pressione sonora in pos. operatore Sound pressure at the workstation Lärmintensität am Arbeitsplatz	Pression acoustique près de l'opérateur Presión sonora en posición encargada	Intensidade sonora perto do operador Geluidssterkte op de werkplek Lydstryke på operatorposten
EN 12549 :1999 ISO 3744 :1994 Potenza sonora emessa Emitted sound power Ausgestrahlte Lärmintensität	Puissance acoustique émise Potencia sonora emitida	Potência sonora emitida Uitgestraalde geluidssterkte Udsendt lydstryke
EN 28662 :1992 ISO 5349 :1986 ISO 8662 -11 Valore medio ponderato di vibrazione sull'impugnatura Weighted mean value of vibration on the grip Mittlerer Vibrationswert, am Griff Gemessen	Valeur moyenne pondérée de vibration mesurée sur la poignée Valor medio ponderado de vibracion medida en la empuñadura	Valor medio ponderado de vibracao medida no punho Gewogen gemiddelde vibratiewaarde Middelvaerdi af vibrationer pa handtaget

Tipo di punto
Type of fastener
Befestigungselement
Type d'agrafe
Tipo de punto
Tipo de ponto
Type nietjes
Tilspændingstype

90

1,00x1,25

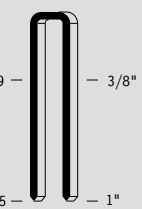

Gauge: 18
Crown: .217" (1/4")

Parti di ricambio - Spare parts - Ersatzteile - Pièces de rechange - Piezas de repuesto
- Partes sobresselentes - Tabel te raadplegen - Reservedele

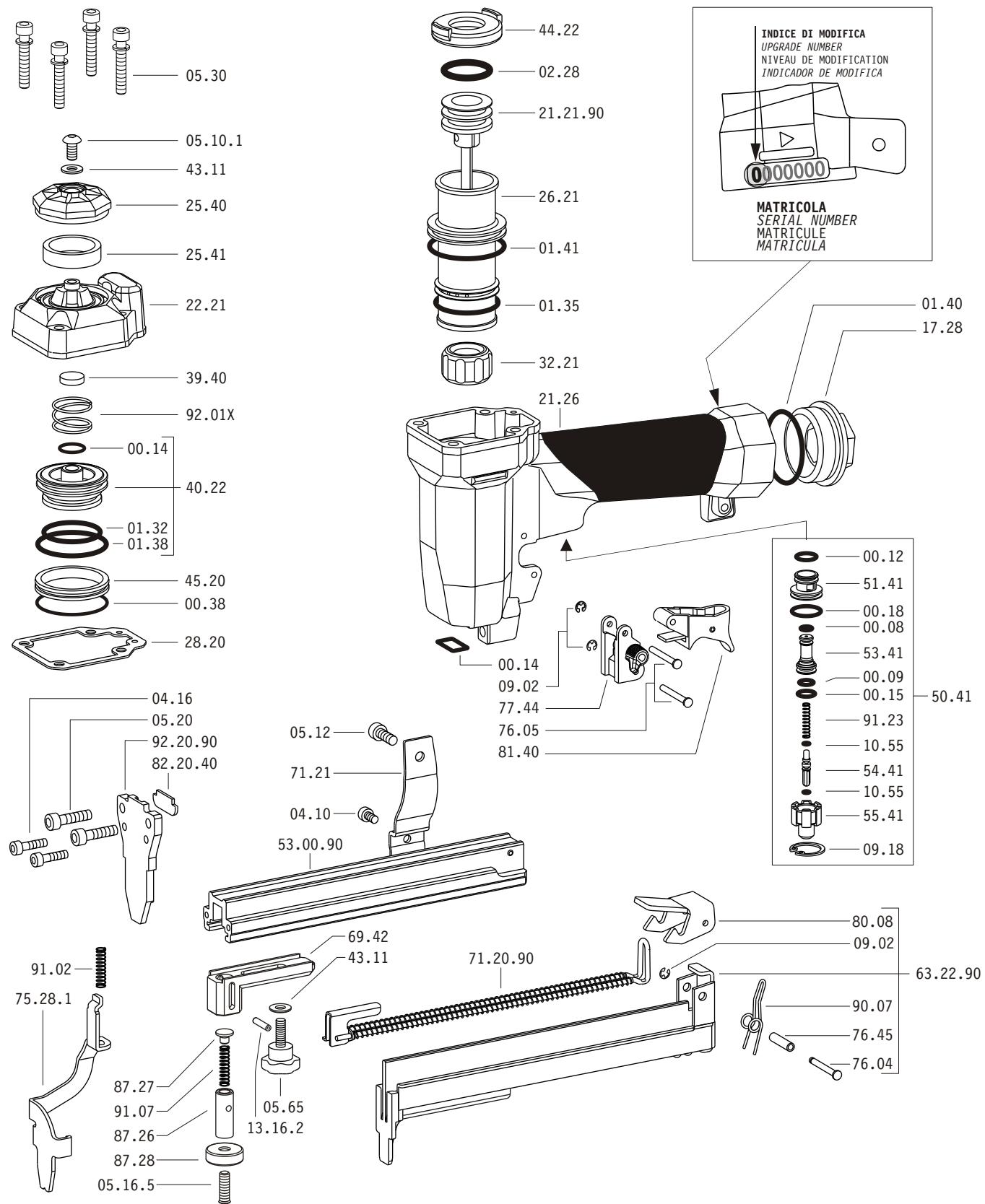

Dotazioni - Equipment - Ausrüstung - Équipements - Equipamiento - Equipamento - Uitrusting - Udstyr

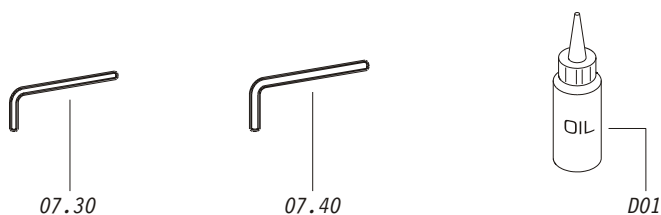

90.25 D

cod. 1217000D

Parti di ricambio - Spare parts - Ersatzteile - Pièces de rechange - Piezas de repuesto
- Partes sobresselentes - Tabel te raadplegen - Reservedele

Cod.	Descrizione	Description
00.08	O-Ring	O-Ring
00.09	O-Ring	O-Ring
00.12	O-Ring	O-Ring
00.14	O-Ring	O-Ring
00.15	O-Ring	O-Ring
00.18	O-Ring	O-Ring
00.38	O-Ring	O-Ring
01.32	O-Ring	O-Ring
01.35	O-Ring	O-Ring
01.38	O-Ring	O-Ring
01.40	O-Ring	O-Ring
01.41	O-Ring	O-Ring
02.28	O-Ring	O-Ring
04.10	Vite	Screw
04.16	Vite	Screw
05.10.1	Vite	Screw
05.16.5	Vite	Screw
05.20	Vite	Screw
05.30	Vite	Screw
05.65	Vite	Screw
07.30	Chiave esagonale	Hex. bar wrench
07.40	Chiave esagonale	Hex. bar wrench
09.02	Anello elastico	Elastic ring
09.18	Anello elastico	Elastic ring
10.55	O-Ring	O-Ring
13.16.2	Spina	Pin
17.28	Tappo	Inlet cap
21.26	Corpo	Body
22.21	Testa	Head
25.40	Deflettore	Exhaust deflector
25.41	Silenziatore	Silencer
26.21	Cilindro	Cylinder
28.20	Guarnizione testa	Head gasket
32.21	Ammortizzatore	Bumper
39.40	Guarnizione scarico	Exhaust seal
40.22	Valvola completa	Valve ass'y
43.11	Rondella	Washer
44.22	Guarnizione	Gasket
45.20	Anello valvola	Ring
50.41	Pulsante completo	Trigger valve ass'y
51.41	Boccola pulsante	Trigger valve housing
53.41	Pistone servovalvola	Valve piston
54.41	Pulsante	Trigger valve
55.41	Raccordo pulsante	Bush
69.42	Distanziatore	Spacer
71.21	Reggicaricatore	Support
75.28.1	Sicura	Safety
76.04	Perno	Pin
76.05	Perno	Pin
76.45	Perno molla	Pin
77.44	Guida sicura	Safety guide
80.08	Grilletto chiusura	Trigger
81.40	Grilletto comando	Trigger
87.26	Perno	Pin
87.27	Portamolla	Supporter
87.28	Cuscinetto	Bearing
90.07	Molla	Spring
91.02	Molla	Spring
91.07	Molla	Spring
91.23	Molla	Spring
92.01X	Molla	Spring
21.21.90	Battente	Driver
53.00.90	Caricatore	Magazine
63.22.90	Carrello	Slider
72.20.90	Spingipunto	Pusher
82.20.40	Controtestina	Nose
92.20.90	Testina	Nose plate
D01	Boccetta olio	Oiler

- Kit O-Rings - O-ringen - Pakninger

- Kit O-Rings - Dichtungen - Joints - Kit O-Rings -

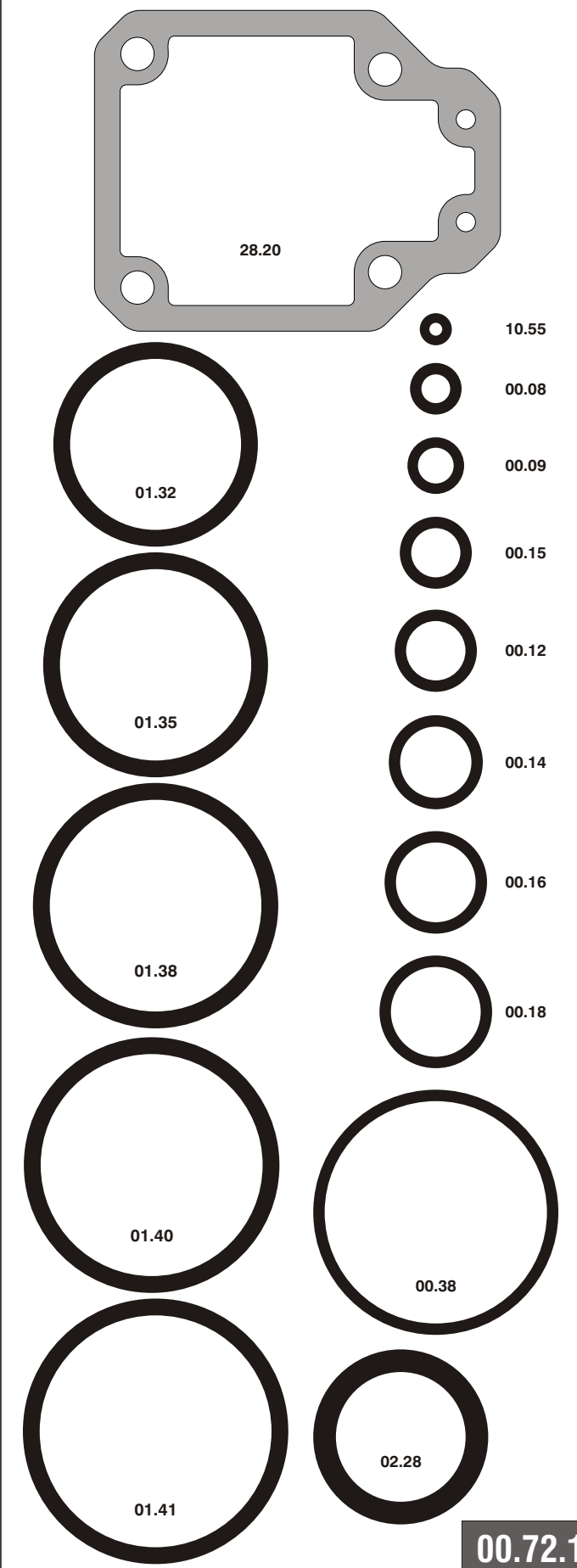

00.72.1

90.25 D

cod. 1217000D

Indice di modifica Upgrade number

1

1239685