

Schema di collegamento - Connecting diagram

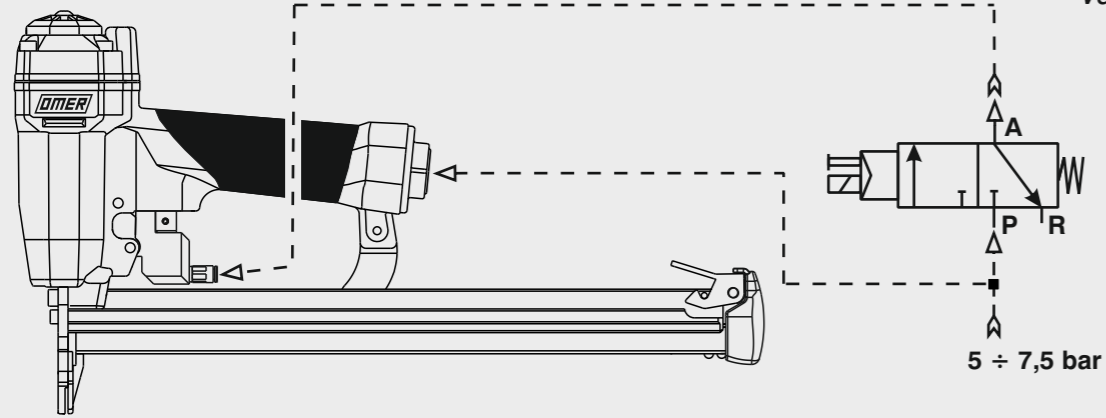

Manuale d'uso, manutenzione e parti di ricambio	Parte 2
Manual for use, maintenance and spare parts	Part 2
Bedienungs- und Wartungshandbuch sowie Ersatzteilliste	Teil 2
Mode d'emploi, de maintenance et pièces de rechange	Partie 2
Manual de uso, mantenimiento y recambios	Part 2
Εγχειρίδιο χρήσης, συντήρησης και ανταλλακτικών	Μέρος 2
Manual de uso, manutenção e peças sobresselentes	Parte 2
Handleiding voor gebruik, onderhoud en wisselstukken	Deel 2
Kullanım, bakım ve yedek parça kılavuzu	Kısım 2
Användar-, underhålls- och reservdelshandbok	Del 2

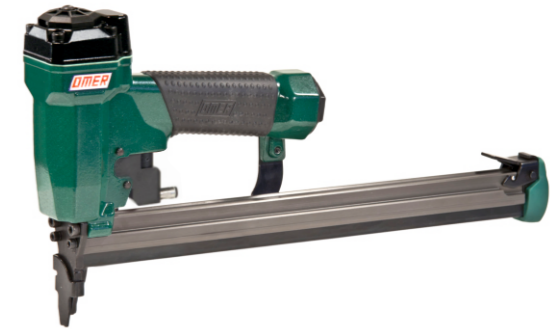

SG44.25 CL-51

cod. 1227850-51

Caricamento - Loading - Laden - Chargement - Carga - Γέμισμα - Carregamento - Laden - Yükleme - Laddning

Caricamento da sotto Bottom load magazine

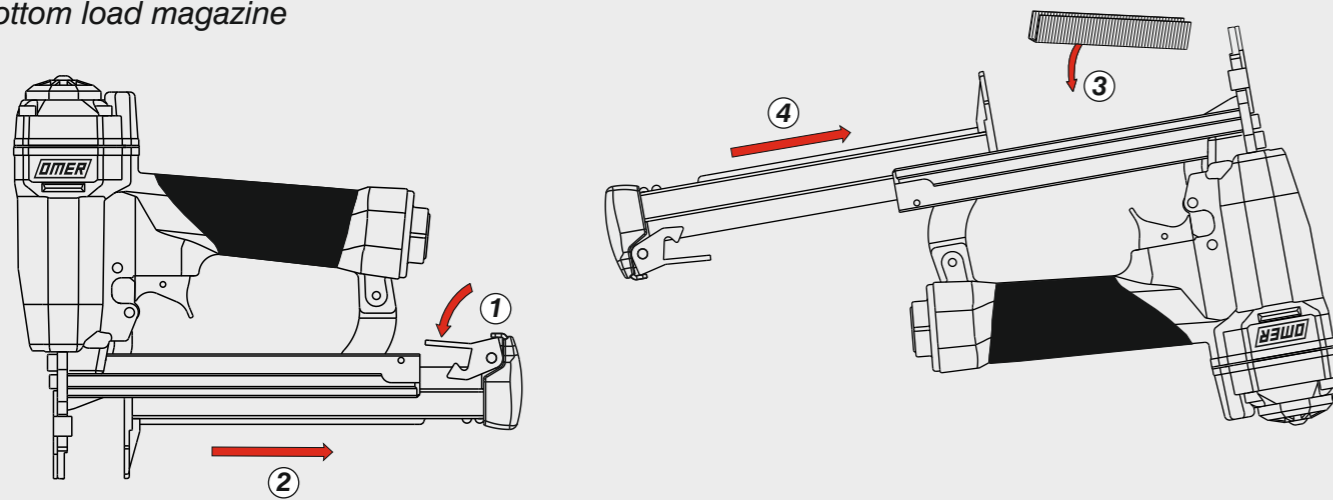

Disincernamento - Jam clearing - Staubeseitigung - Décoincement - Desatascamiento - Απεμπλοκή
Desencravamento - Deblokkering bij vastlopen - Sıkışma giderme - Rensning av igensättningar

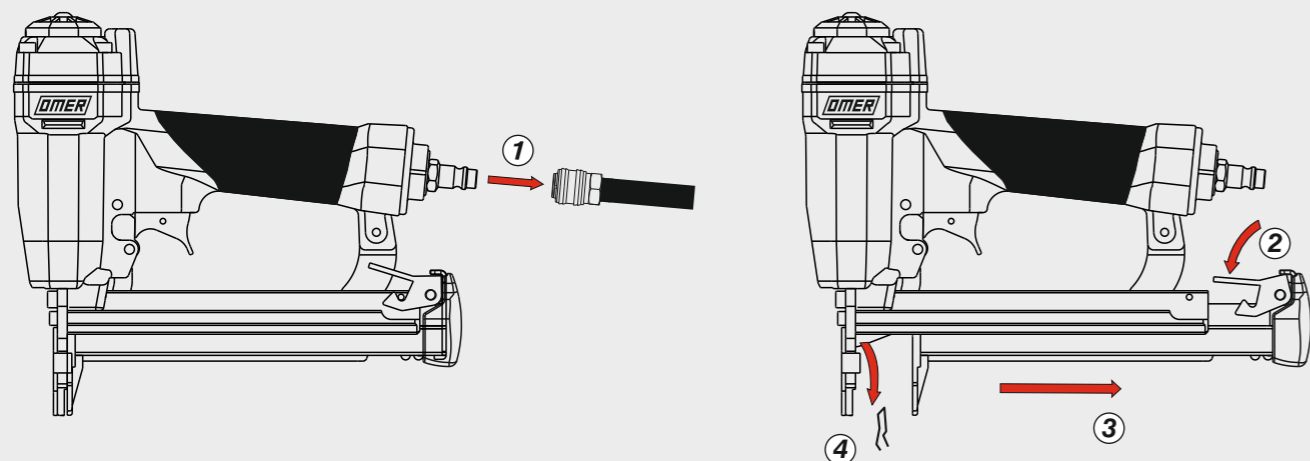

Dati tecnici

Technical data
Technische Daten
Tekniska data

Caractéristiques techniques

Datos técnicos
Τεχνικά χαρακτηριστικά

Dados técnicos

Technische gegevens
Teknik veriler

Misure impiegabili
Lengths
Verwendbare Nagellänge
Dimensioner som kan användas

Dimensions utiles
Medidas de longitud
Μήκος Αναλωσίμου

Medidas utilizáveis
Toepasbare afmetingen
Boy

mm
inch

9 ÷ 25
3/8" ÷ 1"

Capacità caricatore n° punti
Magazine capacity
Magazinkapazität: Nägel
Magasinkapacitet: Antal punkter

Capacité chargeur n° de points
Capacidad cargador n° puntos
Δυνατότητα γεμιστέρα

Capacidade carregador n° pontos
Capaciteit magazijn in aantal spijkers
Dergi kapasitesi

210

Pressione d'esercizio
Operating pressure
Betriebsdruck
Drifttryck

Pression d'exercice
Presión de servicio
Πίεση λειτουργίας

Pressão de serviço
Werkdruk
Çalışma basıncı

bar
psi

5 ÷ 7,5
70 ÷ 105

Consumo aria
Air consumption
Luftverbrauch
Luftförbrukning

Consommation d'air
Consumo aire
Κατανάλωση αέρα

Consumo ar
Luchtverbruik
Hava tüketimi

lt/colpo
ft³/cycle

0,31
0,01095

Peso
Weight
Gewicht
Vikt

Poids
Peso
Βάρος

Peso
Gewicht
Ağırlık

kg
lbs

1,49
3,28

Dimensioni
Dimensions
Abmessungen
Dimensioner (AxBxH)

Dimensions
Dimensiones
Διαστάσεις

Dimensões
Afmetingen
Boyutlar

mm
inch

359x50x211
14-1/8"x2"x8-5/16"

(LxWxH)

EN 12549 :2009 EN ISO 3746 :2011 EN ISO 4871 :2009

Potenza sonora emessa
Sound power emitted
Emittierte Schalleistung
Avgiven ljudeffekt

Puissance sonore émise
Potencia sonora emitida
Εκπεμπόμενη ηχητική ισχύς

Potência sonora emitida
Geëmitteerd geluidsvermogen
Çıkan ses gücü (ses desibeli)

dB(A)

91

(K = 4 dB)

Tipo di punto
Type of fastener
Befestigungsmittel
Type de rivet
Tipo de punto
Τύπος αναλωσίμου
Tipo de agrafó
Type nietjes
Zimba ve çivi tipleri
Typ av stygn

SG44

1,00x1,25



7,8

Crown: .386" (3/8")
Gauge: 18

**DO NOT
HANDHELD
THIS TOOL**



1227850-51_SG44.25CL-51_2_rev21_13/09/2023_DV

