



Manuale d'uso, manutenzione e parti di ricambio
Use, maintenance and spare parts manual
Gebrauchsanweisung, Instandhaltungsrichtlinien und Ersatzteile
Manuel d'utilisation, entretien et pièces de rechange
Manual de uso, mantenimiento y repuestos
Manual de utilização, manutenção e partes sobresselentes
Handleiding voor gebruik, onderhoud en reservedelste
Brugsanvisning, vedligeholdelse og reservedelsliste

Parte 2
Part 2
Teil 2
Partie 2
Part 2
 2°
Parte 2
Deel 2
Del 2



CF.15

cod. 1729600

1729600_CF15_2 270505 DVM



Dati tecnici Technical data Technische daten	Données techniques Datos técnicos	Dados técnicos Technischegegevens Teknische data
Misure impiegabili mm Usable lengths mm Gebrauchliche Längen mm	Mesures utilisable mm Medidas que se pueden emplear mm	Medidas que se podem utilizar mm Te gebruiken engtes in mm Brugbare laengder i mm
Capacità caricatore n° punti Magazine capacity No. of fasteners Magazinkapazität Nägel	Capacité chargeur n° de points Capacidad cargador n° puntos	Capacidade carregador n° pontos Capaciteit magazijn in aantal spijkers Kapacitet af magasin antal klemme
Pressione d'esercizio Working pressure Betriebsdruck	Pression de fonctionnement Presión de trabajo	Pressao de trabalho Werkdruk Arbejds tryk bar
Consumo aria litri/colpo Air consumption litres/shot Luftverbrauch Liter/Schlag	Consommation air litre/coup Consumo aire-litros/golpe	Consumo ar litro/golpe Luchtverbruik liter/schot Luftforbrug liter/skud
Peso kg Weight kg Gewicht kg	Poids kg Peso kg	Peso kg Gewicht in kg Vægt kg
Dimensioni (AxH) mm Dimensions mm Größe mm	Dimension mm Dimensiones mm	Dimencoes mm Afmetingen in mm Dimensioner mm
ISO 11201 Pressione sonora in pos. operatore Sound pressure at the workstation Lärmintensität am Arbeitsplatz	ISO 11201 Pression acoustique près de l'opérateur Presión sonora en posición encargado	ISO 11201 Intensidade sonora perto do operador Geluidssterkte op de werkplek Lydstyrke på operatorposten
ISO 3744 Potenza sonora emessa Emitted sound power Ausgestrahlte Lärmintensität	ISO 3744 Puissance acoustique émise Potencia sonora emitida	ISO 3744 Potência sonora emitida Uitgestraalde geluidssterkte Udsendt lydstryrke
ISO 5349-86 Valore medio ponderato di vibrazione sull'impugnatura max.33 colpi Weighted mean value of vibration on the grip max.33 shots Mittler Vibrationswert, am Griff gemessen max.33 Schäge	ISO 5349-86 Valeur moyenne pondérée de vibration mesurée sur la poignée max.33 coups Valor medio ponderado de vibracion medida en la empuñadura max.33 gomp	ISO 5349-86 Valor medio ponderado de vibracao medida no punho max.33 golpes Gewogen gemiddelde vibratiowaarde max.33 schot Middelvaerdi af vibrationer pa handtaget max.33 skud

Tipo di punto
Type of fastener
Befestigungselement
Type d'agrafe
Tipo de punto

Tipo de ponto
Type nietjes
Tilspændingstype

CF

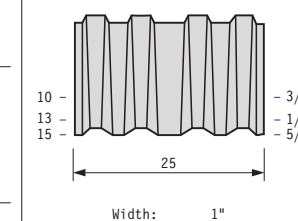

Width: 1"

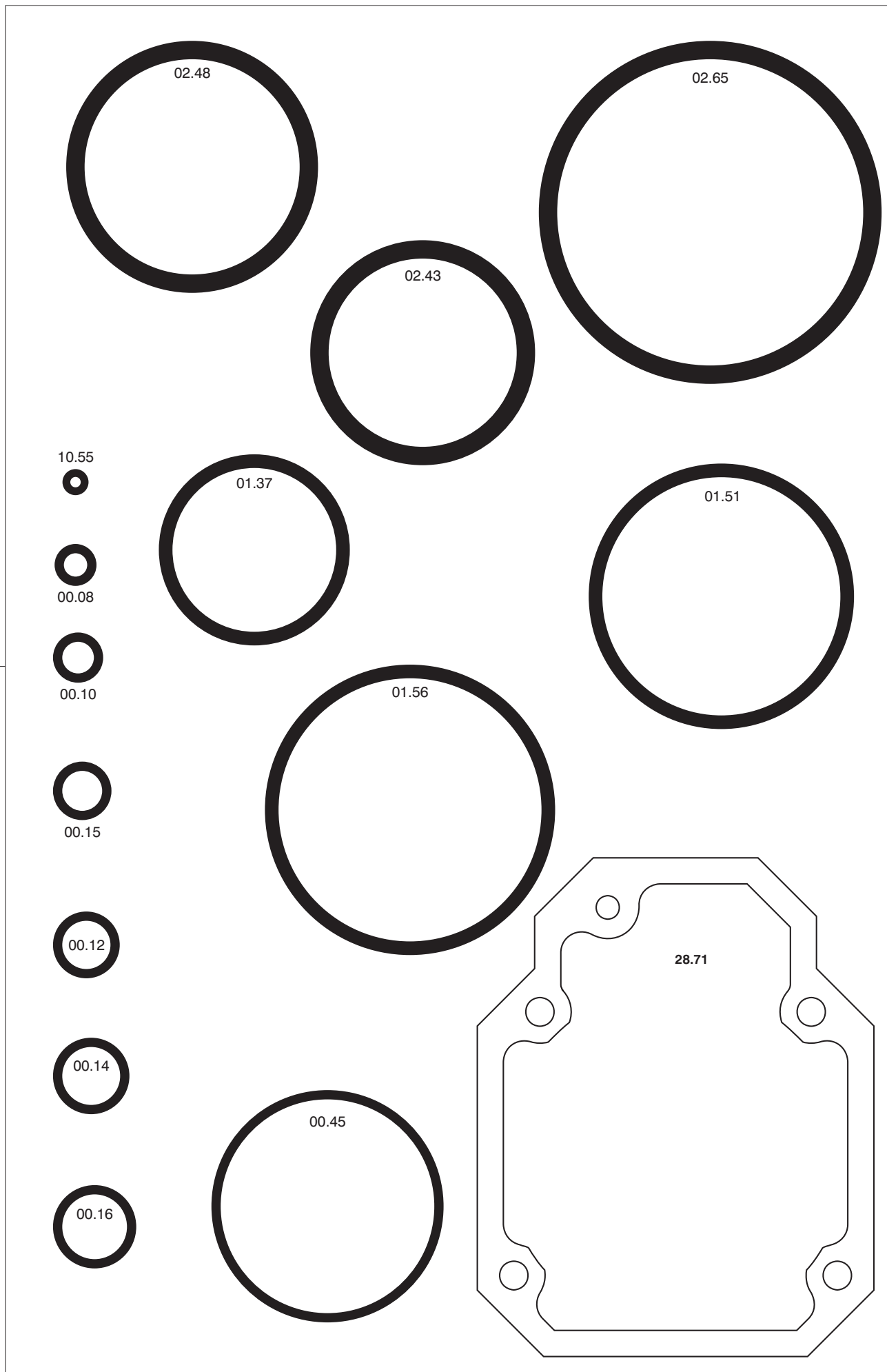

00.77.2

Parti di ricambio - Spare parts - Ersatzteile - Pièces de rechange - Piezas de repuesto
- Partes sobresselentes - Tabel te raadplegen - Reservedede

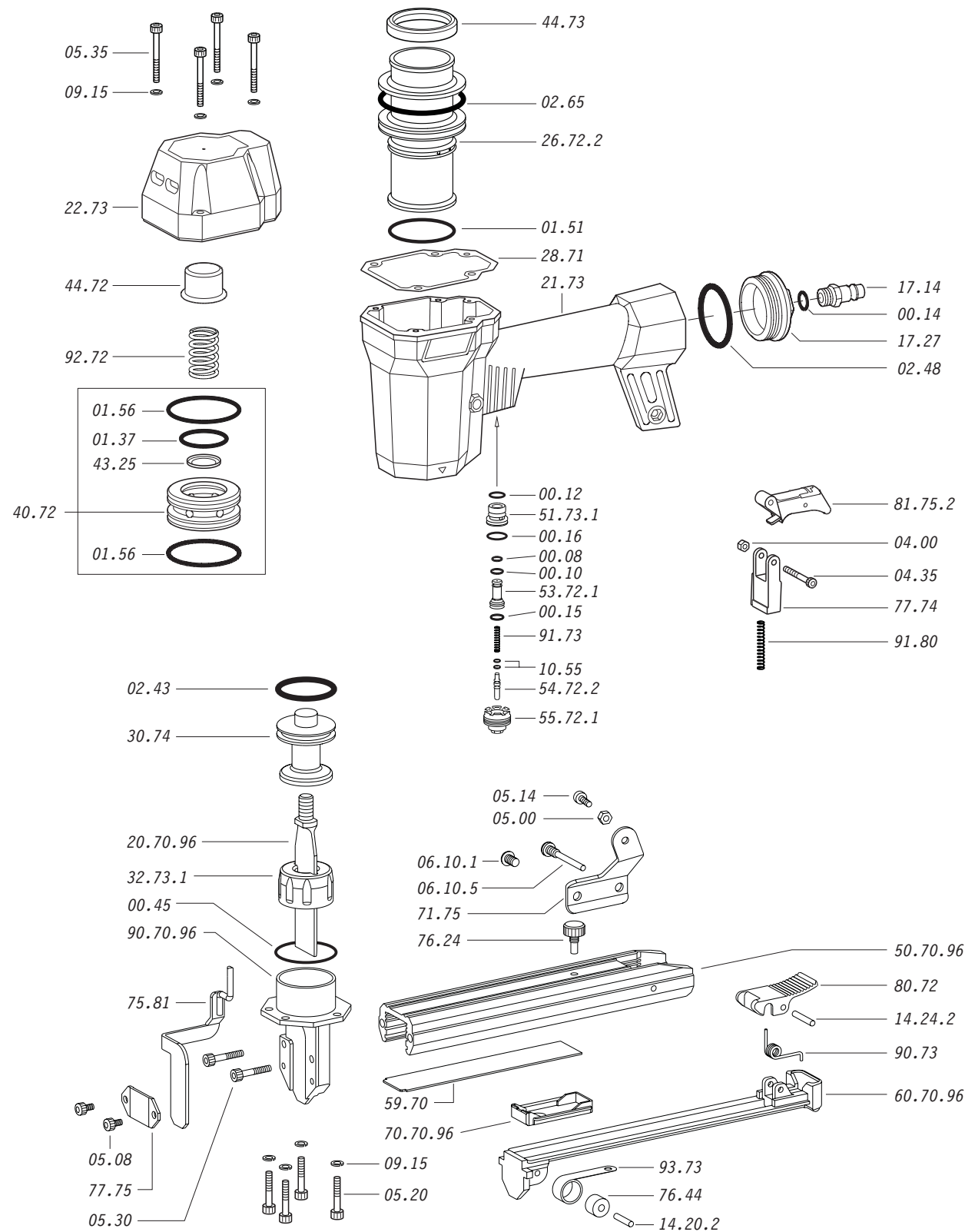

Dotazioni - Equipment - Ausrüstung - Équippements - Equipamiento - Equipamento - Uitrusting - Udstyr

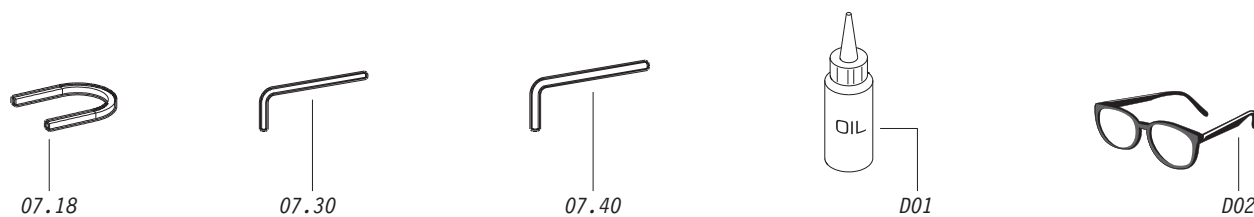

Parti di ricambio - Spare parts - Ersatzteile - Pièces de rechange - Piezas de repuesto
- Partes sobresselentes - Tabel te raadplegen - Reservedede

Cod.	Descrizione	Description
00.08	O-Ring	O-Ring
00.10	O-Ring	O-Ring
00.12	O-Ring	O-Ring
00.14	O-Ring	O-Ring
00.15	O-Ring	O-Ring
00.16	O-Ring	O-Ring
00.45	O-Ring	O-Ring
01.37	O-Ring	O-Ring
01.51	O-Ring	O-Ring
01.56	O-Ring	O-Ring
02.43	O-Ring	O-Ring
02.48	O-Ring	O-Ring
02.65	O-Ring	O-Ring
04.00	Dado	Nut
04.35	Vite	Screw
05.00	Dado	Nut
05.08	Vite	Screw
05.14	Vite	Screw
05.20	Vite	Screw
05.30	Vite	Screw
05.35	Vite	Screw
06.10.1	Vite	Screw
06.10.5	Vite	Screw
07.18	Chiave pistone	Piston wrench
07.30	Chiave esagonale	Hex. bar wrench
07.40	Chiave esagonale	Hex. Bar wrench
09.15	Rondella	Washer
10.55	O-Ring	O-Ring
14.20.2	Spina	Pin
14.24.2	Spina	Pin
17.14	Raccordo 1/4"	Air plug 1/4"
17.27	Tappo	Inlet cap
21.73	Corpo (specificare il colore)	Body (to specify the colour)
22.73	Testa	Head
26.72.2	Cilindro	Cylinder
28.71	Guarnizione testa	Head gasket
30.74	Pistone	Piston
32.73.1	Ammortizzatore	Bumper
40.72	Valvola completa	Valve assembled
43.25	Rondella	Washer
44.72	Guarnizione	Gasket
44.73	Guarnizione cilindro	Cylinder gasket
51.73.1	Cilindro servovalvola	Servo valve cylinder
53.72.1	Pistone servovalvola	Servo valve piston
54.72.2	Pulsante	Trigger valve
55.72.1	Raccordo	Trigger valve bush
59.70	Distanziale	Spacer
71.75	Reggicaricatore	Support
75.81	Sicura	Safety
76.24	Fermo distanziale	Spacer stop
76.44	Rullo molla	Roller
77.74	Guida sicura	Safety guide
77.75	Staffa sicura	Safety plate
80.72	Grilletto chiusura	Trigger
81.75.2	Grilletto comando completo	Trigger assembled
90.73	Molla	Spring
91.73	Molla	Spring
91.80	Molla	Spring
92.72	Molla	Spring
93.73	Molla	Spring
20.70.96	Battente	Driver
50.70.96	Caricatore	Magazine
60.70.96	Carrello	Slider
70.70.96	Spingipunto	Pusher
90.70.96	Testina	Nose plate
D01	Bocchetta olio	Oiler
D02	Occhiali protettivi	Protective goggles

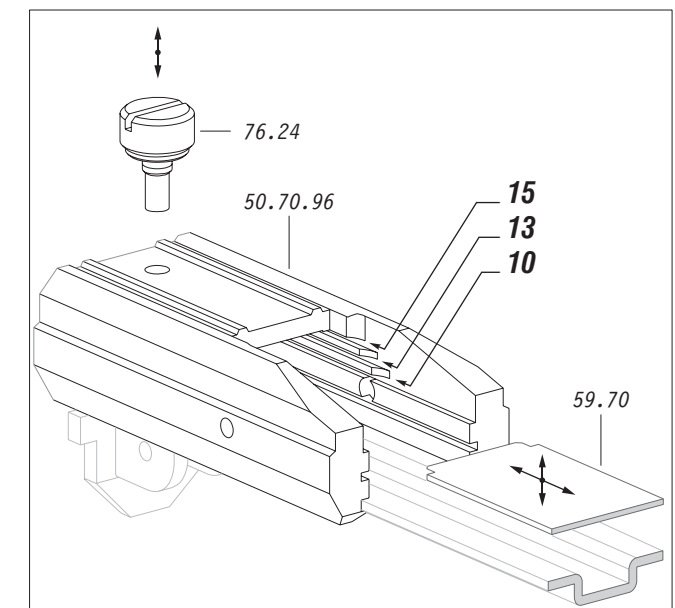
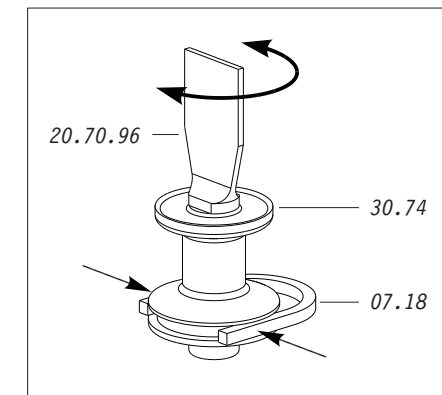

CAMBIO MISURA

- svitare il fermo distanziale (76.24)
- sfilare e riposizionare il distanziale (59.70)
- avvitare il fermo distanziale (76.24)

SIZE CHANGE

- unscrew the spacer stop (76.24)
- remove and position the spacer (59.70)
- fix the spacer stop (76.24)

1729600_CFI15.2_270505

CF.15

cod. 1729600

Indice di modifica
Upgrade number

2