

## Caratteristiche - Features

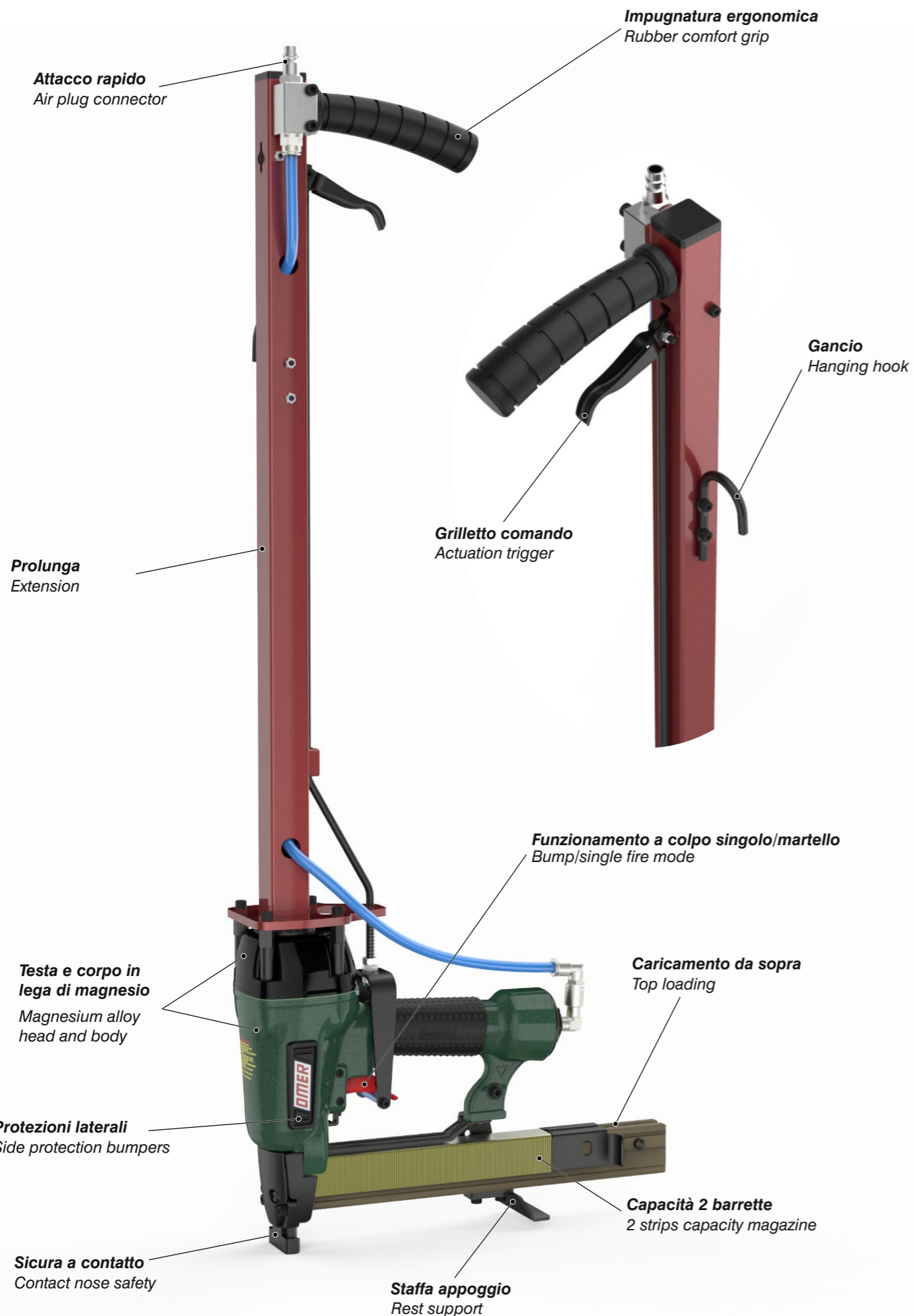

# OMER

<b>Manuale d'uso, manutenzione e parti di ricambio</b>	<b>Parte 2</b>
<b>Use, maintenance and spare parts manual</b>	<b>Part 2</b>
<b>Gebrauchsanweisung, Instandhaltungsrichtlinien und Ersatzteile</b>	<b>Teil 2</b>
<b>Manuel d'utilisation, entretien et pièces de rechange</b>	<b>Partie 2</b>
<b>Manual de uso, mantenimiento y repuestos</b>	<b>Part 2</b>
<b>Εγχειρίδιο χρήσης, συντήρησης και ανταλλακτικών</b>	<b>2<sup>ο</sup> Μέρος</b>
<b>Manual de utilização, manutenção e partes sobresselentes</b>	<b>Parte 2</b>
<b>Handleiding voor gebruik, onderhoud en reservedeelslijst</b>	<b>Deel 2</b>
<b>Brugsanvisning, vedligeholdelse og reservedeelsliste</b>	<b>Del 2</b>

1748700CP\_590738CP\_4 240413 IV

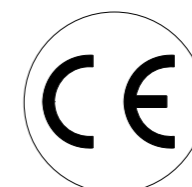

## 590.738 CP

cod. 1748700CP

Dati tecnici Technical data Technische daten	Données techniques Datos tècnicos Τεχνικά χαρακτηριστικά	Dados tècnicos Technischegegevens Tekniske data
<b>Misure impieghiabili mm</b> Usable lengths mm Gebrauchliche Längen mm	Mesures utilisables mm Medidas que se pueden emplear mm Διαστάσεις σε μμ	Medidas que se podem utilizar mm Te gebruiken engtes in mm Brugbare laengder i mm
<b>Capacità caricatore n° punti</b> Magazine capacity No. of fasteners Magazinkapazität Nägel	Capacité chargeur n° de points Capacidad cargador n° puntos Δυνατότητα γεμιστέρα, σπινδύτερος	Capacidade carregador n° pontos Capaciteit magazijn in aantal spijkers Kapacitet af magasin antal klemme
<b>Pressione d'esercizio</b> Working pressure Betriebsdruck	Pression de fonctionnement Presión de trabajo Πίεση λειτουργίας ατμ.	Pressao de trabalho Werkdruk Arbejds tryk bar
<b>Consumo aria litri/colpo</b> Air consumption litres/shot Luftverbrauch Liter/Schlag	Consommation air litre/coup Consumo aire-litros/golpe Καταναλοση αερα λ/ετῶπημα	Consumo ar litro/golpe Luchtverbruik liter/schot Luftforbrug liter/skud
<b>Peso kg</b> Weight kg Gewicht kg	Poids kg Peso kg Βαρος κγ	Peso kg Gewicht in kg Vaegt kg
<b>Dimensioni (AxBxH) mm</b> Dimensions mm Größe mm	Dimension mm Dimensiones mm Δυνατότητα γεμιστέρα, σπινδύτερος	Dimencoes mm Afmetingen in mm Dimensioner mm
<b>EN 12549 :1999 ISO 11201 :1995</b>		
<b>Pressione sonora in pos. operatore</b> Sound pressure at the workstation Lärmintensität am Arbeitsplatz	Pression acoustique près de l'opérateur Presión sonora en posición encargado Ακουστική πίεση στη θέση χειριστού	Intensidade sonora perto do operador Geluidsterkte op de werkplek Lydstyrke på operatorposten
<b>EN 12549 :1999 ISO 3744 :1994</b>		
<b>Potenza sonora emessa</b> Emitted sound power Ausgestrahlte Lärmintensität	Puissance acoustique émise Potencia sonora emitida Ακουστική ισχυ	Potência sonora emitida Uitgestraalde geluidsterkte Udsendt lydstryke
<b>EN 28662 :1992 ISO 5349 :1986 ISO 8662 -11</b>		
<b>Valore medio ponderato di vibrazione sull'impugnatura</b> Weighted mean value of vibration on the grip Mitteler Vibrationswert, am Griff Gemessen	Valeur moyenne pondérée de vibration mesurée sur la poignée Valor medio ponderado de vibracion medida en la empuñadura Μεσοσ ορος μετρησις κραδασιμον στη χειρολαβη	Valor medio ponderado de vibracao medida no punho Gewogen gemiddelde vibratiewaarde Middelvaardi af vibrationer pa handtaget

Tipo di punto  
Type of fastener  
Befestigungselement  
Type d'agrafe  
Tipo de punto  
Τυπος κῶρφιου  
Tipo de ponto  
Type nietjes  
Tilspændingstype

590

0,85x1,80

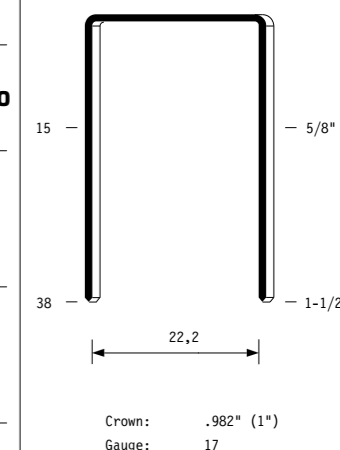

Parti di ricambio - Spare parts - Ersatzteile - Pièces de rechange - Piezas de repuesto  
 Ανταλλακτικά - Partes sobresselentes - Tabel te raadplegen - Reservedede

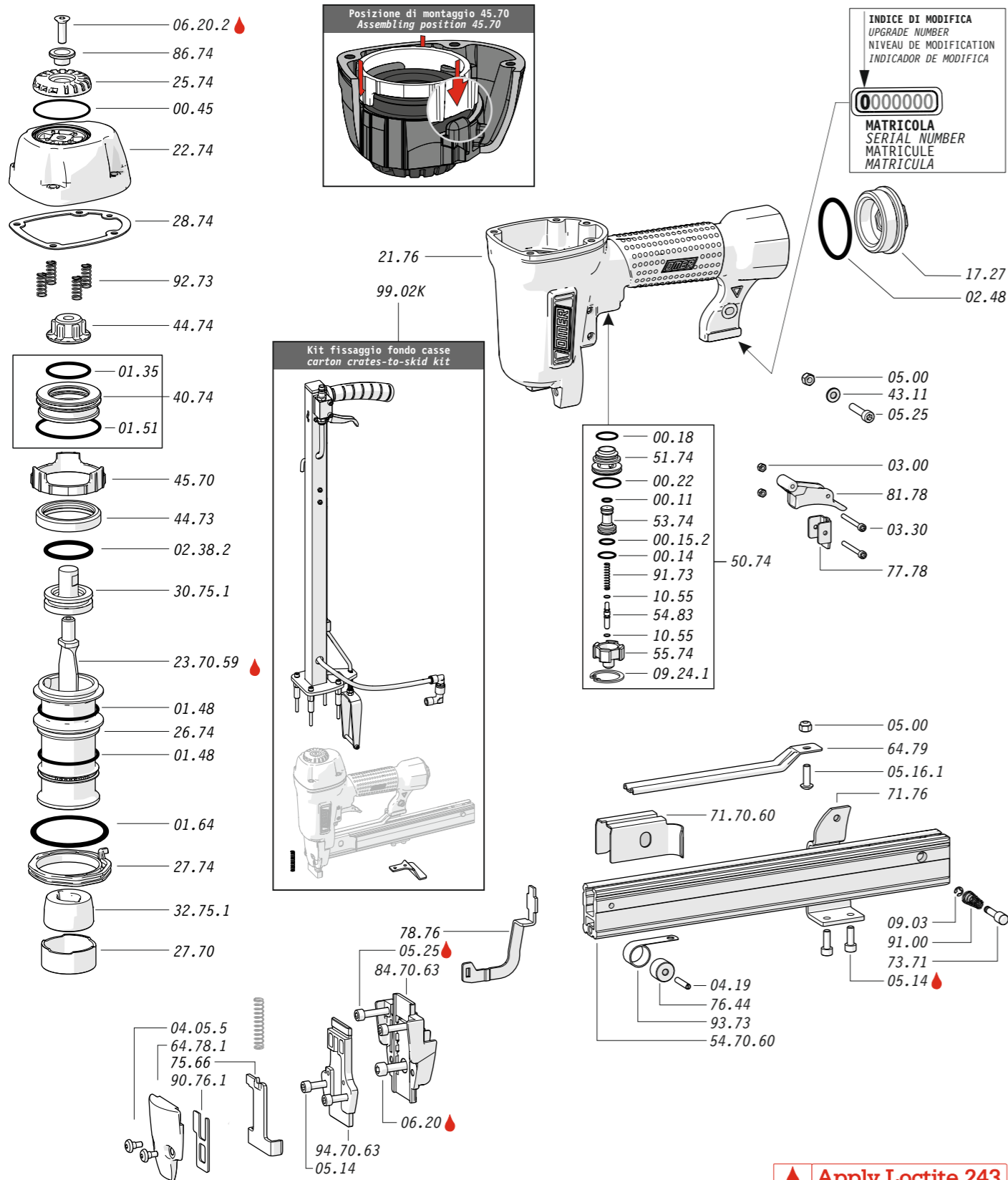

Dotazioni - Equipment - Ausrüstung - Équipements - Equipamiento - Παρεχόμενα  
 Equipamento - Uitrusting - Udstyr

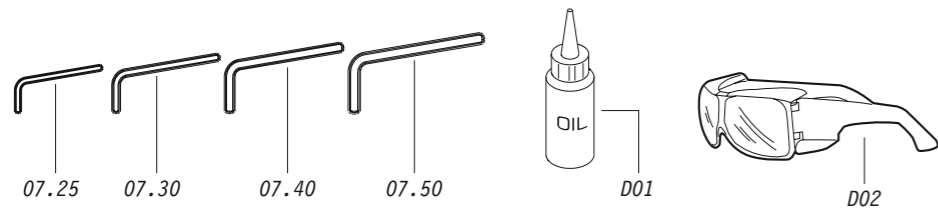

590.738 CP

cod. 1748700CP

Disinceppamento - Jam clearing

**⚠** Scollegare la chiodatrice dall'impianto durante le operazioni di disinceppamento.  
 Disconnect the tool from air supply while clearing a jam and maintenance.

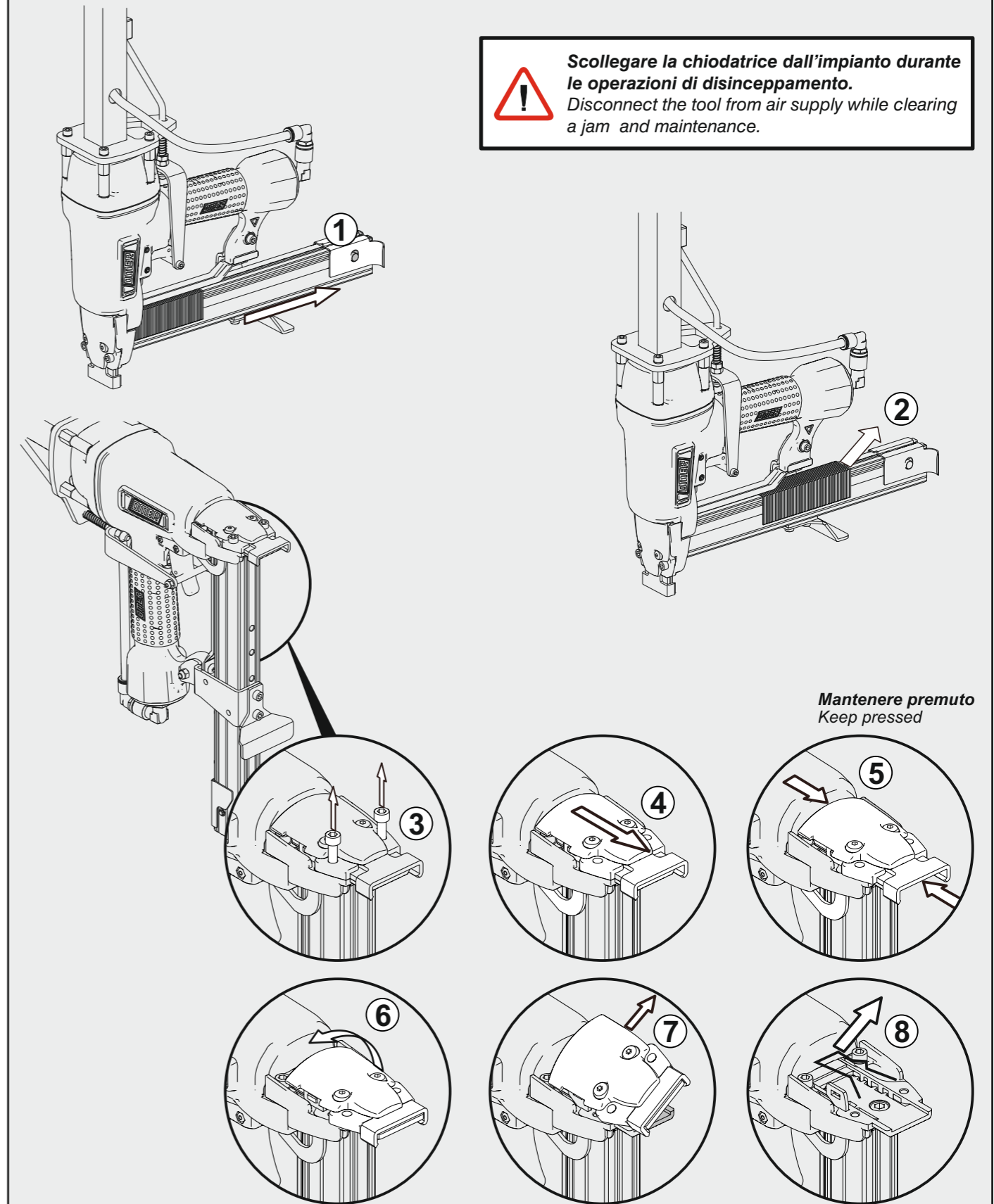

7

Riassemblare in ordine inverso



Reassemble in reverse order

1



## Caricamento - Loading

- 1- Arretrare lo spingipunto e agganciarlo al finecorsa**  
Pull the pusher backwards and lock it at the stop position at the end of the magazine

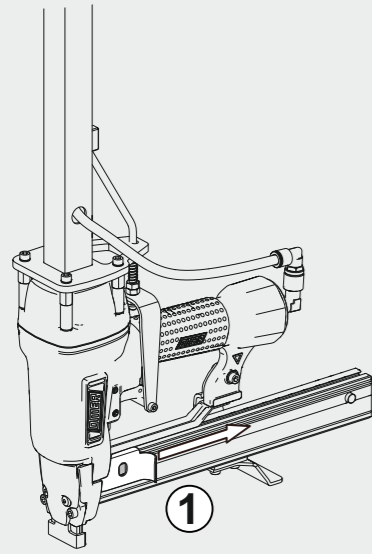

- 2- Inserire le graffe**  
Load the magazine with staples

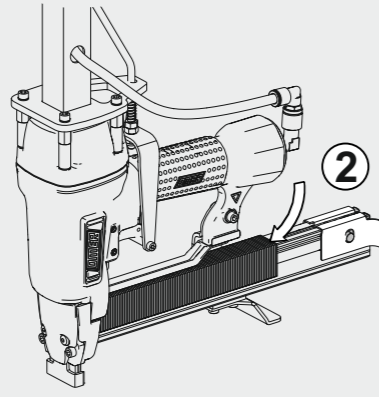

- 3- Rilasciare lo spingipunto**  
Release the pusher

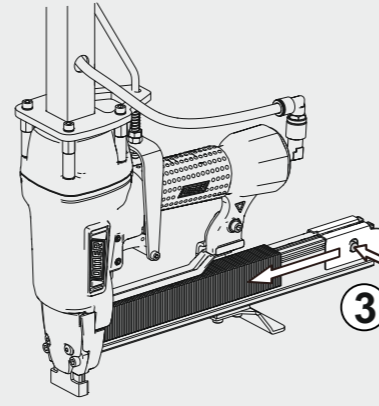

**Non azionare MAI il grilletto comando o la sicura a contatto durante il caricamento.**  
**NEVER actuate the trigger or the contact safety while loading.**

## Funzionamento - Operating mode

### Colpo martello Bump fire

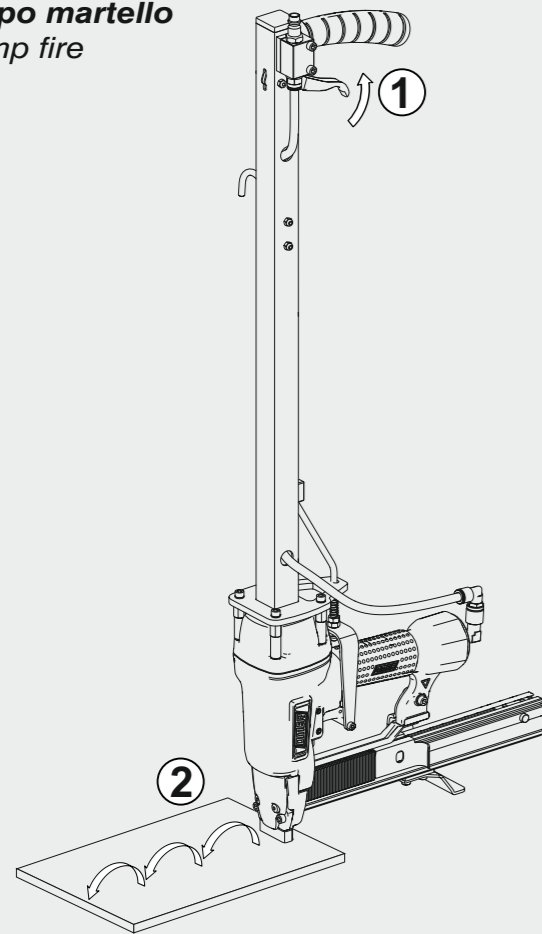

- 1- Premere il grilletto e mantenerlo premuto.**  
Press and keep holding the trigger.
- 2- Premere la sicura sul materiale da fissare per sparare.**  
Press the safety against the material to be fastened to fire.

### Colpo singolo Single fire

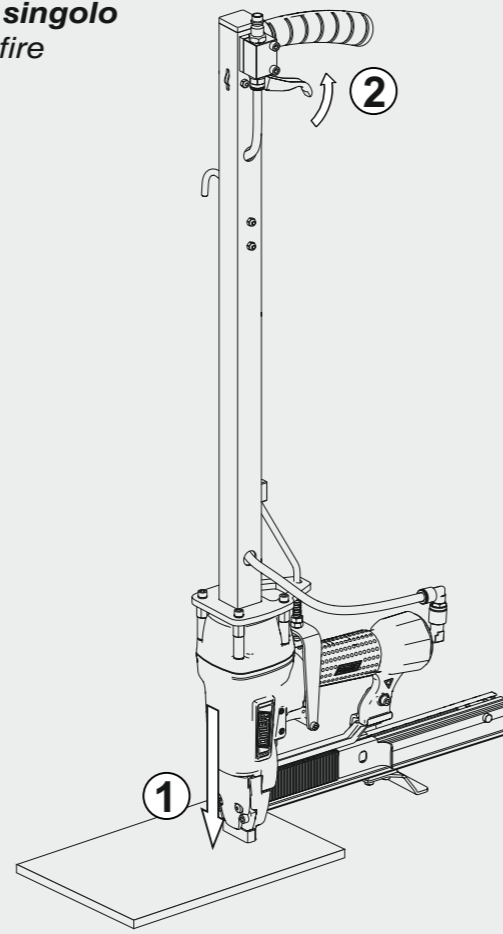

- 1- Premere la sicura sul materiale da fissare.**  
Press the safety against the material to be fastened.
- 2- Premere il grilletto per sparare.**  
Press the trigger to fire.

## Parti di ricambio - Spare parts - Ersatzteile - Pièces de rechange - Piezas de repuesto Ανταλλακτικά - Partes sobresselentes - Tabel te raadplegen - Reservedele

Cod.	Descrizione	Description
00.11	O-Ring	O-Ring
00.14	O-Ring	O-Ring
00.15.2	O-Ring	O-Ring
00.18	O-Ring	O-Ring
00.22	O-Ring	O-Ring
00.45	O-Ring	O-Ring
01.35	O-Ring	O-Ring
01.48	O-Ring	O-Ring
01.51	O-Ring	O-Ring
01.64	O-Ring	O-Ring
02.38.2	O-Ring	O-Ring
02.48	O-Ring	O-Ring
03.00	Dado	Nut
03.30	Dado	Nut
04.05.5	Vite	Screw
04.19	Vite	Screw
05.00	Dado	Nut
05.14	Vite	Screw
05.16.1	Vite	Screw
05.25	Vite	Screw
06.20	Vite	Screw
06.20.2	Vite	Screw
07.25	Chiave esagonale	Hex. bar wrench
07.30	Chiave esagonale	Hex. bar wrench
07.40	Chiave esagonale	Hex. bar wrench
07.50	Chiave esagonale	Hex. bar wrench
09.03	Anello elastico	Elastic ring
09.24.1	Anello elastico	Elastic ring
10.55	O-Ring	O-Ring
17.27	Tappo	Inlet cap
21.76	Corpo	Body
22.74	Testa	Head
25.74	Deflettore scarico	Exhaust deflector
26.74	Cilindro	Cylinder
27.70	Anello	Ring
27.74	Anello cilindro	Cylinder ring
28.74	Guarnizione testa	Head gasket
30.75.1	Pistone	Piston
32.75.1	Ammortizzatore	Bumper
40.74	Valvola completa	Valve assembled
43.11	Rondella	Washer
44.73	Guarnizione cilindro	Cylinder gasket
44.74	Ammortizzatore sup.	Upper bumper
45.70	Distanziale	Spacer
50.74	Pulsante completo	Trigger valve assy
51.74	Boccola servovalvola	Servo valve bushing
53.74	Pistone servovalvola	Servo valve piston
54.83	Pulsante	Trigger valve
55.74	Raccordo pulsante	Trigger valve bush
64.78.1	Carter sicura	Safety guard
64.79	Carter	Hold down
71.76	Reggicaricatore	Support
73.71	Perno	Pin
75.66	Sicura	Safety
76.44	Rullo molla	Roller
77.78	Guida sicura	Safety guide
78.76	Staffa sicura	Safety rod
81.78	Grilletto comando BF	BF Trigger
86.74	Boccola	Bushing
90.76.1	Piastra	Plate
91.00	Molla	Spring
91.73	Molla	Spring
92.73	Molla	Spring
93.73	Molla	Spring
99.02K	Kit fissaggio fondi casse	Crates-to-skid Kit
23.70.59	Battente	Driver
52.70.60	Caricatore	Magazine
73.70.60	Spingipunto	Pusher
84.70.63	Controtestina	Nose
94.70.63	Testina	Nose plate
D01	Bocchetta olio	Oiler
D02	Occhiali protettivi	Protective goggles

Guarnizioni - O-Rings - Dichtungen - Joints - Kit O-Rings - Αρστυρακια - Kit O-Rings - O-ringen - Pakninger

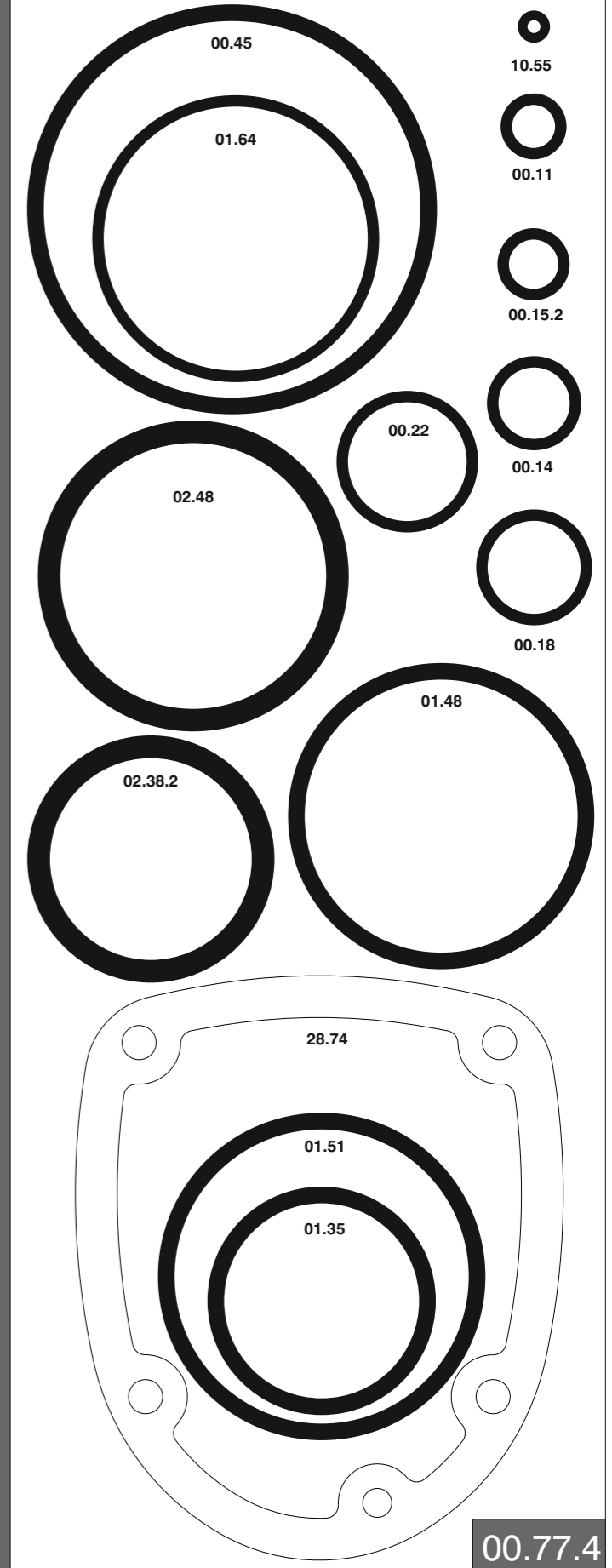

1748700CP\_590738CP\_4\_240413\_IV

**590.738 CP**

cod. 1748700CP

Indice di modifica  
Upgrade number

**4**

4316525

Parti di ricambio - Spare parts - Ersatzteile - Pièces de rechange - Piezas de repuesto  
Ανταλλακτικά - Partes sobresselentes - Tabel te raadplegen - Reservedele

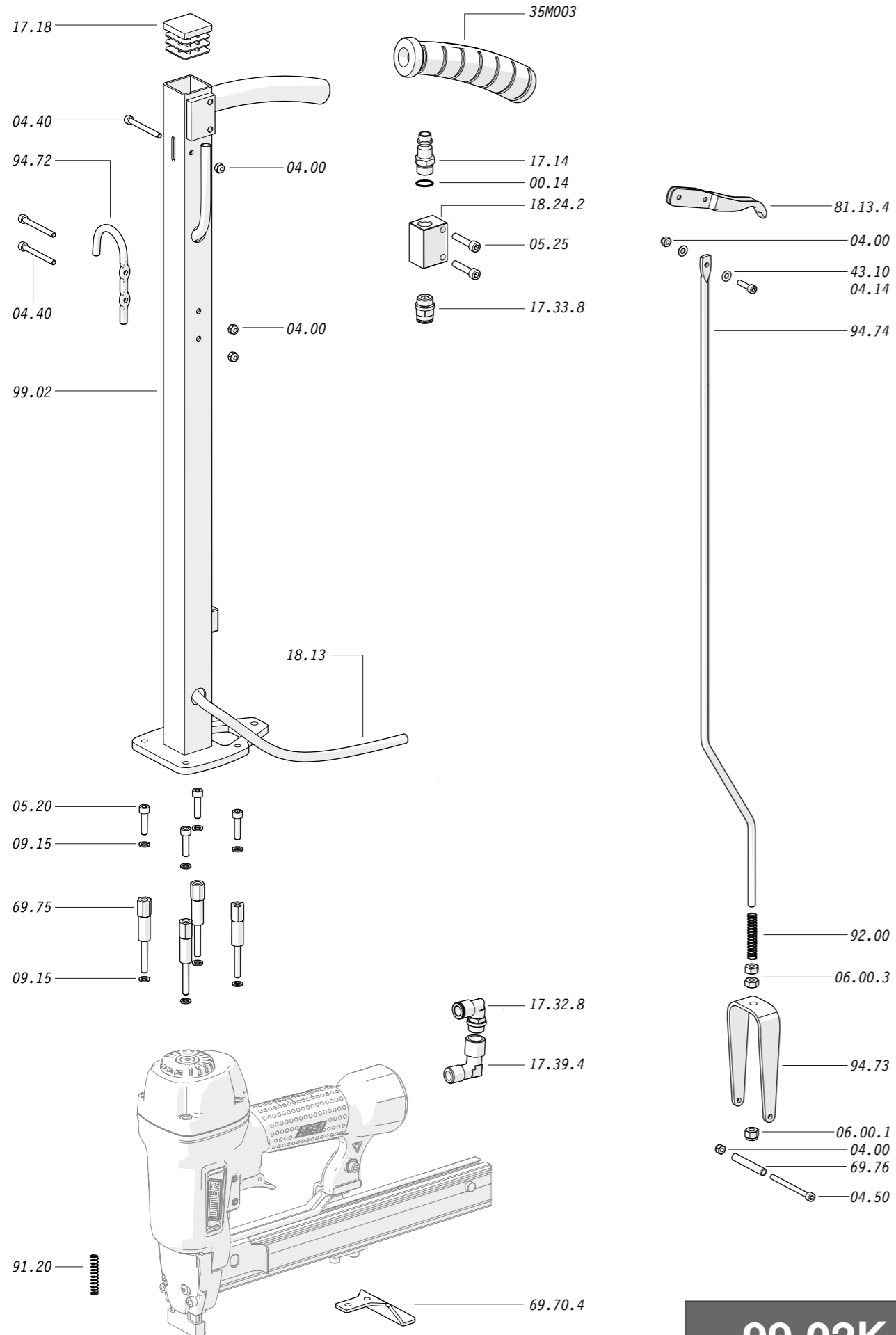

99.02K

Parti di ricambio - Spare parts - Ersatzteile - Pièces de rechange - Piezas de repuesto  
Ανταλλακτικά - Partes sobresselentes - Tabel te raadplegen - Reservedele

Cod.	Descrizione	Description
00.14	O-Ring	O-Ring
04.00	Vite	Screw
04.14	Vite	Screw
04.40	Vite	Screw
04.50	Vite	Screw
05.20	Vite	Screw
05.25	Vite	Screw
06.00.1	Dado	Nut
06.00.3	Dado	Nut
09.15	Rondella	Washer
17.14	Attacco rapido	Air plug
17.18	Tappo	Inlet cap
17.32.8	Raccordo "L"	Connection "Elbow"
17.33.8	Raccordo "D"	Connection "Straight"
17.39.4	Raccordo "L"	Connection "Elbow"
18.24.2	Distributore	Distributor
18.13	Tube	Tube
43.10Z	Rondella	Washer
69.70.4	Staffa appoggio	Rest support
69.75	Vite-distanziale	Spacer-screw
69.76	Distanziale	Spacer
81.13.4	Grilletto	Trigger
91.20	Molla	Spring
92.00	Molla	Spring
94.72	Gancio	Hook
94.73	Forcella	Fork
94.74	Tirante	Rod
99.02	Prolunga	Extension
35M003	Impugnatura gomma	Rubber grip

Dati tecnici - Technical data

