

Tabella distanziali - Spacer table

H: 11 mm 7/16"		H: 17 mm 11/16"		H: 21 mm 27/32"		H: 27 mm 1-3/32"	
L	S	L	S	L	S	L	S
18 mm 11/16"	6 ÷ 10 mm 1/4" ÷ 3/8"	22 mm 7/8"	11 ÷ 16 mm 7/16" ÷ 5/8"	25 mm 1"	15 ÷ 18 mm 5/8" ÷ 11/16"	32 mm 1 1/4"	21 ÷ 24 mm 13/16" ÷ 15/16"
20 mm 13/16"	6 ÷ 10 mm 1/4" ÷ 3/8"	25 mm 1"	13 ÷ 16 mm 1/2" ÷ 5/8"	28 mm 1 1/8"	16 ÷ 19 mm 5/8" ÷ 3/4"	35 mm 1 1/3-8"	23 ÷ 26 mm 29/32" ÷ 1"
22 mm 7/8"	8 ÷ 10 mm 5/16" ÷ 3/8"	28 mm 1 1/8"	13 ÷ 16 mm 1/2" ÷ 5/8"	30 mm 1 1/3-16"	18 ÷ 19 mm 11/16" ÷ 3/4"	38 mm 1 1/2"	26 ÷ 27 mm 1" ÷ 1-1/16"
		30 mm 1 1/3-16"	14 ÷ 16 mm 9/16" ÷ 5/8"	32 mm 1 1/4"	20 mm 3/4"		
		32 mm 1 1/4"	16 mm 5/8"				

Caratteristiche - Features

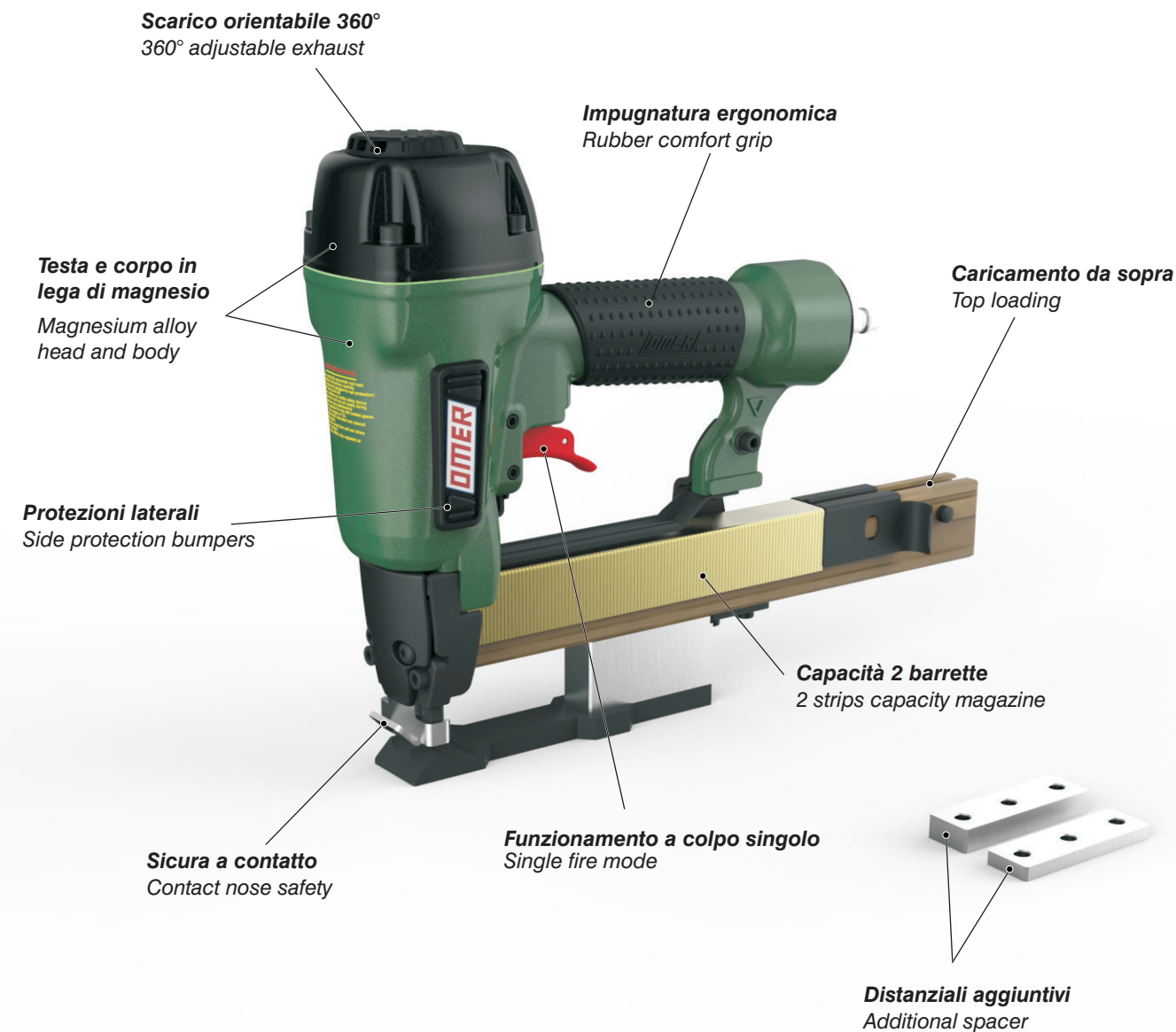

OMER

Manuale d'uso, manutenzione e parti di ricambio
Use, maintenance and spare parts manual
Gebrauchsanweisung, Instandhaltungsrichtlinien und Ersatzteile
Manuel d'utilisation, entretien et pièces de rechange
Manual de uso, mantenimiento y repuestos
 Εγχειρίδιο χρήσης, συντήρησης και ανταλλακτικών
Manual de utilização, manutenção e partes sobresselentes
Handleiding voor gebruik, onderhoud en reservedeelslijste
Brugsanvisning, vedligeholdelse og reservedeelsliste

Parte 2
Part 2
Teil 2
Partie 2
Part 2
 2° Μερους
Parte 2
Deel 2
Del 2



590.738 RF

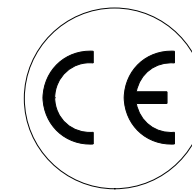

1748700RF_590738RF_4 290912 IV

cod. 1748700RF

Dati tecnici Technical data Technische daten	Données techniques Datos tècnicos Τεχνικά χαρακτηριστικά	Dados tècnicos Technischegegevens Teknische data
Misure impiegabili mm Usable lengths mm Gebrauchliche Längen mm	Mesures utilisables mm Medidas que se pueden emplear mm Διαστάσεις σε μμ	Medidas que se podem utilizar mm Te gebruiken lengtes in mm Brugbare laengder i mm
Capacità caricatore n° punti Magazine capacity No. of fasteners Magazinkapazität Nägel	Capacité chargeur n° de points Capacidad cargador n° puntos Δυνατότητα γεμιστέρα, σπινδύτερος	Capacidade carregador n° pontos Capaciteit magazijn in aantal spijkers Kapacitet af magasin antal klemme
Pressione d'esercizio Working pressure Betriebsdruck	Pression de fonctionnement Presión de trabajo Πίεση λειτουργίας ατμ.	Pressao de trabalho Werkdruk Arbejds tryk bar
Consumo aria litri/colpo Air consumption litres/shot Luftverbrauch Liter/Schlag	Consommation air litre/coup Consumo aire-litros/golpe Καταναλοση αερα λ/ξτωπημα	Consumo ar litro/golpe Luchtverbruik liter/schot Luftforbrug liter/skud
Peso kg Weight kg Gewicht kg	Poids kg Peso kg Βαρος κγ	Peso kg Gewicht in kg Vaegt kg
Dimensioni (AxBxH) mm Dimensions mm Größe mm	Dimension mm Dimensiones mm Δυνατότητα γεμιστέρα, σπινδύτερος	Dimencoes mm Afmetingen in mm Dimensioner mm
EN 12549 :1999 ISO 11201 :1995 Pressione sonora in pos. operatore Sound pressure at the workstation Lärmintensität am Arbeitsplatz	Pression acoustique près de l'opérateur Presión sonora en posición encargado Ακουστική πίεση στη θέση χειριστου	Intensidade sonora perto do operador Geluidsterkte op de werkplek Lydstyrke på operatorposten
EN 12549 :1999 ISO 3744 :1994 Potenza sonora emessa Emitted sound power Ausgestrahlte Lärmintensität	Puissance acoustique émise Potencia sonora emitida Ακουστική ισχυ	Potência sonora emitida Uitgestraalde geluidsterkte Udsendt lydstryke
EN 28662 :1992 ISO 5349 :1986 ISO 8662 -11 Valore medio ponderato di vibrazione sull'impugnatura Weighted mean value of vibration on the grip Mitteler Vibrationswert, am Griff Gemessen	Valeur moyenne pondérée de vibration mesurée sur la poignée Valor medio ponderado de vibracion medida en la empuñadura Μεσοσ ορος μετρησις κραδασιμων στη χειρολαβη	Valor medio ponderado de vibracao medida no punho Gewogen gemiddelde vibratiewaarde Middelvaerdi af vibrationer pa handtaget

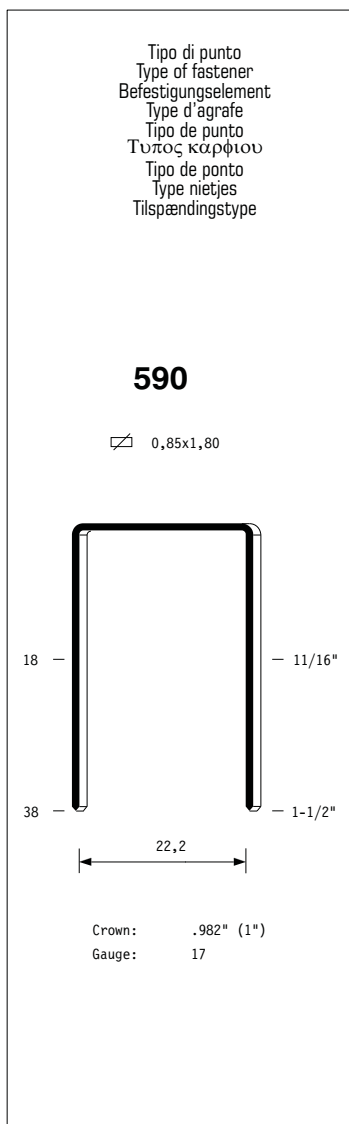

Parti di ricambio - Spare parts - Ersatzteile - Pièces de rechange - Piezas de repuesto
Ανταλλακτικά - Partes sobresselentes - Tabel te raadplegen - Reservedede

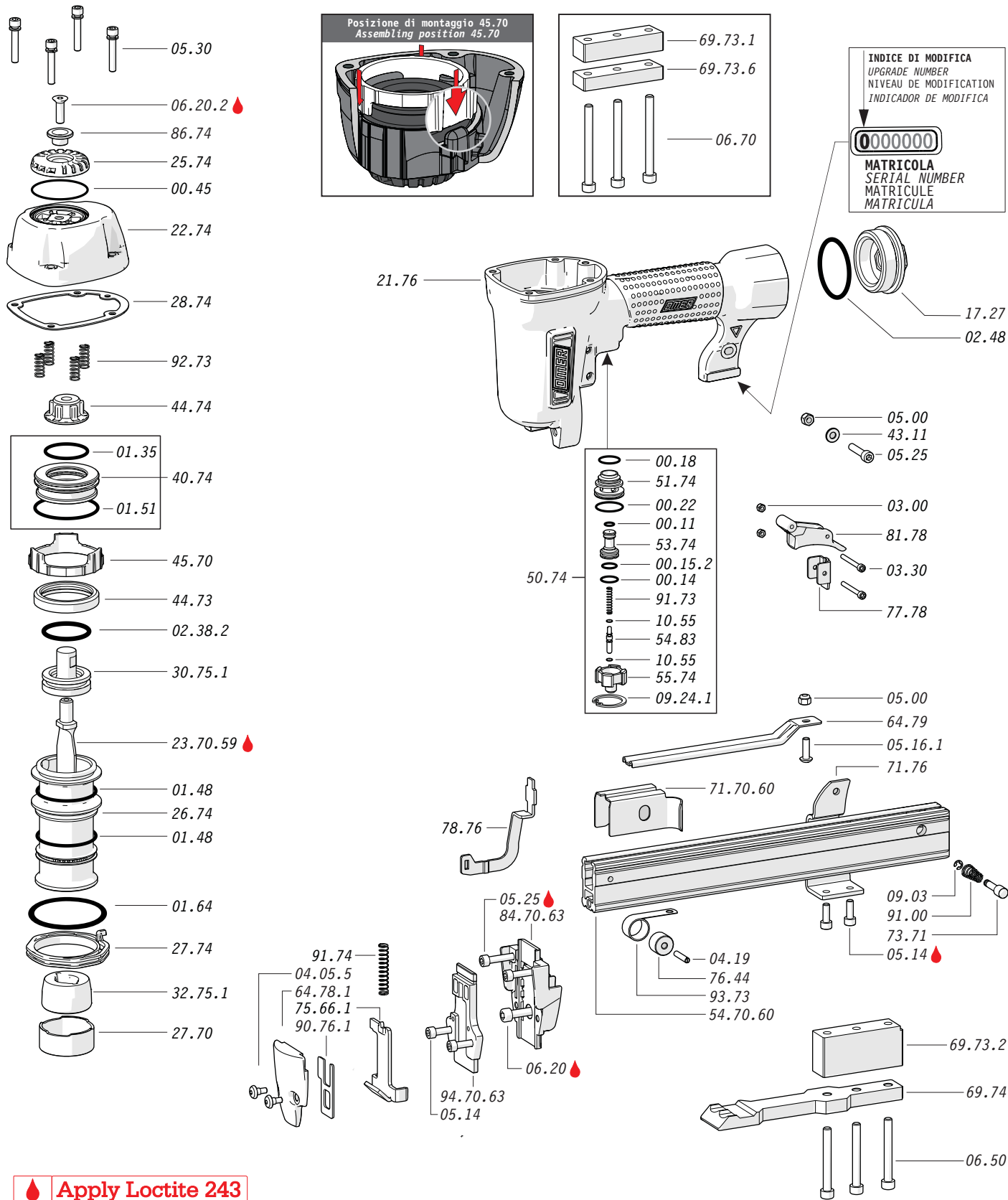

Apply Loctite 243

Dotazioni - Equipment - Ausrüstung - Équipements - Equipamiento - Παρεχόμενα
Equipamento - Uitrusting - Udstyr

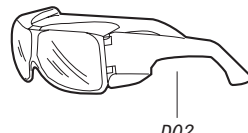
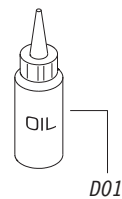
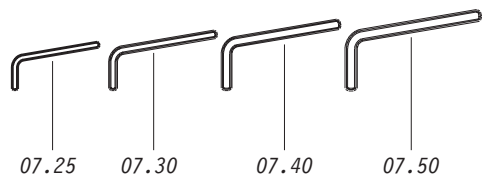

590.738 RF

cod. 1748700RF

Parti di ricambio - Spare parts - Ersatzteile - Pièces de rechange - Piezas de repuesto
Ανταλλακτικά - Partes sobresselentes - Tabel te raadplegen - Reservedede

Cod.	Descrizione	Description
00.11	O-Ring	O-Ring
00.14	O-Ring	O-Ring
00.15.2	O-Ring	O-Ring
00.18	O-Ring	O-Ring
00.22	O-Ring	O-Ring
00.45	O-Ring	O-Ring
01.35	O-Ring	O-Ring
01.48	O-Ring	O-Ring
01.51	O-Ring	O-Ring
01.64	O-Ring	O-Ring
02.38.2	O-Ring	O-Ring
02.48	O-Ring	O-Ring
03.00	Dado	Nut
03.30	Dado	Nut
04.05.5	Vite	Screw
04.19	Vite	Screw
05.00	Dado	Nut
05.14	Vite	Screw
05.16.1	Vite	Screw
05.25	Vite	Screw
05.30	Vite	Screw
06.20	Vite	Screw
06.20.2	Vite	Screw
06.70	Vite	Screw
06.50	Vite	Screw
07.25	Chiave esagonale	Hex. bar wrench
07.30	Chiave esagonale	Hex. bar wrench
07.40	Chiave esagonale	Hex. bar wrench
07.50	Chiave esagonale	Hex. bar wrench
09.03	Anello elastico	Elastic ring
09.24.1	Anello elastico	Elastic ring
10.55	O-Ring	O-Ring
17.27	Tappo	Inlet cap
21.76	Corpo	Body
22.74	Testa	Head
25.74	Deflettore scarico	Exhaust deflector
26.74	Cilindro	Cylinder
27.70	Anello	Ring
27.74	Anello cilindro	Cylinder ring
28.74	Guarnizione testa	Head gasket
30.75.1	Pistone	Piston
32.75.1	Ammortizzatore	Bumper
40.74	Valvola completa	Valve assembled
43.11	Rondella	Washer
44.73	Guarnizione cilindro	Cylinder gasket
44.74	Ammortizzatore sup.	Upper bumper
45.70	Distanziale	Spacer
50.74	Pulsante completo	Trigger valve assy
51.74	Boccola servovalvola	Servo valve bushing
53.74	Pistone servovalvola	Servo valve piston
54.83	Pulsante	Trigger valve
55.74	Raccordo pulsante	Trigger valve bush
64.78.1	Carter sicura	Safety guard
64.79	Carter	Hold down
69.73.1	Distanziale	Spacer
69.73.2	Distanziale	Spacer
69.73.6	Distanziale	Spacer
69.74	Ribattitore	Reverter
71.76	Reggicaricatore	Support
73.71	Perno	Pin
75.66.1	Sicura	Safety
76.44	Rullo molla	Roller
77.78	Guida sicura	Safety guide
78.76	Staffa sicura	Safety rod
81.78	Grilletto comando BF	BF Trigger
86.74	Boccola	Bushing
90.76.1	Piastra	Plate
91.00	Molla	Spring
91.73	Molla	Spring
91.74	Molla	Spring
92.73	Molla	Spring
93.73	Molla	Spring
23.70.59	Battente	Driver
52.70.60	Caricatore	Magazine
73.70.60	Spingipunto	Pusher
84.70.63	Controtestina	Nose
94.70.63	Testina	Nose plate
D01	Bocchetta olio	Oiler
D02	Occhiali protettivi	Protective goggles

Guarnizioni - O-Rings - Dichtungen - Kits - O-Rings - Ασπασμακία - Kit O-Rings - O-ringen - Pakninger

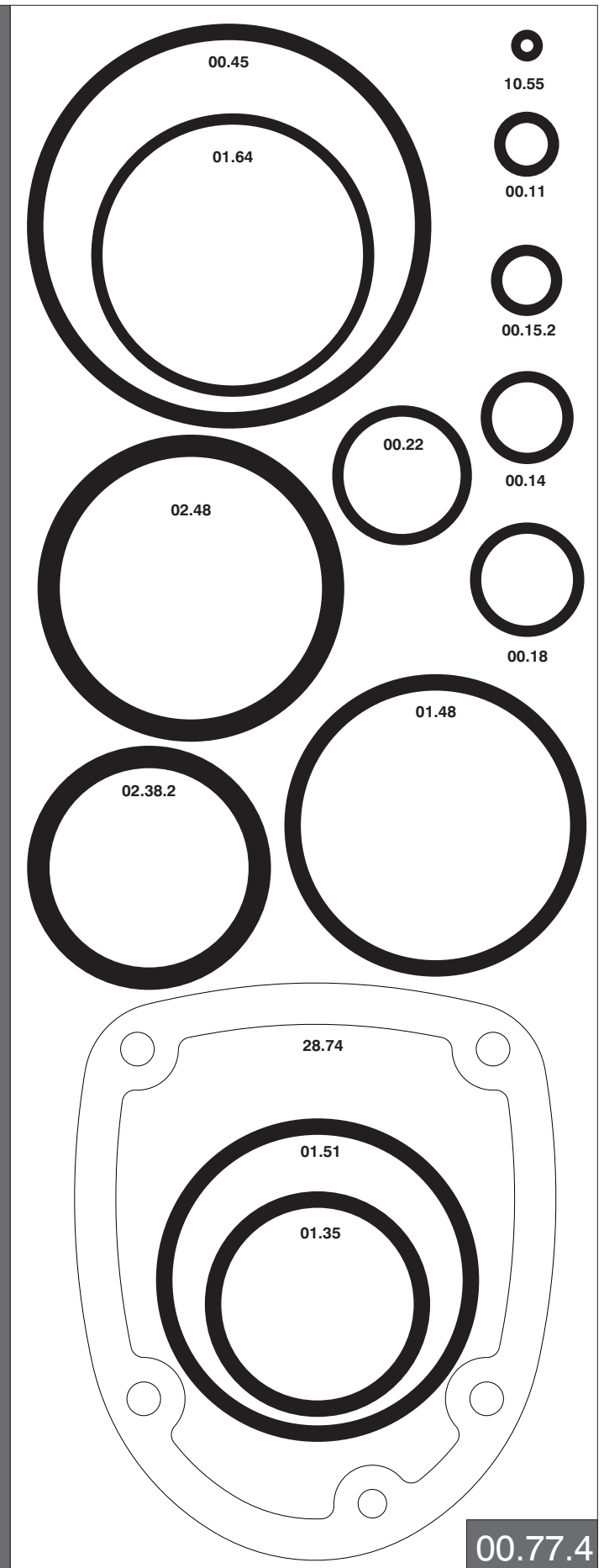

1748700RF_590738RF_4_290912_IV

590.738 RF

cod. 1748700RF

Indice di modifica
Upgrade number

4

4315919

Caricamento - Loading

- 1- Arretrare lo spingipunto e agganciarlo al fincorsa**
Pull the pusher backwards and lock it at the stop position at the end of the magazine

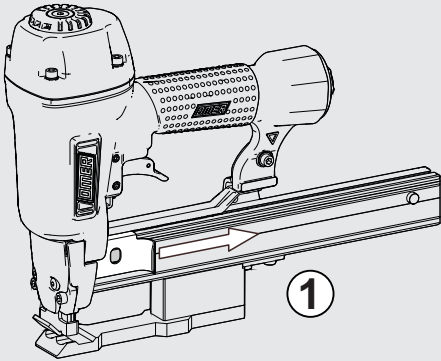

- 2- Inserire le graffe**
Load the magazine with staples

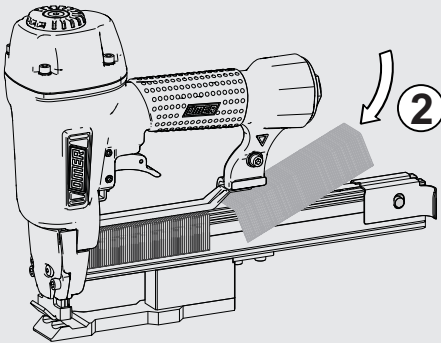

Non azionare MAI il grilletto comando o la sicura a contatto durante il caricamento.
NEVER actuate the trigger or the contact safety while loading.

- 3- Rilasciare lo spingipunto**
Release the pusher

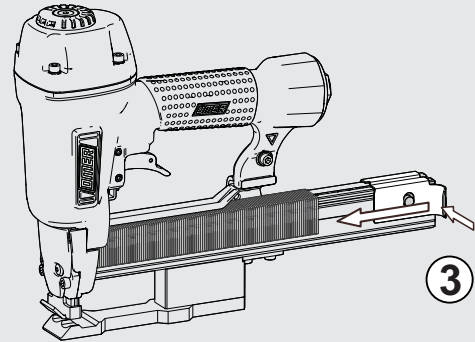

Funzionamento - Operating mode

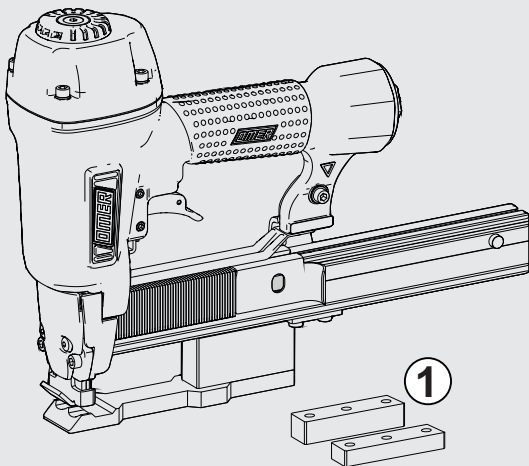

- 1- Consultare la tabella riepilogativa per scegliere la più opportuna combinazione di distanziali secondo lo spessore del materiale da fissare.**
Consultare la tabella riepilogativa per scegliere la più opportuna combinazione di distanziali secondo lo spessore del materiale da fissare.

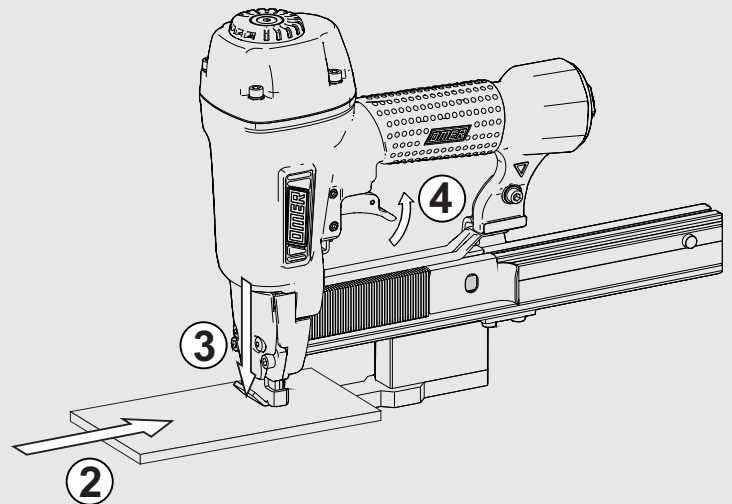

- 2- Inserire il materiale da fissare fra la testina e il ribattitore.**
Insert the material to be fastened between nose plate and reverter.
- 3- Premere la sicura sul materiale da fissare.**
Press the safety against the material to be fastened.
- 4- Premere il grilletto per sparare.**
Press the trigger to fire

Disinceppamento - Jam clearing



Scollegare la chiodatrice dall'impianto durante le operazioni di disinceppamento.
 Disconnect the tool from air supply while clearing a jam and maintenance.

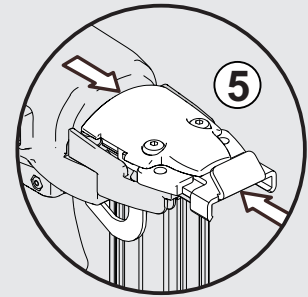
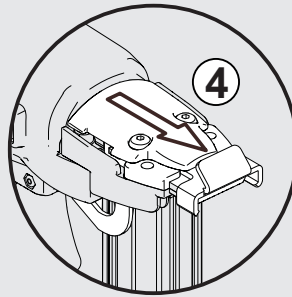
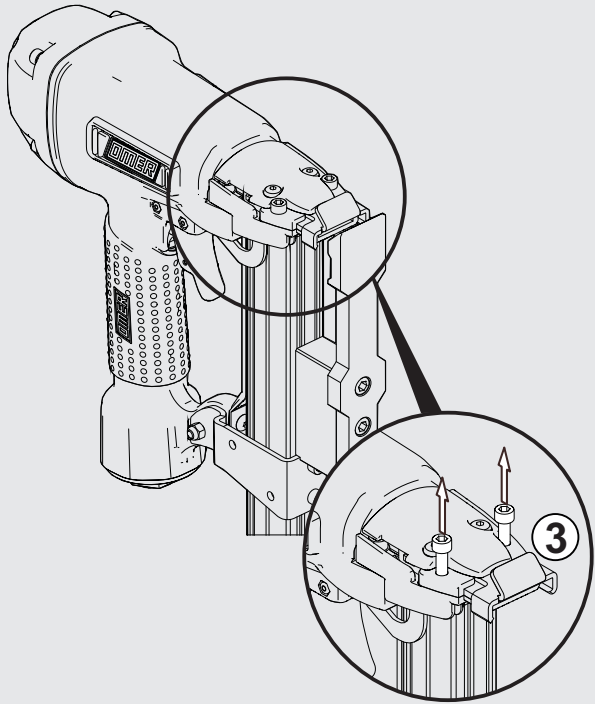
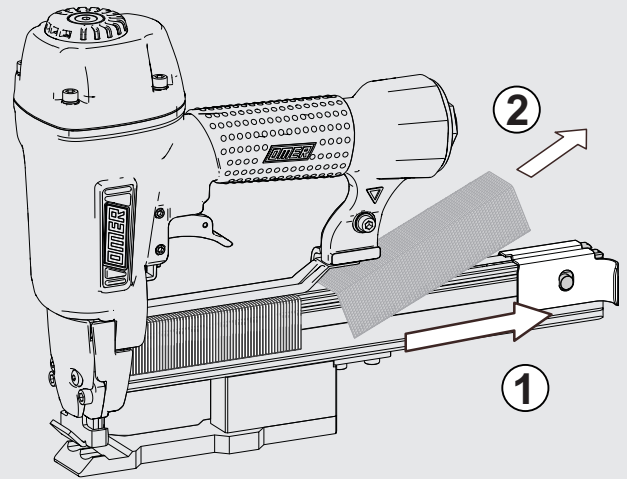

Mantenere premuto
 Keep pressed

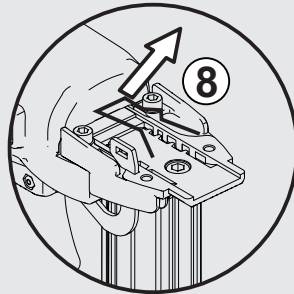
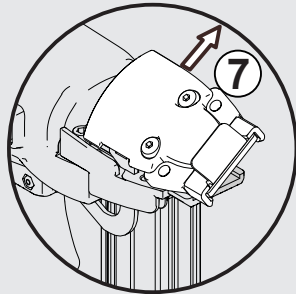
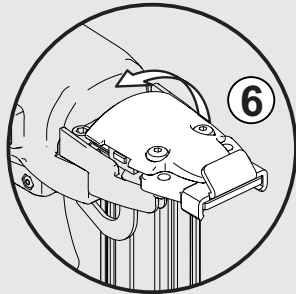

Riassemblare in ordine inverso

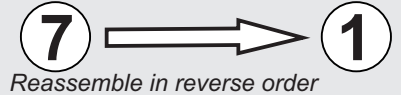

Reassemble in reverse order

Dati tecnici - Technical data

