



Manuale d'uso, manutenzione e parti di ricambio	Parte 2
Manual for use, maintenance and spare parts	Part 2
Bedienungs- und Wartungshandbuch sowie Ersatzteilleiste	Teil 2
Mode d'emploi, de maintenance et pièces de rechange	Partie 2
Manual de uso, mantenimiento y recambios	Part 2
Εγχειρίδιο χρήσης, συντήρησης και ανταλλακτικών	Μέρος 2
Manual de uso, manutenção e peças sobresselentes	Parte 2
Handleiding voor gebruik, onderhoud en wisselstukken	Deel 2
Kullanım, bakım ve yedek parça kılavuzu	Kısım 2



WK.738 CP

cod. 1749310CP

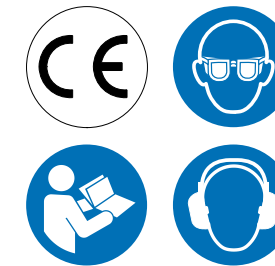
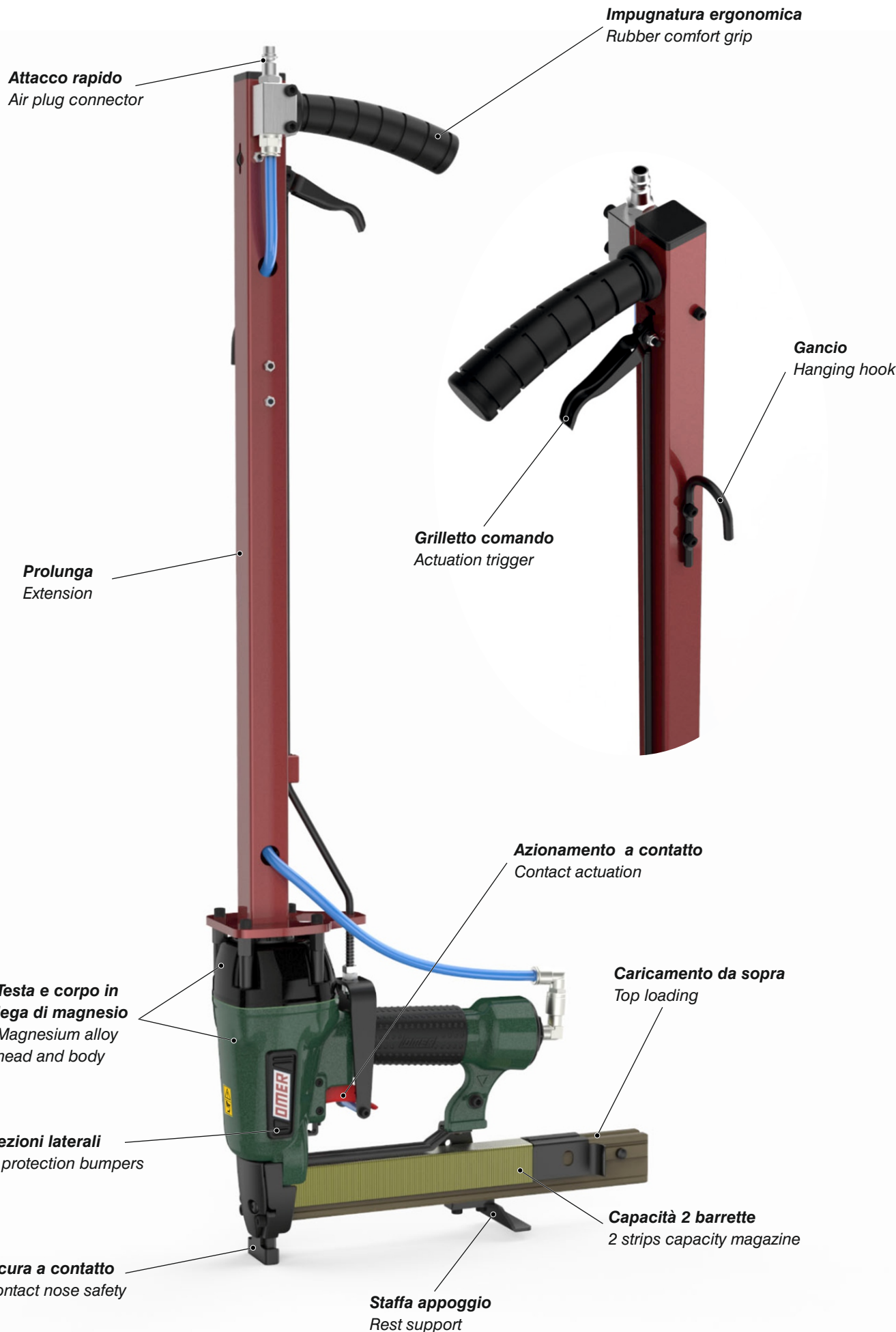

Warning: Please read the instructions and warnings for this tool carefully before use. Failure to do so could lead to serious injury.

Dati tecnici Technical data Technische Daten	Caractéristiques techniques Datos técnicos Τεχνικά χαρακτηριστικά	Dados técnicos Technische gegevens Teknik veriler	
Misure impiegabili mm Lengths mm Verwendbare Nagellänge mm	Dimensions utiles mm Medidas de longitud mm Μήκος Αναλωσίμου - mm	Medidas utilizáveis mm Toepasbare afmetingen mm Boy mm	15 ÷ 38
Capacità caricatore n° punti Magazine capacity Magazinkapazität Nägel	Capacité chargeur n° de points Capacidad cargador n° puntos Δωνατοτητα γεμιστερα	Capacidade carregador n° pontos Capaciteit magazijn in aantal spijkers Dergi kapasitesi	150
Pressione d'esercizio Operating pressure Betriebsdruck	Pression d'exercice Presión de servicio Πίεση λειτουργίας	Pressão de serviço Werkdruk Çalışma basıncı	5 ÷ 7,5 bar 70 ÷ 105 psi
Consumo aria litri/colpo Air consumption litres/stroke Luftverbrauch Liter/Schuss	Consommation d'air litres/coup Consumo aire litros/golpe Κατανάλωση αέρα - λίτρα/βολή	Consumo ar litros/disparo Luchtverbruik liter/slag Litre/vuruş hava tüketimi	0,75
Peso kg Weight kg Gewicht kg	Poids kg Peso kg Βάρος - kg	Peso kg Gewicht in kg Ağırlık kg	4,06
Dimensioni mm Dimensions mm Abmessungen mm	Dimensions mm Dimensiones mm Διαστάσεις mm	Dimensões mm Afmetingen mm Boyutlar mm	345x104x870 (LxWxH)
UNI EN 12549 :2009 UNI EN ISO 4871 :2009	Pressione sonora in pos. operatore Sound pressure in operator's position Schalldruck am Arbeitsplatz	Pressão sonora na posição Operador Geluidsdruk op de werkplaats Operatör pozisyonunda ses basıncı	90 dB(A) (K= 4 dB)
UNI EN 12549 :2009 UNI EN ISO 3746 :2011 UNI EN ISO 4871 :2009	Potenza sonora emessa Sound power emitted Emitierte Schalleistung	Potência sonora emitida Geëmitteerd geluidsvermogen Çıkan ses gücü (ses desibel)	98 dB(A) (K= 4 dB)
UNI CEN ISO/TS 8662-11 :2006 UNI EN ISO 5349-2 :2004 UNI EN 12096 :1999	Emissione vibratoria sull'impugnatura Vibratory emissions on handle Vibrationsemission am Griff	Emission vibratoire sur la prise en main Emisión de vibraciones en la empuñadura Tutamak üzerinde vibrasyon emisyonları	5,71 m/s² (K= 2 m/s ²)

Tipo di punto
Type of fastener
Befestigungsmittel
Type de rivet
Τύπος αναλωσίμου
Tipo de agrafo
Type nietjes
Zimba ve çivi tipleri

WK

1,40x1,60

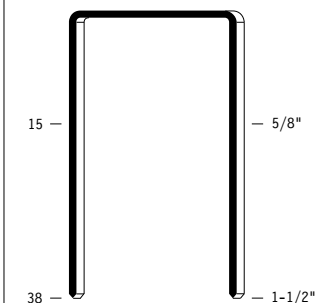

20,4

Crown: .913" (15/16")
Gauge: 16

Parti di ricambio - Spare parts - Ersatzteile - Pièces de rechange - Recambios
Ανταλλακτικά - Partes sobresselentes - Wisselstukken - Yedek parçalar

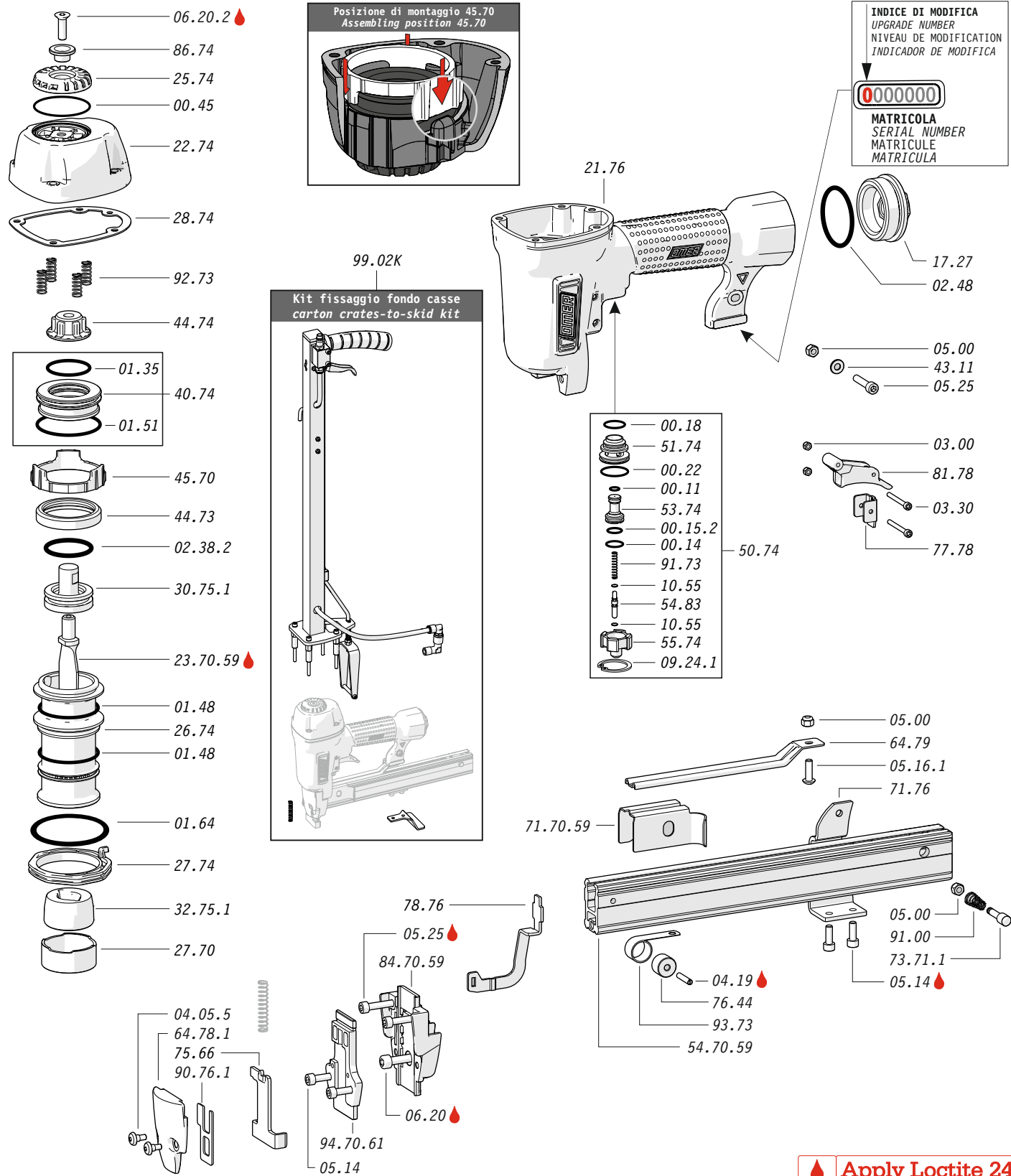

Dotazioni - Equipment - Ausstattung - Outillage - Dotaciones - Εξοπλισμός
Dotações - Uitrusting - Donanımlar

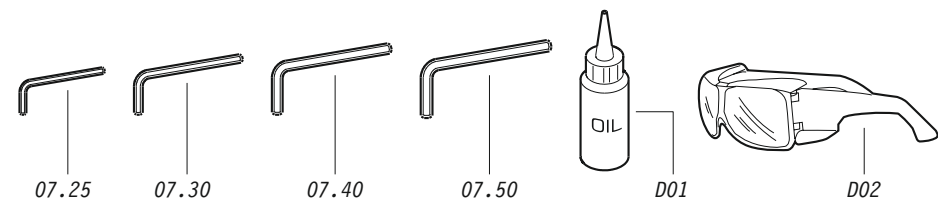

WK.738 CP

cod. 1749310CP

Disinceppamento - Jam clearing - Staubeseitigung - Décoincement - Desatascamiento - Απεμπλοκή
Desencravamento - Deblokkering bij vastlopen - Sıkışma giderme

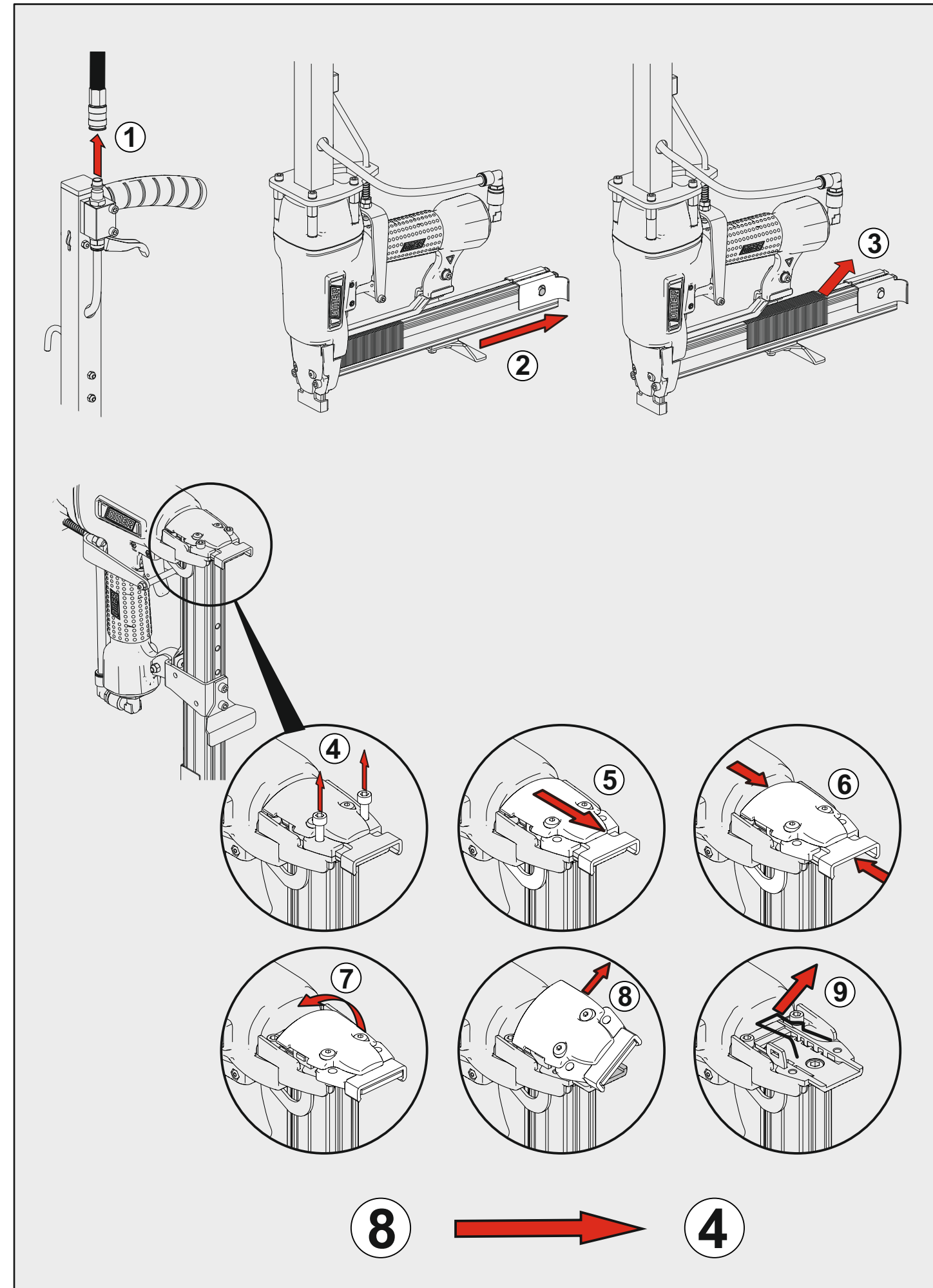

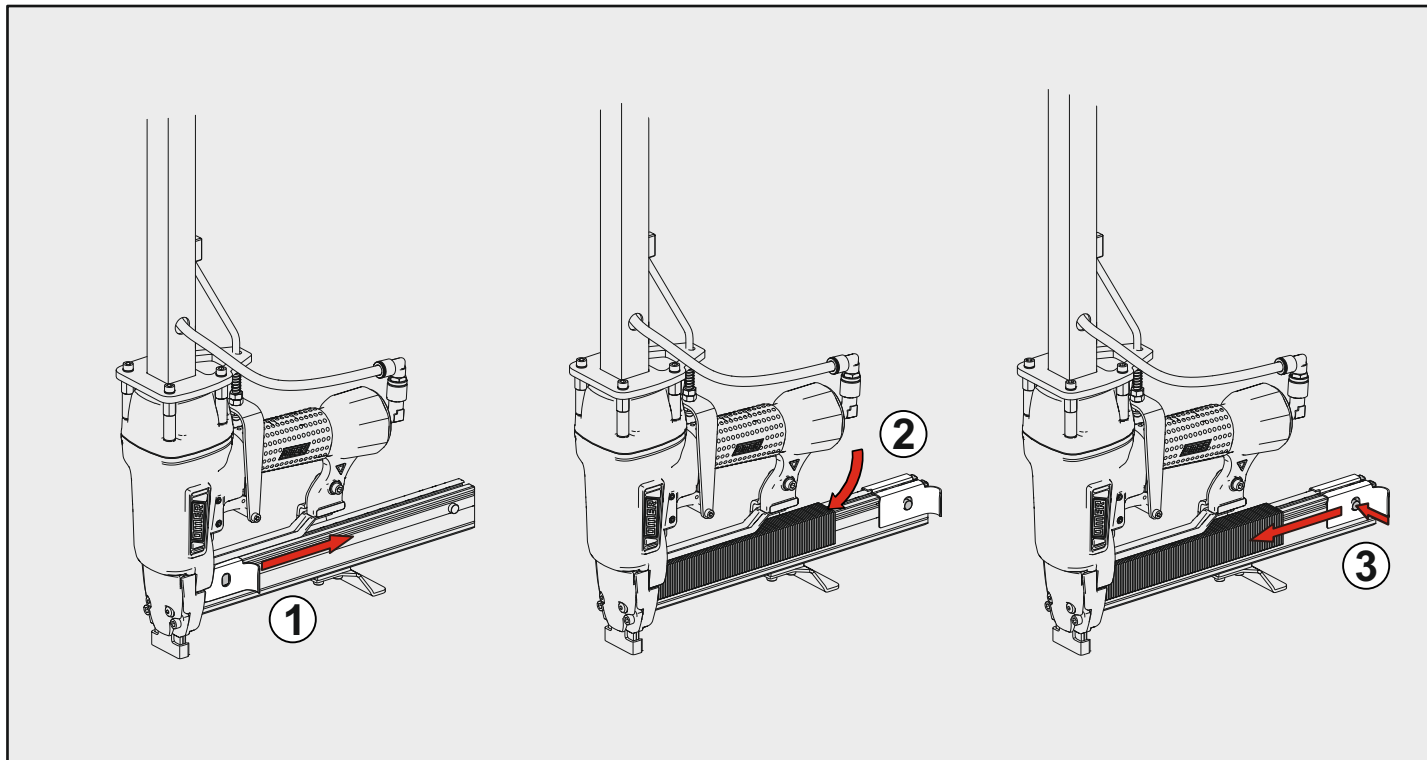

Azionamento a contatto
Contact actuation

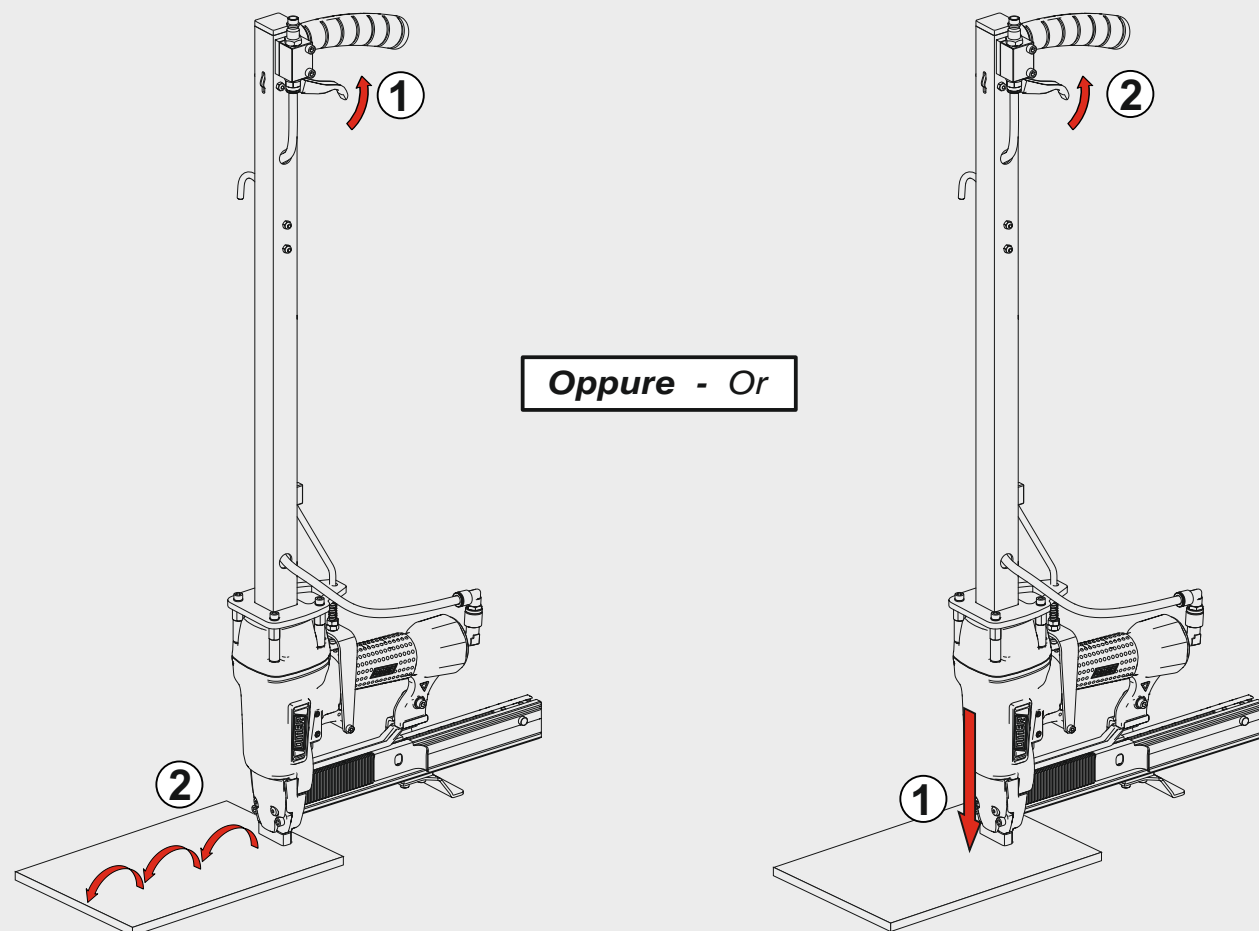

Cod.	Descrizione	Description
00.11	O-Ring	O-Ring
00.14	O-Ring	O-Ring
00.15.2	O-Ring	O-Ring
00.18	O-Ring	O-Ring
00.22	O-Ring	O-Ring
00.45	O-Ring	O-Ring
01.35	O-Ring	O-Ring
01.48	O-Ring	O-Ring
01.51	O-Ring	O-Ring
01.64	O-Ring	O-Ring
02.38.2	O-Ring	O-Ring
02.48	O-Ring	O-Ring
03.00	Dado	Nut
03.30	Vite	Screw
04.05.5	Vite	Screw
04.19	Vite	Screw
05.00	Dado	Nut
05.14	Vite	Screw
05.16.1	Vite	Screw
05.25	Vite	Screw
06.20	Vite	Screw
06.20.2	Vite	Screw
07.25	Chiave esagonale	Hex. bar wrench
07.30	Chiave esagonale	Hex. bar wrench
07.40	Chiave esagonale	Hex. bar wrench
07.50	Chiave esagonale	Hex. bar wrench
09.24.1	Anello elastico	Elastic ring
10.55	O-Ring	O-Ring
17.27	Tappo	Inlet cap
21.76	Corpo	Body
22.74	Testa	Head
25.74	Deflettore scarico	Exhaust deflector
26.74	Cilindro	Cylinder
27.70	Anello	Ring
27.74	Anello cilindro	Cylinder ring
28.74	Guarnizione testa	Head gasket
30.75.1	Pistone	Piston
32.75.1	Ammortizzatore	Bumper
40.74	Valvola completa	Valve assembled
43.11	Rondella	Washer
44.73	Guarnizione cilindro	Cylinder gasket
44.74	Ammortizzatore sup.	Upper bumper
45.70	Distanziale	Spacer
50.74	Pulsante completo	Trigger valve assy
51.74	Boccola servovalvola	Servo valve bushing
53.74	Pistone servovalvola	Servo valve piston
54.83	Pulsante	Trigger valve
55.74	Raccordo pulsante	Trigger valve bush
64.78.1	Carter sicura	Safety guard
64.79	Carter	Hold down
71.76	Reggicaricatore	Support
73.71.1	Perno	Pin
75.66	Sicura	Safety
76.44	Rullo molla	Roller
77.78	Guida sicura	Safety guide
78.76	Rinvio sicura	Safety rod
81.78	Grilletto comando BF	BF Trigger
86.74	Boccola	Bushing
90.76.1	Piastra	Plate
91.00	Molla	Spring
91.73	Molla	Spring
92.73	Molla	Spring
93.73	Molla	Spring
99.02K	Kit fissaggio fondi casse	Crates-to-skid Kit
23.70.59	Battente	Driver
54.70.59	Caricatore	Magazine
71.70.59	Spingipunto	Pusher
84.70.59	Controtestina	Nose
94.70.61	Testina	Nose plate
D01	Bocchetta olio	Oiler
D02	Occhiali protettivi	Protective goggles

Guarnizioni - O-Rings - Dichtungen - Joints toriques - Δακτύλιος στεγανοποίησης - Vedantes - O-ringen - Contalar

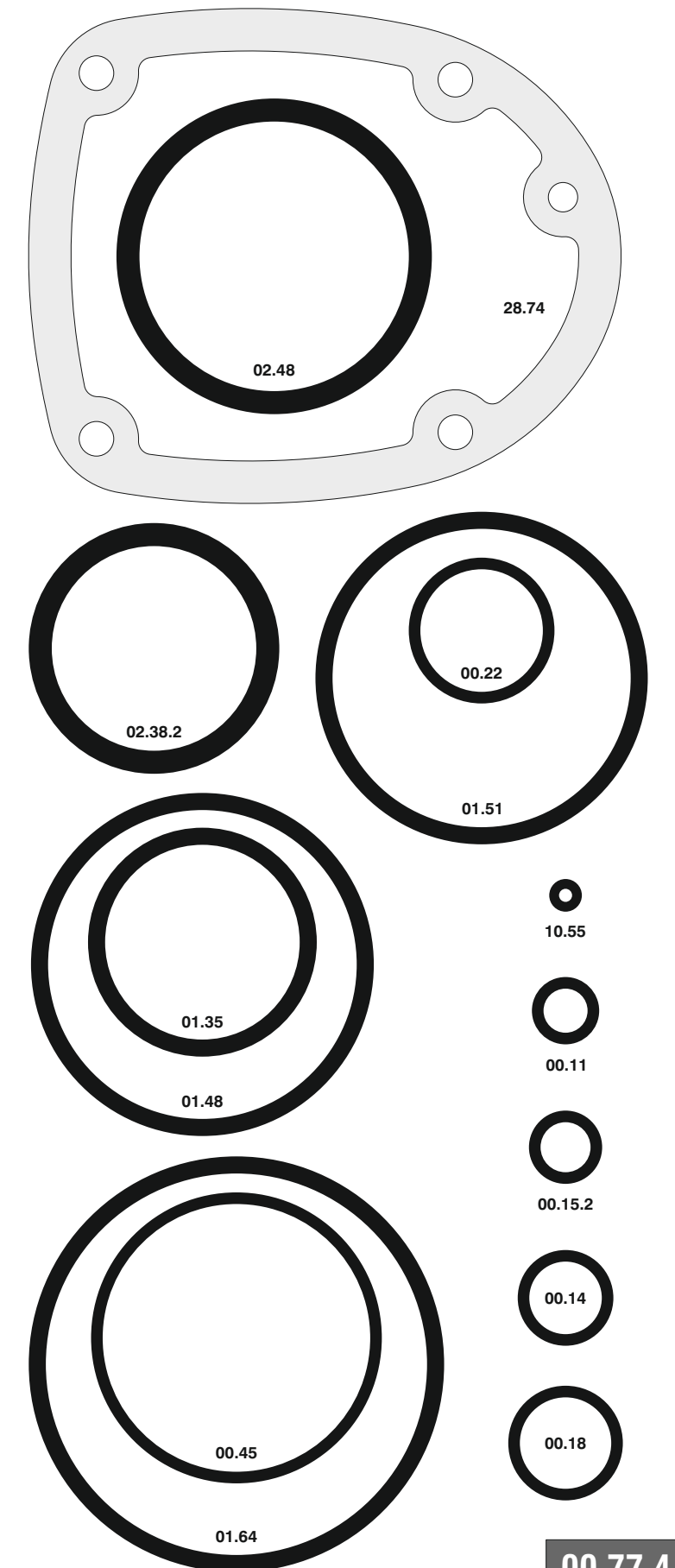

Parti di ricambio - Spare parts - Ersatzteile - Pièces de rechange - Recambios
Ανταλλακτικά - Partes sobresselentes - Wisselstukken - Yedek parçalar

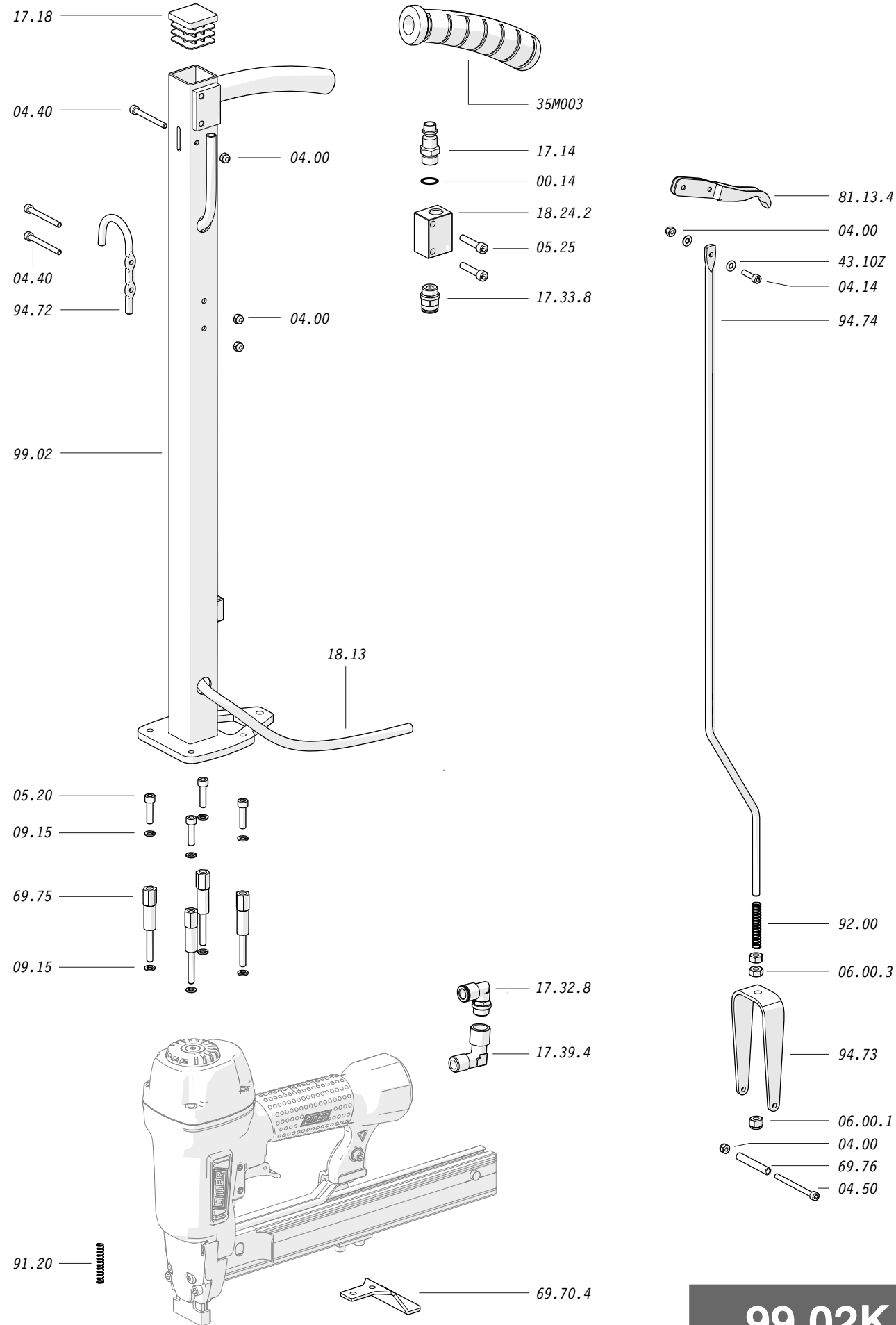

99.02K

Parti di ricambio - Spare parts - Ersatzteile - Pièces de rechange - Recambios
Ανταλλακτικά - Partes sobresselentes - Wisselstukken - Yedek parçalar

Cod.	Descrizione	Description
00.14	O-Ring	O-Ring
04.00	Dado	Nut
04.14	Vite	Screw
04.40	Vite	Screw
04.50	Vite	Screw
05.00	Dado	Nut
05.14	Vite	Screw
05.20	Vite	Screw
05.25	Vite	Screw
06.00.1	Dado	Nut
06.00.3	Dado	Nut
09.15	Rondella	Washer
17.14	Attacco rapido	Air plug
17.18	Tappo	Inlet cap
17.32.8	Raccordo "L"	Connection "Elbow"
17.33.8	Raccordo "D"	Connection "Straight"
17.39.4	Raccordo "L"	Connection "Elbow"
18.24.2	Distributore	Distributor
18.13	Tubo	Tube
43.10Z	Rondella	Washer
69.70.4	Staffa appoggio	Rest support
69.75	Vite-distanziale	Spacer-screw
69.76	Distanziale	Spacer
81.13.4	Grilletto	Trigger
91.20	Molla	Spring
92.00	Molla	Spring
94.72	Gancio	Hook
94.72.1	Gancio	Hook
94.72.1K	Supporto bilanciante	Tool hanger
94.73	Forcella	Fork
94.74	Tirante	Rod
99.02	Prolunga	Extension
35M003	Impugnatura gomma	Rubber grip

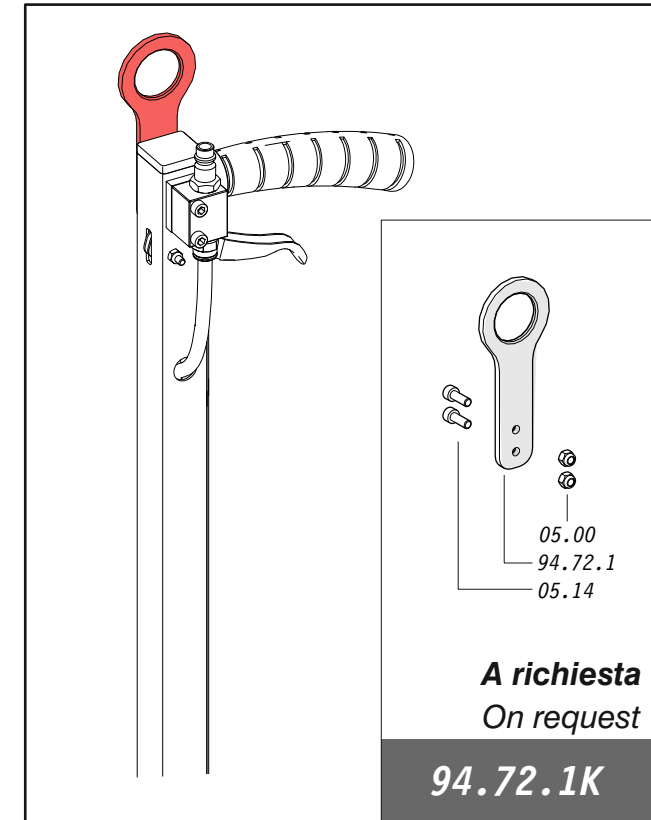

A richiesta
On request

94.72.1K

Dati tecnici - Technical data - Technische Daten - Caractéristiques techniques - Datos técnicos
Τεχνικά χαρακτηριστικά - Dados técnicos - Technische gegevens - Teknik veriler

