

## Schema di collegamento - Connecting diagram

**Collegamento per valvola 3/2 NC**  
Connection for valve 3/2 NC

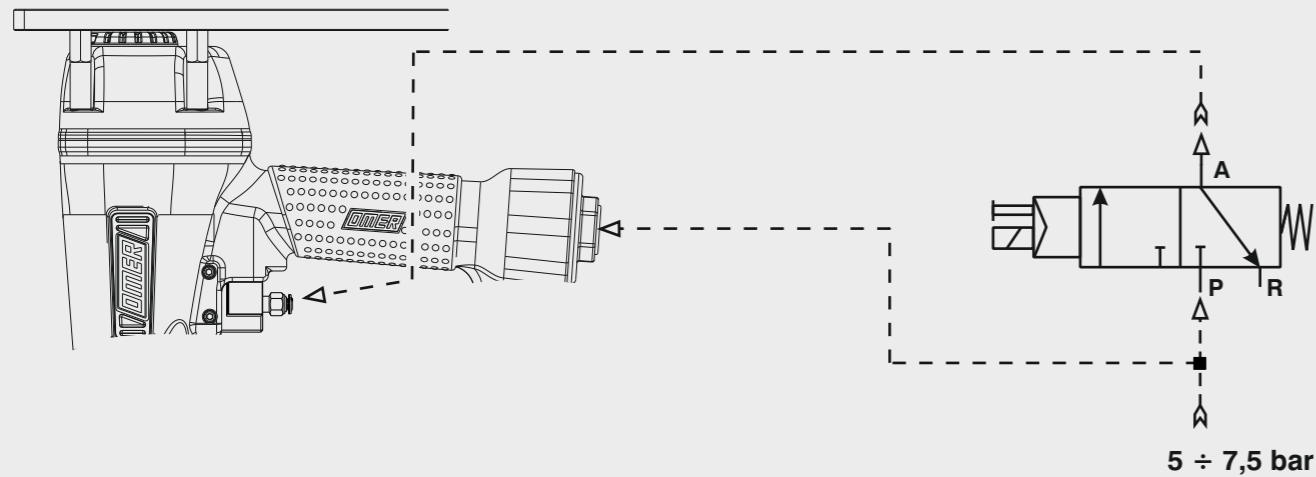

**Dotazioni - Equipment - Ausstattung - Outillage - Dotaciones - Εξοπλισμός**  
Dotações - Uitrusting - Donanımlar

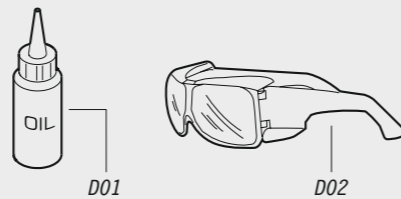
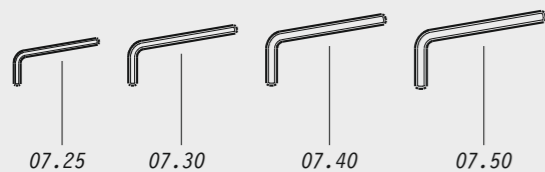

**Caratteristiche - Features - Merkmale - Caractéristiques - Características - Χαρακτηριστικά - Características - Kenmerken - Özellikler**

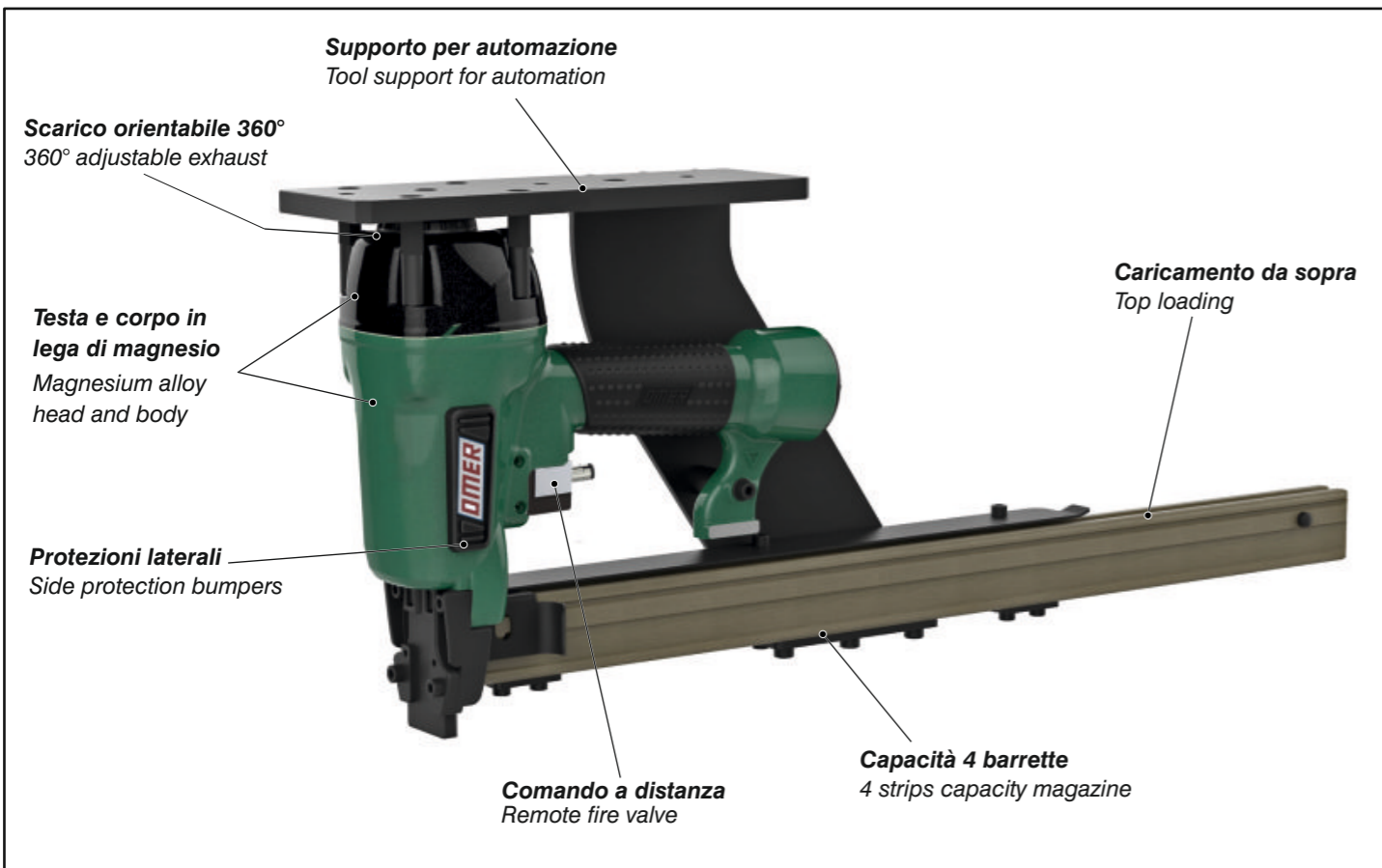

**Manuale d'uso, manutenzione e parti di ricambio**  
Manual for use, maintenance and spare parts  
Bedienungs- und Wartungshandbuch sowie Ersatzteilleiste  
Mode d'emploi, de maintenance et pièces de rechange  
Manual de uso, mantenimiento y recambios  
Εγχειρίδιο χρήσης, συντήρησης και ανταλλακτικών  
Manual de uso, manutenção e peças sobresselentes  
Handleiding voor gebruik, onderhoud en wisselstukken  
Kullanım, bakım ve yedek parça kılavuzu

**Parte 2**  
Part 2  
Teil 2  
Partie 2  
Part 2  
Μέρος 2  
Parte 2  
Deel 2  
Kısım 2

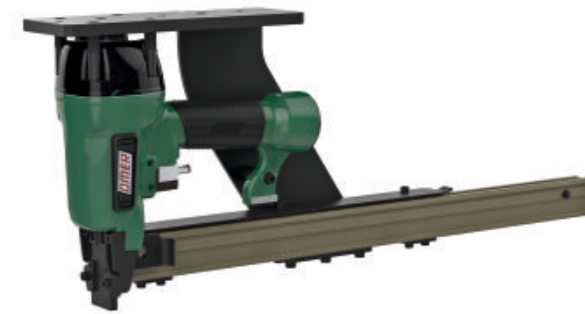

**WK.738 CL4-4**

cod. 17493540-4

<b>Dati tecnici</b> Technical data Technische Daten	<b>Caractéristiques techniques</b> Datos técnicos Τεχνικά χαρακτηριστικά	<b>Dados técnicos</b> Technische gegevens Teknik veriler
---	--	--

<b>Misure impiegabili mm</b> Lengths mm Verwendbare Nagellänge mm	Dimensions utiles mm Medidas de longitud mm Μήκος Αναλωσίμου - mm	Medidas utilizáveis mm Toepasbare afmetingen mm Boy mm	<b>15 ÷ 38</b>
<b>Capacità caricatore n° punti</b> Magazine capacity Magazinkapazität Nägel	Capacité chargeur n° de points Capacidad cargador n° puntos Δωνατοτητα γεμιστερα	Capacidade carregador n° pontos Capaciteit magazijn in aantal spijkers Dergi kapasitesi	<b>300</b>
<b>Pressione d'esercizio</b> Operating pressure Betriebsdruck	Pression d'exercice Presión de servicio Πίεση λειτουργίας	Pressão de serviço Werkdruk Çalışma basıncı	<b>5 ÷ 7,5 bar</b> <b>70 ÷ 105 psi</b>
<b>Consumo aria litri/colpo</b> Air consumption litres/stroke Luftverbrauch Liter/Schuss	Consumption d'air litres/coup Consumo aire litros/golpe Κατανάλωση αέρα - λίτρα/βολή	Consumo ar litros/disparo Luchtverbruik liter/slag Litre/vuruş hava tüketimi	<b>0,75</b>
<b>Peso kg</b> Weight kg Gewicht kg	Poids kg Peso kg Βάρος - kg	Peso kg Gewicht in kg Ağırlık kg	<b>4,70</b>
<b>Dimensioni mm</b> Dimensions mm Abmessungen mm	Dimensions mm Dimensiones mm Διαστάσεις mm	Dimensões mm Afmetingen mm Boyutlar mm	<b>621x80x247</b> (LxWxH)
<b>UNI EN 12549 :2009</b>	<b>UNI EN ISO 3746 :2011</b>	<b>UNI EN ISO 4871 :2009</b>	
<b>Potenza sonora emessa</b> Sound power emitted Emittierte Schallleistung	Puissance sonore émise Potencia sonora emitida Εκπεμπόμενη ηχητική ισχύς	Potência sonora emitida Geëmitteerd geluidsvermogen Çıkan ses gücü (ses desibeli)	<b>98 dB(A)</b> (K = 4 dB)

**Tipo di punto**  
Type of fastener  
Befestigungsmittel  
Type de rivet  
Tipo de punto  
Τύπος αναλωσίμου  
Tipo de agrafa  
Type nietjes  
Zimba ve çivi tipleri

**WK**

1,40x1,60

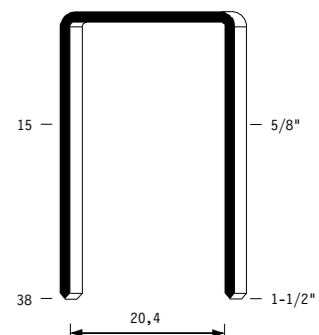

Gauge: 16  
Crown: .913" (15/16")

17493540-4\_WK738CL4-4\_rev20\_07/09/2022 DV

**DO NOT  
HANDHELD  
THIS TOOL**



Parti di ricambio - Spare parts - Ersatzteile - Pièces de rechange - Recambios  
Ανταλλακτικά - Partes sobresselentes - Wisselstukken - Yedek parçalar

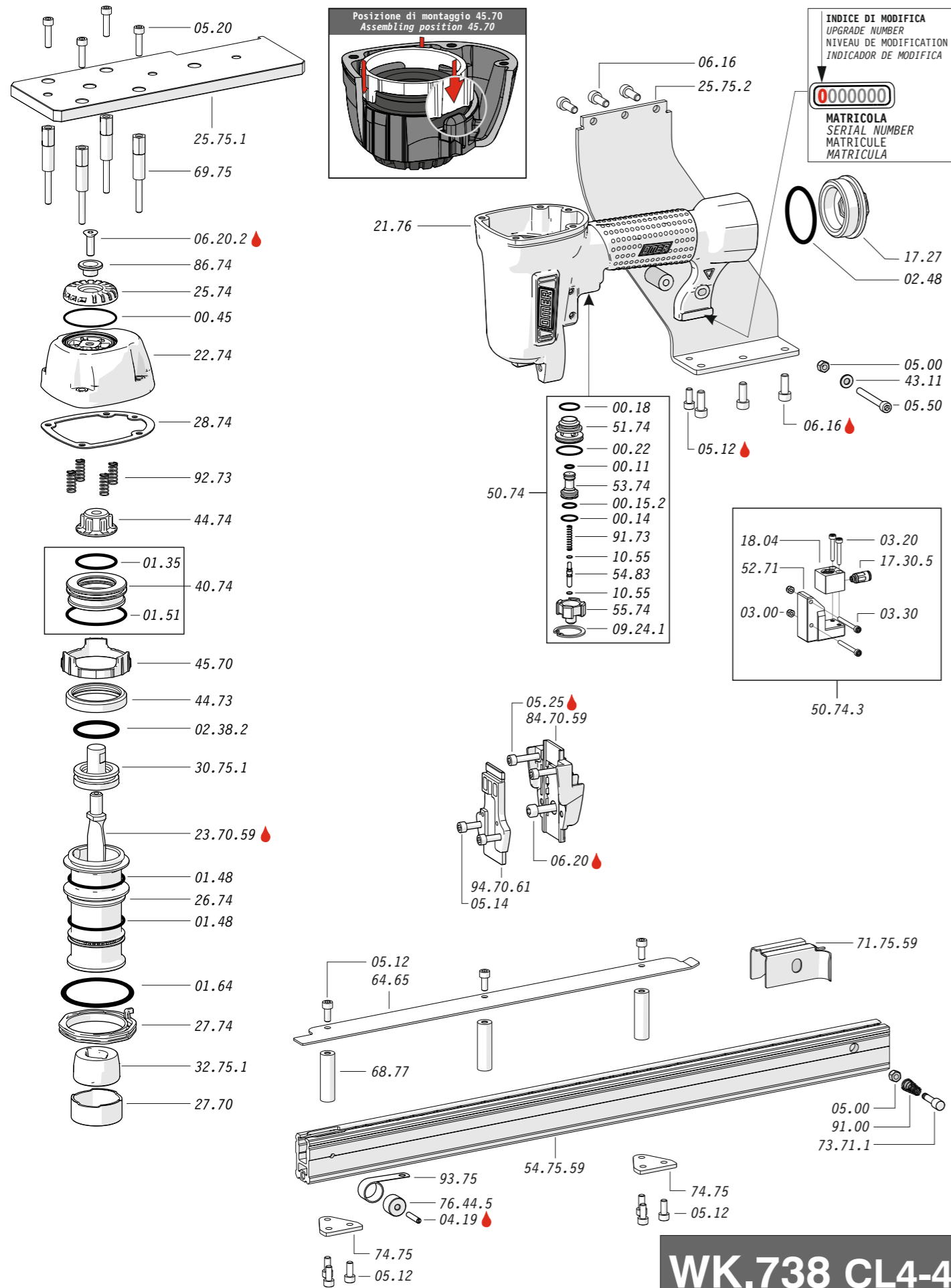

**WK.738 CL4-4**

cod. 17493540-4

Apply Loctite 243

Parti di ricambio - Spare parts - Ersatzteile - Pièces de rechange - Recambios  
Ανταλλακτικά - Partes sobresselentes - Wisselstukken - Yedek parçalar

Cod.	Descrizione	Description
00.11	O-Ring	O-Ring
00.14	O-Ring	O-Ring
00.15.2	O-Ring	O-Ring
00.18	O-Ring	O-Ring
00.22	O-Ring	O-Ring
00.45	O-Ring	O-Ring
01.35	O-Ring	O-Ring
01.48	O-Ring	O-Ring
01.51	O-Ring	O-Ring
01.64	O-Ring	O-Ring
02.38.2	O-Ring	O-Ring
02.48	O-Ring	O-Ring
03.00	Dado	Nut
03.20	Vite	Screw
03.30	Vite	Screw
04.19	Vite	Screw
05.00	Dado	Nut
05.12	Vite	Screw
05.14	Vite	Screw
05.20	Vite	Screw
05.25	Vite	Screw
05.50	Vite	Screw
06.16	Vite	Screw
06.20	Vite	Screw
06.20.2	Vite	Screw
07.25	Chiave esagonale	Hex. bar wrench
07.30	Chiave esagonale	Hex. bar wrench
07.40	Chiave esagonale	Hex. bar wrench
07.50	Chiave esagonale	Hex. bar wrench
09.24.1	Anello elastico	Elastic ring
10.55	O-Ring	O-Ring
17.27	Tappo	Inlet cap
17.30.5	Raccordo	Air plug
18.04	Cilindro	Cylinder
21.76	Corpo	Body
22.74	Testa	Head
25.74	Deflettore scarico	Exhaust deflector
25.75.1	Piastra superiore	Upper plate
25.75.2	Supporto	Support
26.74	Cilindro	Cylinder
27.70	Anello	Ring
27.74	Anello cilindro	Cylinder ring
28.74	Guarnizione testa	Head gasket
30.75.1	Pistone	Piston
32.75.1	Ammortizzatore	Bumper
40.74	Valvola completa	Valve assembled
43.11	Rondella	Washer
44.73	Guarnizione cilindro	Cylinder gasket
44.74	Ammortizzatore sup.	Upper bumper
45.70	Distanziale	Spacer
50.74	Pulsante completo	Complete button
50.74.3	Comando a distanza	Remote fire
51.74	Boccola servovalvola	Servo valve bushing
52.71	Supporto	Support
53.74	Pistone servovalvola	Servo valve piston
54.83	Pulsante	Button
55.74	Raccordo pulsante	Trigger valve bush
64.65	Carter	Hold down
68.77	Distanziale	Spacer
69.75	Distanziale	Spacer
73.71.1	Perno	Pin
74.75	Staffa	Plate
76.44.5	Rullo molla	Roller
86.74	Boccola	Bushing
91.00	Molla	Spring
91.73	Molla	Spring
92.73	Molla	Spring
93.75	Molla	Spring
23.70.59	Battente	Driver
54.75.59	Caricatore	Magazine
71.75.59	Spingipunto	Pusher
84.70.59	Controtestina	Nose
94.70.61	Testina	Nose plate
D01	Bocchetta olio	Oiler
D02	Occhiali protettivi	Protective goggles

**WK.738 CL4-4**

cod. 17493540-4

Guarnizioni - O-Rings - Dichtungen - Joints toriques - Juntas - Δακτύλιος στεγανοποίησης - Vedantes - O-ringen - Contalar

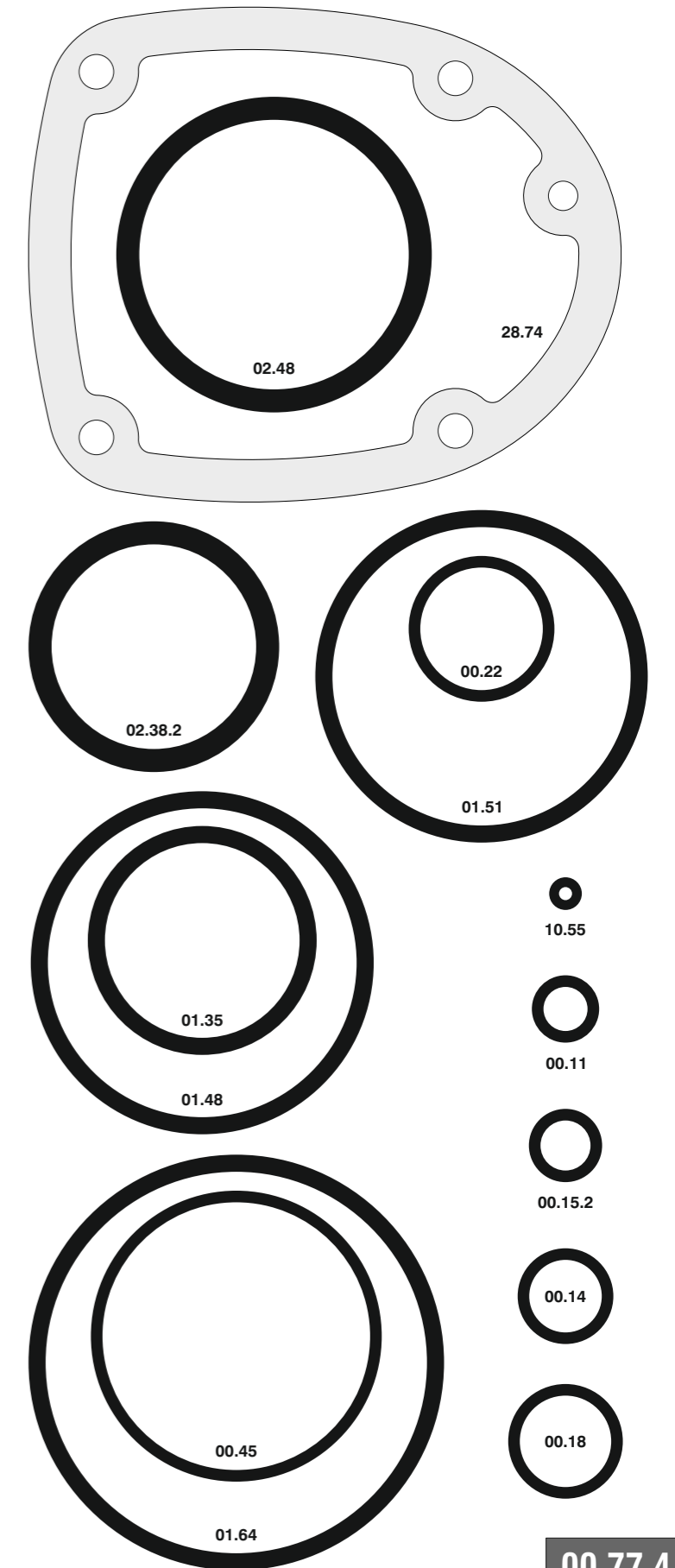

00.77.4

Indice di modifica  
Upgrade number

4

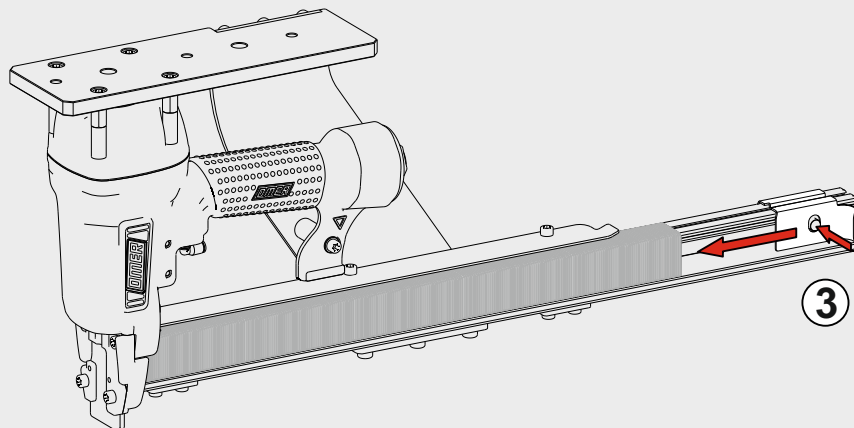
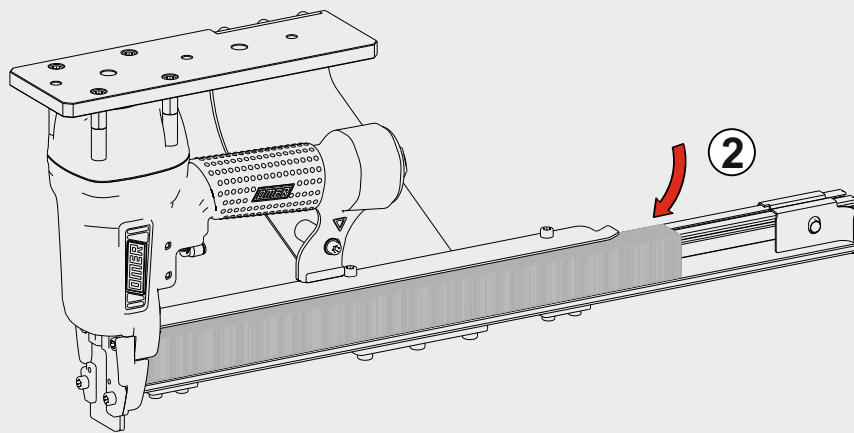
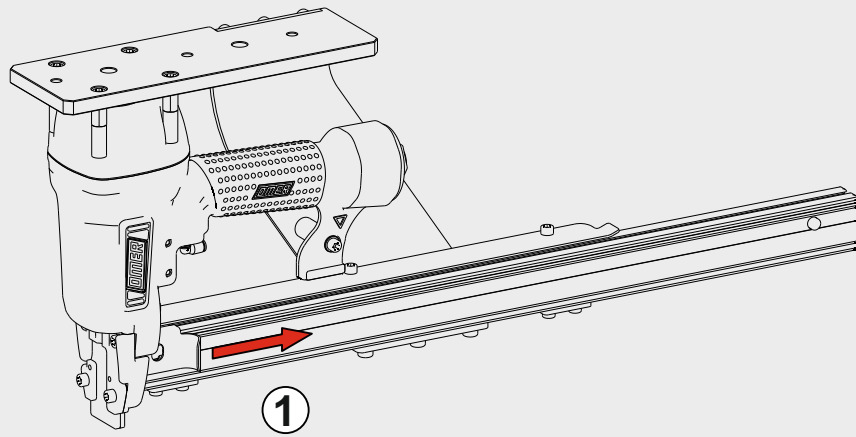

Disinceppamento - Jam clearing - Staubeseitigung - Décoincement - Desatascamiento - Απεμπλοκή  
Desencravamento - Deblokkering bij vastlopen - Sikişma giderme

