

## Modalità sparo - Fire mode selection

### Colpo martello Bump fire

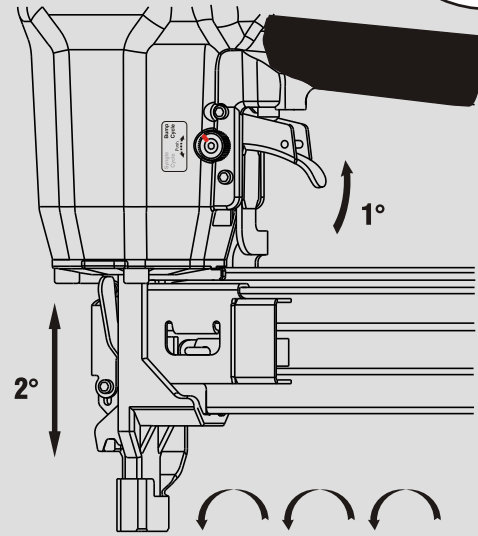

### Colpo singolo Sequential fire

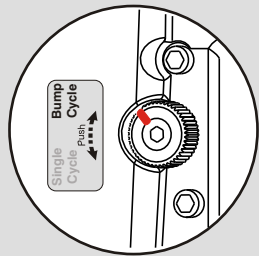
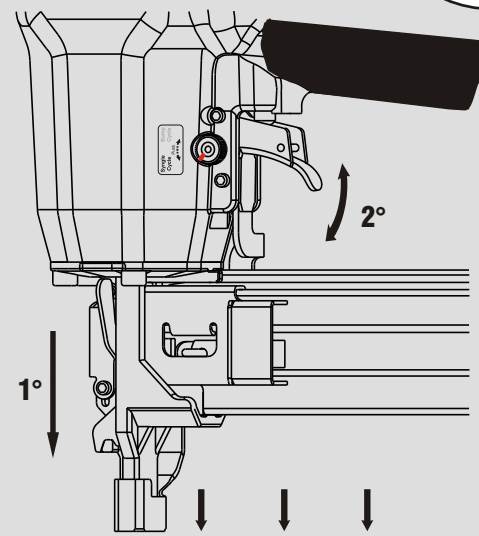
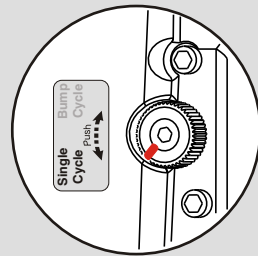

## Caratteristiche - Features

### Disinceppamento rapido macchina Quick clearance jammed nails

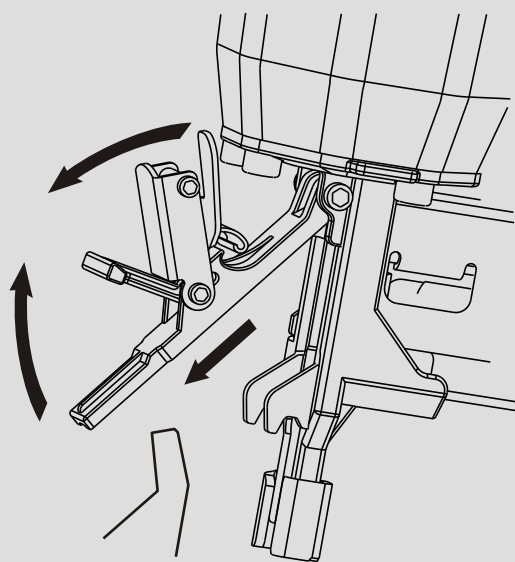

Manuale d'uso, manutenzione e parti di ricambio

Parte 2

Use, maintenance and spare parts manual

Part 2

Gebrauchsanweisung, Instandhaltungsrichtlinien und Ersatzteile

Teil 2

Manuel d'utilisation, entretien et pièces de rechange

Partie 2

Manual de uso, mantenimiento y repuestos

Part 2

Manual de utilização, manutenção e partes sobresselentes

Parte 2

Handleiding voor gebruik, onderhoud en reservedeelsite

Deel 2

Brugsanvisning, vedligeholdelse og reservedeelsite

Del 2



# M1.50

cod. 1828000

1828000\_M150\_2 130910 IV

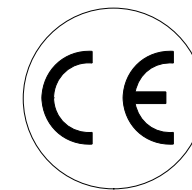

Dati tecnici Technical data Technische daten	Données techniques Datos tècnicos	Dados tècnicos Technischegegevens Teknische data
--	--------------------------------------	--

<b>Misure impiegabili mm</b> Usable lengths mm Gebrauchliche Längen mm	Mesures utilisable mm Medidas que se pueden emplear mm	Medidas que se podem utilizar mm Te gebruiken engtes in mm Brugbare laengder i mm	<b>20 ÷ 50</b>
--	---	---	----------------

<b>Capacità caricatore n° punti</b> Magazine capacity No. of fasteners Magazinkapazität Nägel	Capacité chargeur n° de points Capacidad cargador n° puntos	Capacidade carregador n° pontos Capaciteit magazijn in aantal spijkers Kapacitet af magasin antal klemme	<b>160</b>
---	--	--	------------

<b>Pressione d'esercizio</b> Working pressure Betriebsdruck	Pression de fonctionnement Presión de trabajo	Pressao de trabalho Werkdruk Arbejds tryk bar	<b>5 ÷ 7,5 bar 70 ÷ 105 psi</b>
---	--	---	-------------------------------------

<b>Consumo aria litri/colpo</b> Air consumption litres/shot Luftverbrauch Liter/Schlag	Consommation air litre/coup Consumo aire-litros/golpe	Consumo ar litro/golpe Luchtverbruik liter/schot Luftforbrug liter/skud	<b>1,40</b>
--	--	---	-------------

<b>Peso kg</b> Weight kg Gewicht kg	Poids kg Peso kg	Peso kg Gewicht in kg Vaegt kg	<b>2,25</b>
---	---------------------	--------------------------------------	-------------

<b>Dimensioni (AxBxH) mm</b> Dimensions mm Größe mm	Dimension mm Dimensiones mm	Dimensoes mm Afmetingen in mm Dimensioner mm	<b>354x98x282</b>
---	--------------------------------	--	-------------------

EN 12549 :1999 ISO 11201 :1995		L <sub>pA,1s</sub> (Rif. 20µPa)	
<b>Pressione sonora in pos. operatore</b> Sound pressure at the workstation Lärmintensität am Arbeitsplatz	Pression acoustique près de l'opérateur Presión sonora en posición encargado	Intensidade sonora perto do operador Geluidssterkte op de werkplek Lydstyrke på operatorposten	<b>86,7 dB(A)</b>

EN 12549 :1999 ISO 3744 :1994		L <sub>WA,1s</sub> (Rif. 1pW)	
<b>Potenza sonora emessa</b> Emitted sound power Ausgestrahlte Lärmintensität	Puissance acoustique émise Potencia sonora emitida	Potência sonora emitida Uitgestraalde geluidssterkte Udsendt lydstryrke	<b>97,9 dB(A)</b>

EN 28662 :1992 ISO 5349 :1986 ISO 8662 -11		Sequential a <sub>h,w</sub>	
<b>Valore medio ponderato di vibrazione sull'impugnatura</b> Weighted mean value of vibration on the grip Mitteler Vibrationswert, am Griff Gemessen	Valeur moyenne pondérée de vibration mesurée sur la poignée Valor medio ponderado de vibracion medida en la empunadura	Valor medio ponderado de vibracao medida no punho Gewogen gemiddelde vibratiewaarde	<b>4,65 m/s<sup>2</sup></b>
		Middelvaerdi af vibrationer pa handtaget	<b>4,75 m/s<sup>2</sup></b>

**Tipo di punto**  
Type of fastener  
Befestigungselement  
Type d'agrafe  
Tipo de punto  
Tipo de ponto  
Type nietjes  
Tilspændingstype

**M1**

1,30x1,45

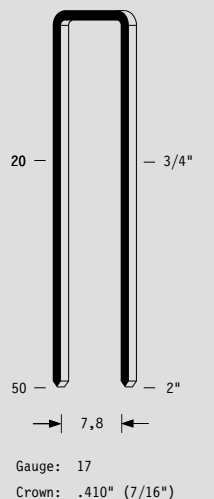

Parti di ricambio - Spare parts - Ersatzteile - Pièces de rechange - Piezas de repuesto  
- Partes sobresselentes - Tabel te raadplegen - Reservedele

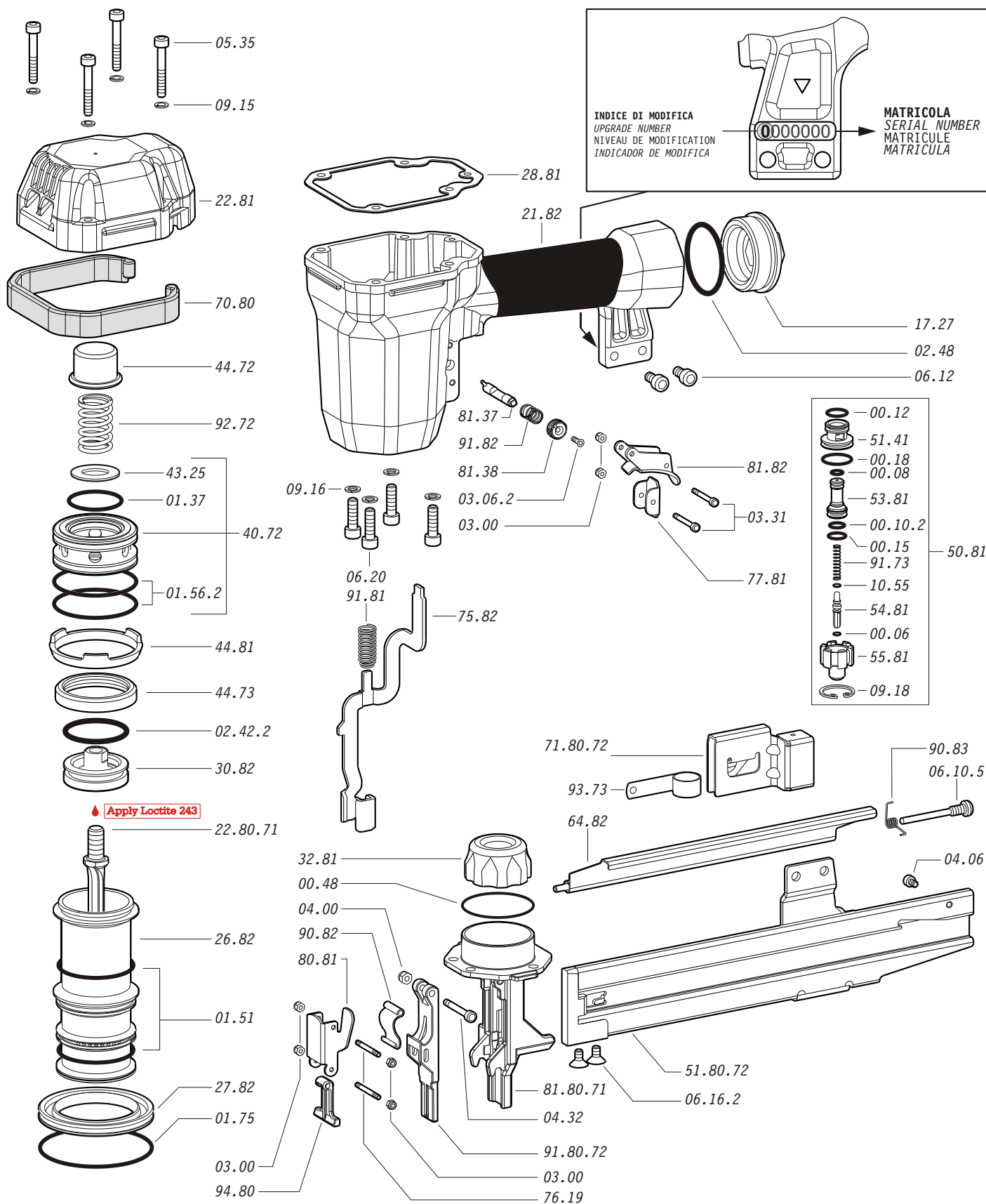

Dotazioni - Equipment - Ausrüstung - Équipements - Equipamiento -

Equipamento - Uitrusting - Udstyr

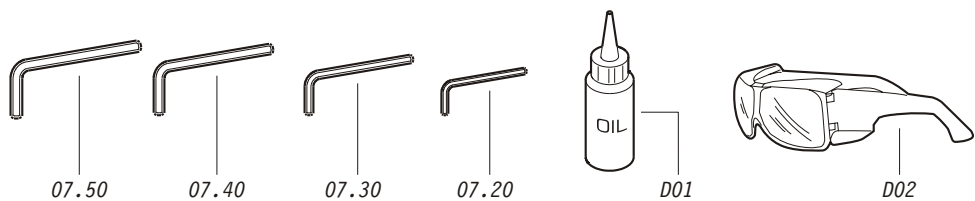

**M1.50**

cod. 1828000

Parti di ricambio - Spare parts - Ersatzteile - Pièces de rechange - Piezas de repuesto  
- Partes sobresselentes - Tabel te raadplegen - Reservedele

Cod.	Descrizione	Description
00.06	O-Ring	O-Ring
00.08	O-Ring	O-Ring
00.10.2	O-Ring	O-Ring
00.12	O-Ring	O-Ring
00.15	O-Ring	O-Ring
00.18	O-Ring	O-Ring
00.48	O-Ring	O-Ring
01.37	O-Ring	O-Ring
01.51	O-Ring	O-Ring
01.56.2	O-Ring	O-Ring
01.75	O-Ring	O-Ring
02.42.2	O-Ring	O-Ring
02.48	O-Ring	O-Ring
03.00	Dado	Nut
03.06.2	Vite	Screw
03.31	Vite	Screw
04.00	Dado	Nut
04.32	Vite	Screw
04.06	Vite	Screw
05.35	Vite	Screw
06.10.5	Vite	Screw
06.12	Vite	Screw
06.16.2	Vite	Screw
06.20	Vite	Screw
07.20	Chiave esagonale	Hex. bar wrench
07.30	Chiave esagonale	Hex. bar wrench
07.40	Chiave esagonale	Hex. bar wrench
07.50	Chiave esagonale	Hex. bar wrench
09.15	Rondella	Washer
09.16	Rondella	Washer
09.18	Anello elastico	Elastic ring
10.55	O-Ring	O-Ring
17.27	Tappo	Inlet cap
21.81	Corpo	Body
22.82	Testa	Head
26.82	Cilindro	Cylinder
27.82	Anello cilindro	Cylinder ring
28.81	Guarnizione testa	Head gasket
30.82	Pistone	Piston
32.81	Ammortizzatore	Bumper
40.72	Valvola completa	Valve ass'y
43.25	Rondella	Washer
44.72	Ammortizzatore	Bumper
44.73	Guarnizione cilindro	Cylinder gasket
44.81	Distanziale	Spacer
50.81	Pulsante completo	Trigger valve ass'y
51.41	Boccola pulsante	Trigger valve housing
53.81	Pistone servovalvola	Valve piston
54.81	Pulsante	Trigger valve
55.81	Raccordo pulsante	Bush
64.82	Carter	Hold down
70.80	Protezione	Guard
75.82	Sicura	Safety
76.19	Perno	Pin
77.81	Guida sicura	Safety guide
80.81	Grilletto testina	Nose plate lock
81.37	Perno selettore	Selecting pin
81.38	Pomello	Knob
81.82	Grilletto comando	Trigger
90.82	Molla	Spring
90.83	Molla	Spring
91.73	Molla	Spring
91.81	Molla	Spring
91.82	Molla	Spring
92.72	Molla	Spring
93.73	Molla	Spring
94.80	Tirante	Connecting rod
22.80.71	Battente	Driver
51.80.72	Caricatore	Magazine
71.80.72	Spingipunto	Pusher
81.80.71	Controtestina	Nose
91.80.72	Testina	Nose plate
D01	Bocchetta olio	Oiler
D02	Occhiali protettivi	Protective goggles

- Kit O-Rings - O-ringen - Pakninger

Guarnizioni - O-Rings - Dichtungen - Joints - Kit O-Rings -

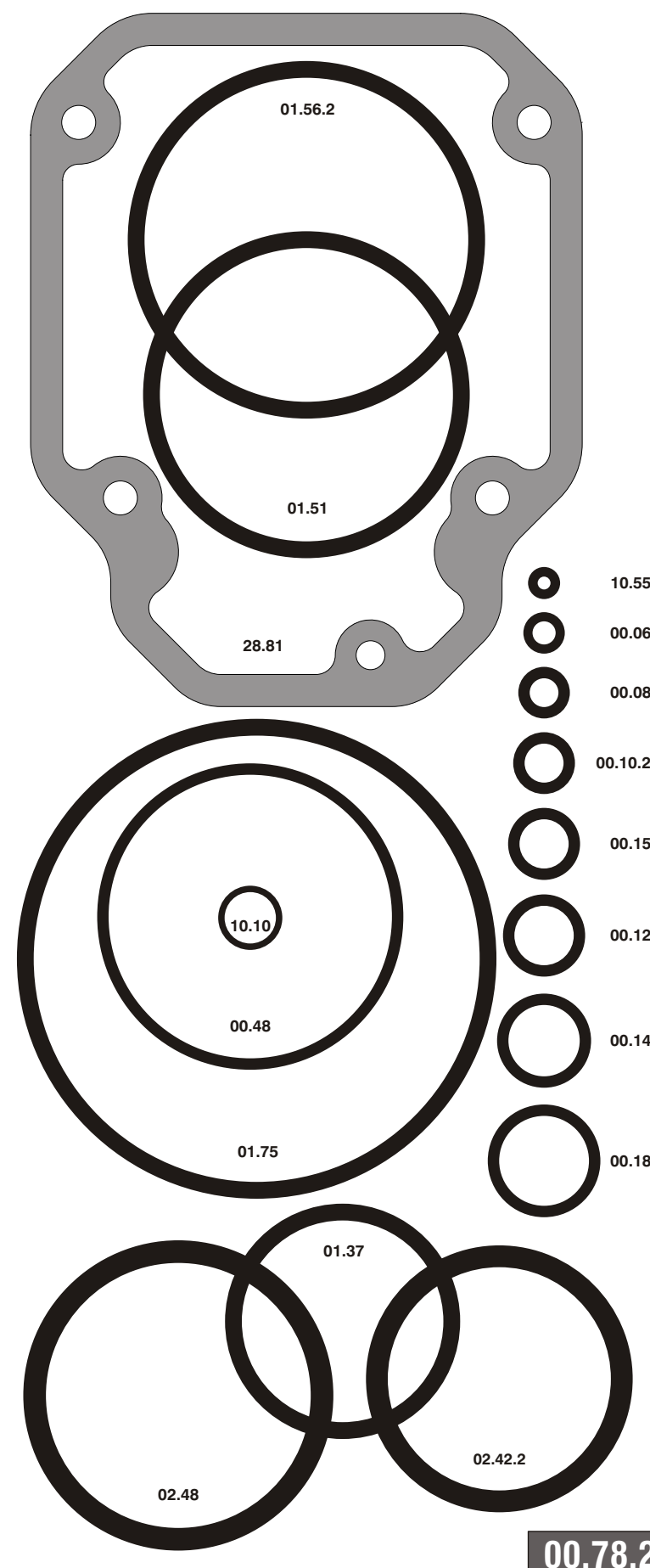

1828000\_M150\_2\_130910\_IV

**M1.50**

cod. 1828000

Indice di modifica Upgrade number **2**

1066087