

Caratteristiche - Features

Disinceppamento macchina Quick clearance jammed nails

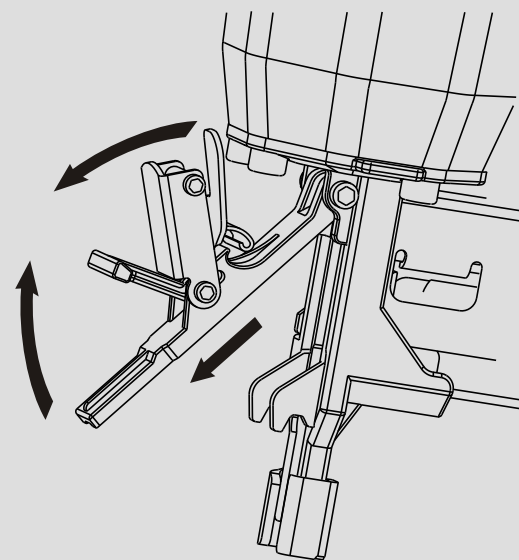

Colpo martello Bump fire

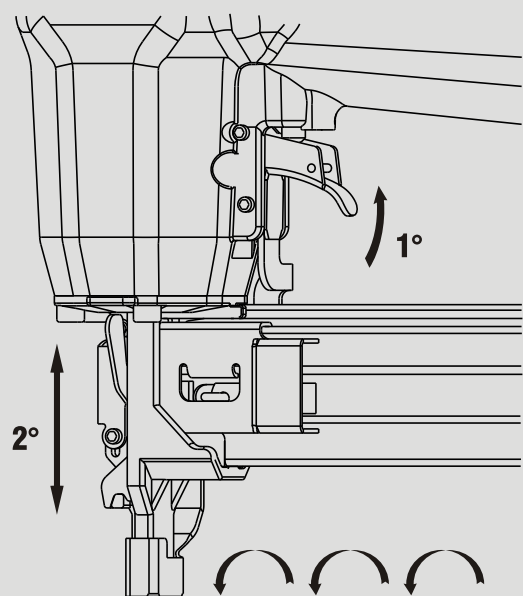

OMER

Manuale d'uso, manutenzione e parti di ricambio **Parte 2**
Use, maintenance and spare parts manual **Part 2**
Gebrauchsanweisung, Instandhaltungsrichtlinien und Ersatzteile **Teil 2**
Manuel d'utilisation, entretien et pièces de rechange **Partie 2**
Manual de uso, mantenimiento y repuestos **Part 2**

Manual de utilização, manutenção e partes sobresselentes **Parte 2**
Handleiding voor gebruik, onderhoud en reservedelslste **Deel 2**
Brugsanvisning, vedligeholdelse og reservedelslste **Del 2**



700.65

cod. 1828310

1828310_70065_2 051006 FL

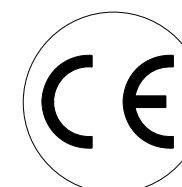

Dati tecnici Technical data Technische daten	Données techniques Datos tècnicos	Dados tècnicos Technischegegevens Tecniske data
--	--------------------------------------	---

Misure impiegabili mm Usable lengths mm Gebrauchliche Längen mm	Mesures utilisable mm Medidas que se pueden emplear mm	Medidas que se podem utilizar mm Te gebruiken engtes in mm Brugbare laengder i mm	20 ÷ 65
--	---	---	----------------

Capacità caricatore n° punti Magazine capacity No. of fasteners Magazinkapazität Nägel	Capacité chargeur n° de points Capacidad cargador n° puntos	Capacitade carregador n° pontos Capaciteit magazijn in aantal spijkers Kapacitet af magasin antal klemme	145
---	--	--	------------

Pressione d'esercizio Working pressure Betriebsdruck	Pression de fonctionnement Presión de trabajo	Pressao de trabalho Werkdruk Arbejds tryk bar	5 ÷ 7,5 bar 70 ÷ 105 psi
---	--	---	---

Consumo aria litri/colpo Air consumption litres/shot Luftverbrauch Liter/Schlag	Consommation air litre/coup Consumo aire-litros/golpe	Consumo ar litro/golpe Luchtverbruik liter/schot Luftforbrug liter/skud	1,40
--	--	---	-------------

Peso kg Weight kg Gewicht kg	Poids kg Peso kg	Peso kg Gewicht in kg Vaegt kg	2,10
---	---------------------	--------------------------------------	-------------

Dimensioni (AxBxH) mm Dimensions mm Größe mm	Dimension mm Dimensiones mm	Dimencoes mm Afmetingen in mm Dimensioner mm	355x98x282
---	--------------------------------	--	-------------------

EN 12549 :1999 ISO 11201 :1995		L _{pA,1s} (Rif. 20µPa)	
Pressione sonora in pos. operatore Sound pressure at the workstation Lärmintensität am Arbeitsplatz	Pression acoustique près de l'opérateur Presión sonora en posición encargado	Intensidade sonora perto do operador Geluidssterkte op de werkplek Lydstyrke på operatorposten	86,7 dB(A)

EN 12549 :1999 ISO 3744 :1994		L _{WA,1s} (rif. 1pW)	
Potenza sonora emessa Emitted sound power Ausgestrahlte Lärmintensität	Puissance acoustique émise Potencia sonora emitida	Potência sonora emitida Uitgestraalde geluidssterkte Udsendt lydstryke	97,9 dB(A)

EN 28662 :1992 ISO 5349 :1986 ISO 8662 -11		Sequential a _{h,w}	
Valore medio ponderato di vibrazione sull'impugnatura Weighted mean value of vibration on the grip Mitteler Vibrationswert, am Griff Gemessen	Valeur moyenne pondérée de vibration mesurée sur la poignée Valor medio ponderado de vibracion medida en la empunadura	Valor medio ponderado de vibracao medida no punho Gewogen gemiddelde vibratiewaarde Middelvaardi af vibrationer pa handtaget	4,65 m/s²
			Bump a_{h,w} 4,75 m/s²

Tipo di punto
Type of fastener
Befestigungselement
Type d'agrafe
Tipo de punto
Tipo de ponto
Type nietjes
Tilspændingstype

700

1,40x1,60

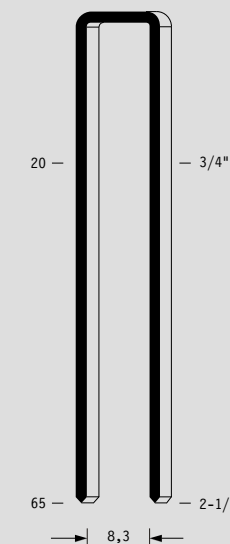

Gauge: 16
Crown: .437" (7/16")

