

Modalità sparo - Fire mode selection

Colpo martello Bump fire

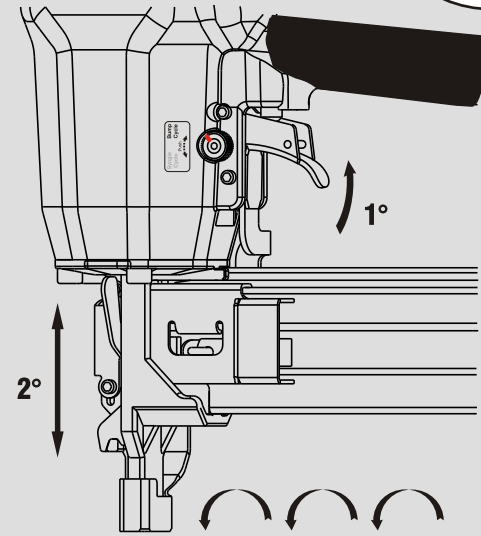

Colpo singolo Sequential fire

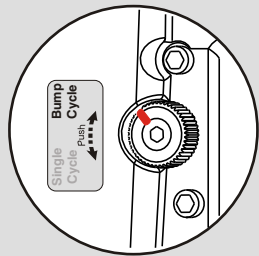
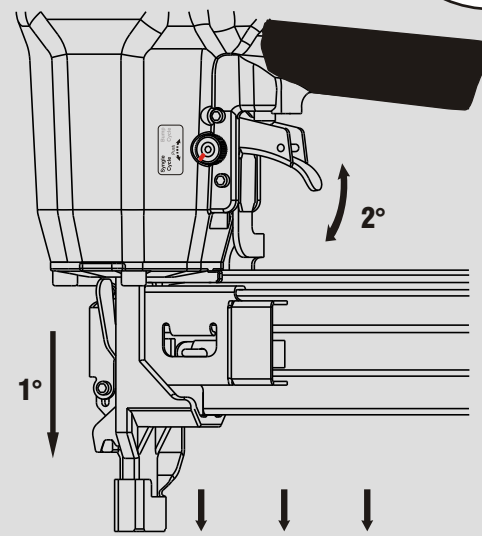
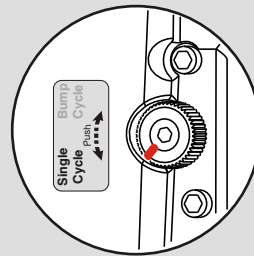

Caratteristiche - Features

Disinceppamento rapido macchina Quick clearance jammed nails

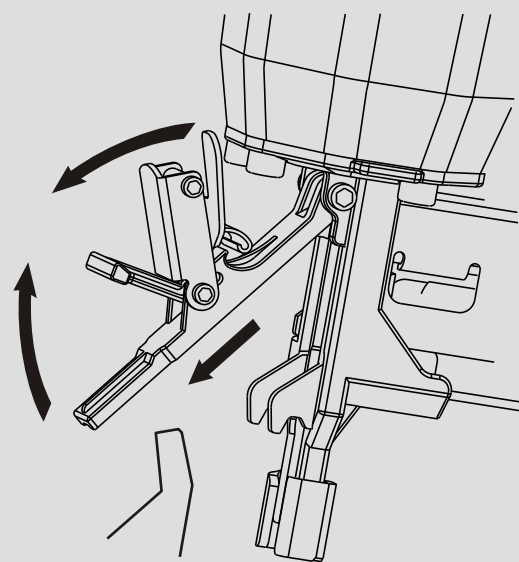

Acessori - Optional

Regolatore di profondità Depth adjustment

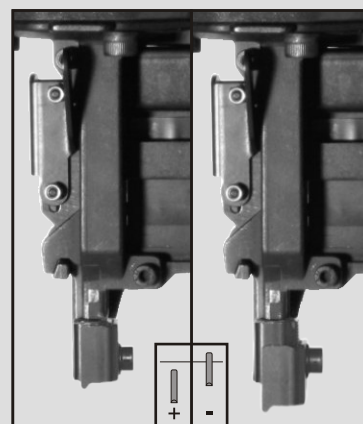

Cod. 75.82.2

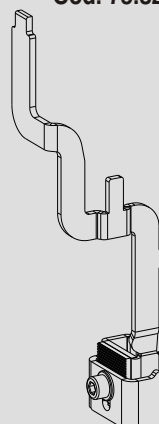

Manuale d'uso, manutenzione e parti di ricambio
Use, maintenance and spare parts manual
Gebrauchsanweisung, Instandhaltungsrichtlinien und Ersatzteile
Manuel d'utilisation, entretien et pièces de rechange
Manual de uso, mantenimiento y repuestos

Parte 2
Part 2
Teil 2
Partie 2
Part 2

Manual de utilização, manutenção e partes sobresselentes
Handleiding voor gebruik, onderhoud en reservedeelsite
Brugsanvisning, vedligeholdelse og reservedeelsite

Parte 2
Deel 2
Del 2



S4.65 SB

cod. 1838410SB

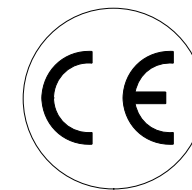

1838410SB_S465SB_3 130910 IV

Dati tecnici Technical data Technische daten	Données techniques Datos tècnicos	Dados tècnicos Technischegegevens Tecniske data
--	--------------------------------------	---

Misure impiegabili mm Usable lengths mm Gebrauchliche Längen mm	Mesures utilisable mm Medidas que se pueden emplear mm	Medidas que se podem utilizar mm Te gebruiken engtes in mm Brugbare laengder i mm	20 ÷ 65
Capacità caricatore n° punti Magazine capacity No. of fasteners Magazinkapazität Nägel	Capacité chargeur n° de points Capacidad cargador n° puntos	Capacitade carregador n° pontos Capaciteit magazijn in aantal spijkers Kapacitet af magasin antal klemme	145
Pressione d'esercizio Working pressure Betriebsdruck	Pression de fonctionnement Presión de trabajo	Pressao de trabalho Werkdruk Arbejds tryk bar	5 ÷ 7,5 bar 70 ÷ 105 psi
Consumo aria litri/colpo Air consumption litres/shot Luftverbrauch Liter/Schlag	Consommation air litre/coup Consumo aire-litros/golpe	Consumo ar litro/golpe Luchtverbruik liter/schot Luftforbrug liter/skud	1,40
Peso kg Weight kg Gewicht kg	Poids kg Peso kg	Peso kg Gewicht in kg Vaegt kg	2,10
Dimensioni (AxBxH) mm Dimensions mm Größe mm	Dimension mm Dimensiones mm	Dimencoes mm Afmetingen in mm Dimensioner mm	355x98x282

EN 12549 :1999 ISO 11201 :1995		L _{pA,1s} (Rif. 20µPa)	
Pressione sonora in pos. operatore Sound pressure at the workstation Lärmintensität am Arbeitsplatz	Pression acoustique près de l'opérateur Presión sonora en posición encargado	Intensidade sonora perto do operador Geluidssterkte op de werkplek Lydstyrke på operatorposten	86,7 dB(A)

EN 12549 :1999 ISO 3744 :1994		L _{WA,1s} (rif. 1pW)	
Potenza sonora emessa Emitted sound power Ausgestrahlte Lärmintensität	Puissance acoustique émise Potencia sonora emitida	Potência sonora emitida Uitgestraalde geluidssterkte Udsendt lydstryrke	97,9 dB(A)

EN 28662 :1992 ISO 5349 :1986 ISO 8662 -11		Sequential a _{h,w}	
Valore medio ponderato di vibrazione sull'impugnatura Weighted mean value of vibration on the grip Mitteler Vibrationswert, am Griff Gemessen	Valeur moyenne pondérée de vibration mesurée sur la poignée Valor medio ponderado de vibracion medida en la empunadura	Valor medio ponderado de vibracao medida no punho Gewogen gemiddelde vibratiewaarde	4,65 m/s²
		Middelvaerdi af vibrationer pa handtaget	4,75 m/s²

Tipo di punto
Type of fastener
Befestigungselement
Type d'agrafe
Tipo de punto
Tipo de ponto
Type nietjes
Tilspændingstype

S4

1,40x1,60

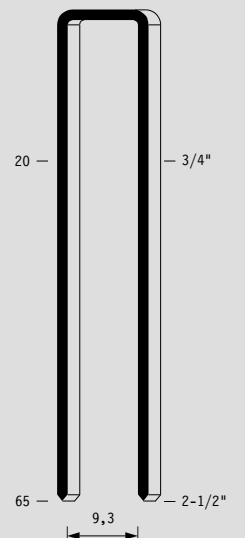

Gauge: 16
Crown: .476" (1/2")

Parti di ricambio - Spare parts - Ersatzteile - Pièces de rechange - Piezas de repuesto
- Partes sobresselentes - Tabel te raadplegen - Reservedele

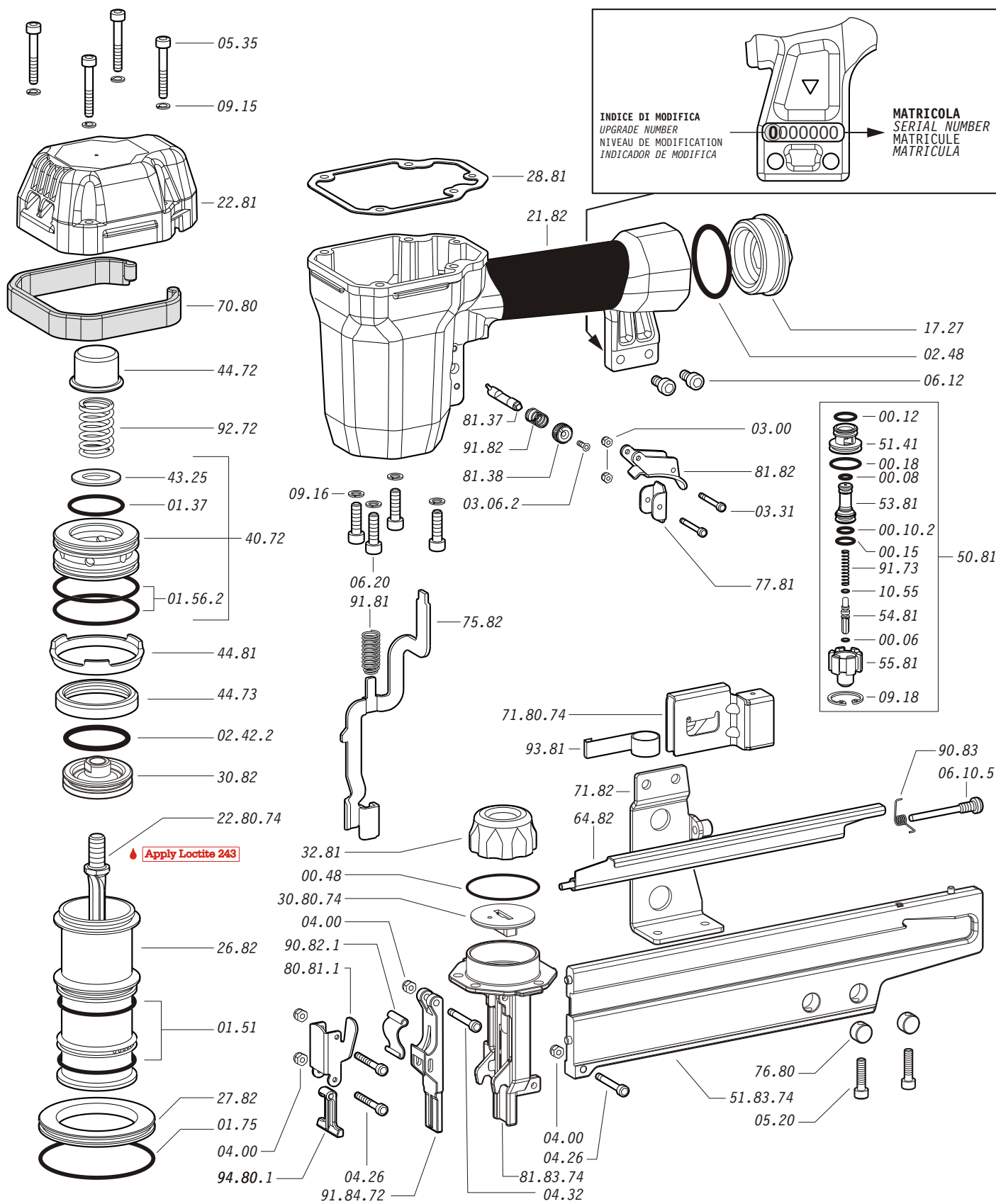

Dotazioni - Equipment - Ausrüstung - Équipements - Equipamiento -

Equipamento - Uitrusting - Udstyr

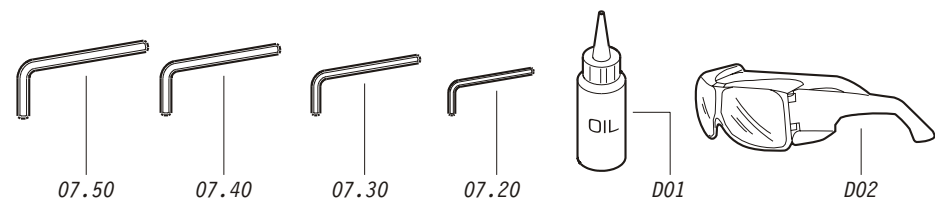

S4.65 SB

cod. 1838410SB

Parti di ricambio - Spare parts - Ersatzteile - Pièces de rechange - Piezas de repuesto
- Partes sobresselentes - Tabel te raadplegen - Reservedele

Cod.	Descrizione	Description
00.06	O-Ring	O-Ring
00.08	O-Ring	O-Ring
00.10.2	O-Ring	O-Ring
00.12	O-Ring	O-Ring
00.15	O-Ring	O-Ring
00.18	O-Ring	O-Ring
00.48	O-Ring	O-Ring
01.37	O-Ring	O-Ring
01.51	O-Ring	O-Ring
01.56.2	O-Ring	O-Ring
01.75	O-Ring	O-Ring
02.42.2	O-Ring	O-Ring
02.48	O-Ring	O-Ring
03.00	Dado	Nut
03.06.2	Vite	Screw
03.31	Vite	Screw
04.00	Dado	Nut
04.26	Vite	Screw
04.32	Vite	Screw
05.20	Vite	Screw
05.35	Vite	Screw
06.10.5	Vite	Screw
06.12	Vite	Screw
06.20	Vite	Screw
07.20	Chiave esagonale	Hex. bar wrench
07.30	Chiave esagonale	Hex. bar wrench
07.40	Chiave esagonale	Hex. bar wrench
07.50	Chiave esagonale	Hex. bar wrench
09.15	Rondella	Washer
09.16	Rondella	Washer
09.18	Anello elastico	Elastic ring
10.55	O-Ring	O-Ring
17.27	Tappo	Inlet cap
21.82	Corpo	Body
22.81	Testa	Head
26.82	Cilindro	Cylinder
27.82	Anello cilindro	Cylinder ring
28.81	Guarnizione testa	Head gasket
30.82	Pistone	Piston
32.81	Ammortizzatore	Bumper
40.72	Valvola completa	Valve ass'y
43.25	Rondella	Washer
44.72	Ammortizzatore	Bumper
44.73	Guarnizione cilindro	Cylinder gasket
44.81	Distanziale	Spacer
50.81	Pulsante completo	Trigger valve ass'y
51.41	Boccola pulsante	Trigger valve housing
53.81	Pistone servovalvola	Valve piston
54.81	Pulsante	Trigger valve
55.81	Raccordo pulsante	Bush
64.82	Carter	Hold down
70.80	Protezione	Guard
71.82	Reggicaricatore	Support
75.82	Sicura	Safety
76.80	Inserto	Nut screw
77.81	Guida sicura	Safety guide
80.81.1	Grilletto testina	Nose plate lock
81.37	Perno selettore	Selecting pin
81.38	Pomello	Knob
81.82	Grilletto comando	Trigger
90.82.1	Molla	Spring
90.83	Molla	Spring
91.73	Molla	Spring
91.81	Molla	Spring
91.82	Molla	Spring
92.72	Molla	Spring
93.81	Molla	Spring
94.80.1	Tirante	Connecting rod
22.80.74	Battente	Driver
30.80.74	Guida battente	Driver Guide
51.83.74	Caricatore	Magazine
71.80.74	Spingipunto	Pusher
81.83.74	Controtestina	Nose
91.84.72	Testina	Nose plate
D01	Bocchetta olio	Oiler
D02	Occhiali protettivi	Protective goggles

- Kit O-Rings - O-ringen - Pakninger

Guarnizioni - O-Rings - Dichtungen - Joints - Kit O-Rings -

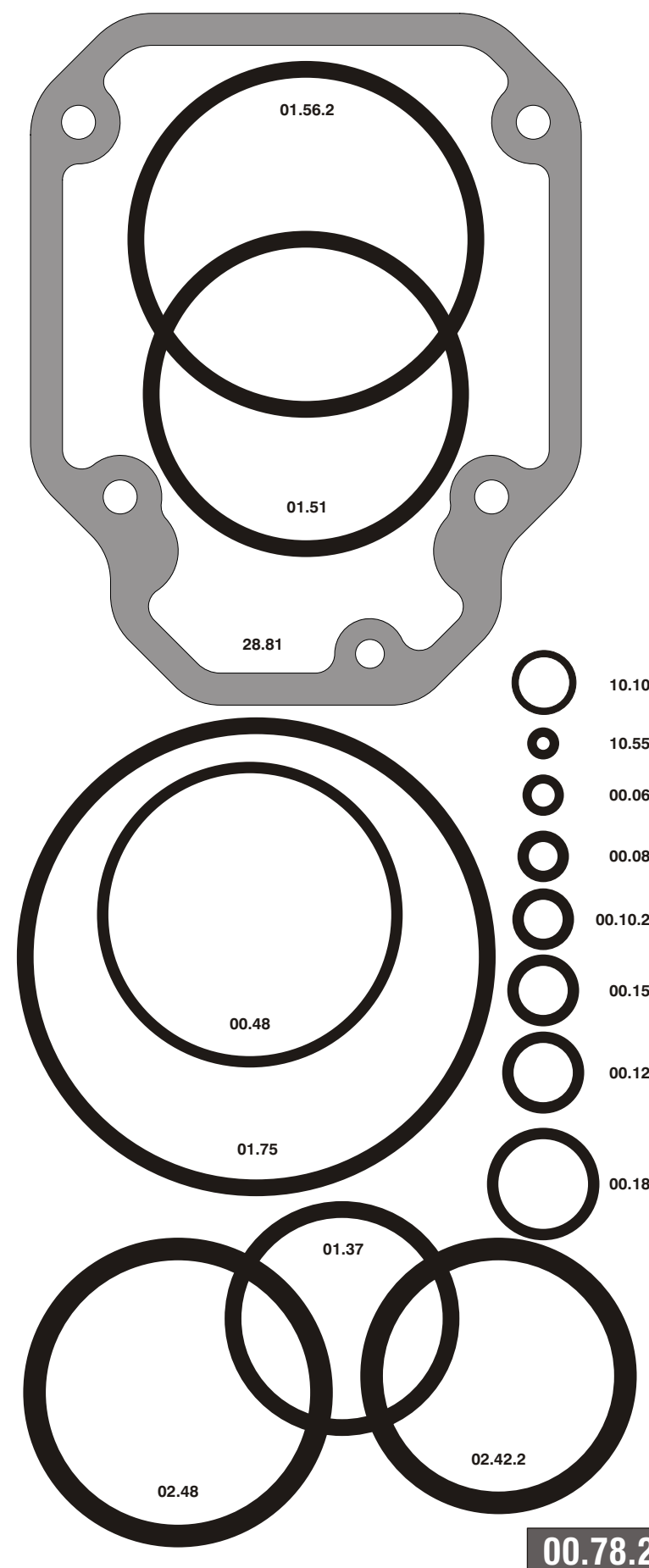

1838410SB_S465SB_3_130910_IV

S4.65 SB

cod. 1838410SB

Indice di modifica
Upgrade number

3

3270647