



# オマー社 ハンマータッカー G-19

cod. 100G19

## 分解図及び部品名称

**Misure impiegabili mm (inch)**  
Usable lengths mm (inch) **6 ÷ 10**  
(1/4" ÷ 3/8")

**Capacità caricatore n° punti**  
Magazine capacity No. of fasteners **157**

**Peso kg**  
Weight kg **0,41**

**Dimensioni (AxBxH) mm**  
Dimensions mm **274x32x53**

**Tipo di punto**  
Type of fastener

**113**

0,50x0,75

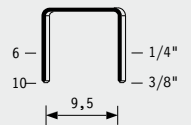

Gauge: 23

Crown: .413" (13/32")

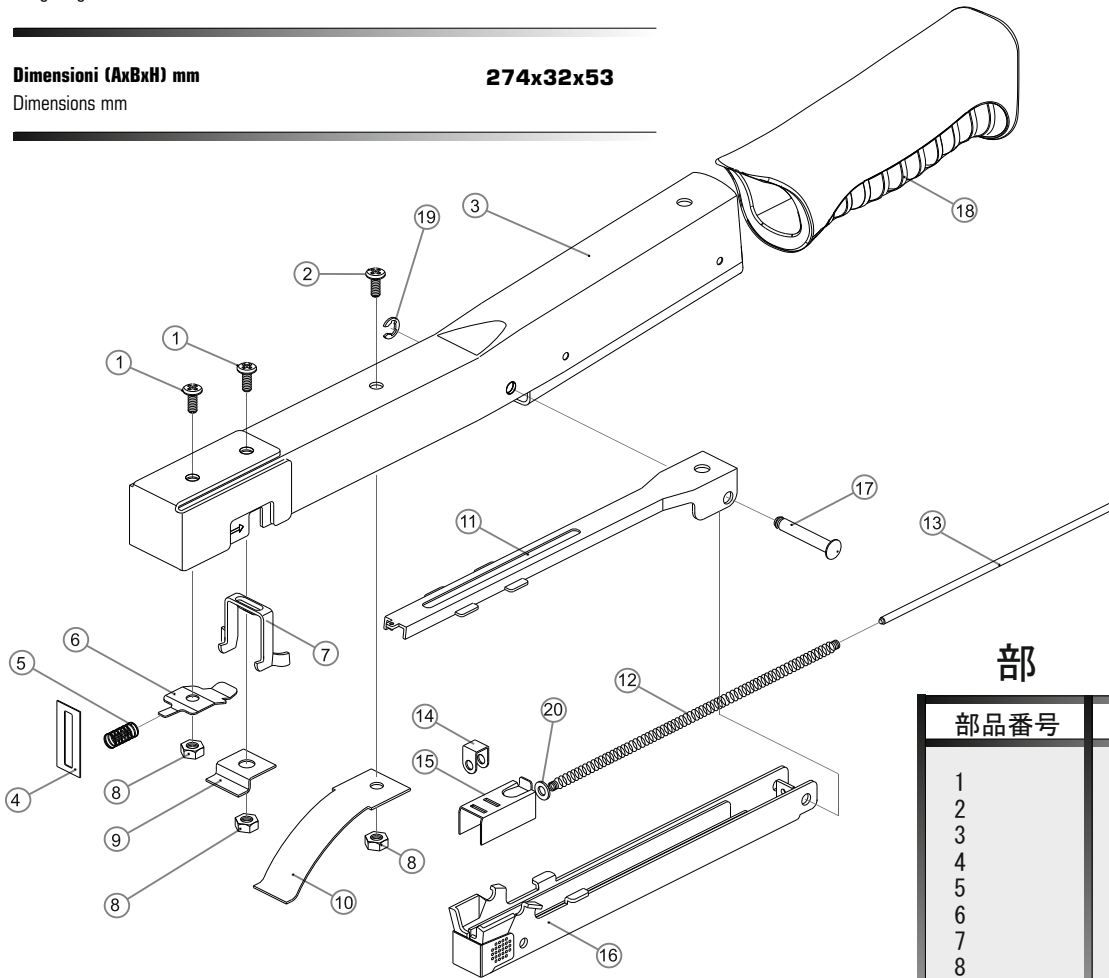

## 部品表

部品番号	部品名
1	ビス
2	ビス
3	本体アッセンブリ
4	ドライバー
5	ドライバースプリング
6	フックスプリング
7	フック
8	ロックナット
9	フックホルダー
10	ハンドル板ばね
11	マガジンカバー
12	プッシャースプリング
13	プッシャーバー
14	プッシャーロック
15	プッシャー
16	マガジン
17	マガジンピン
18	グリップ
19	Eリング ER-3.0x7
20	皿ばねワッシャー

Distributed by

**omer** s.p.a.

Via Foresto 42 - 31058 SUSEGANA TV ITALY Tel.0438455318 Fax 0438455530

E-mail: omer@omer.it

www.omer.it



# G-19

cod. 100G19

**Misure impiegabili mm (inch)**

Usable lengths mm (inch)

**6 ÷ 10**  
**(1/4" ÷ 3/8")**

**Capacità caricatore n° punti**

Magazine capacity No. of fasteners

**157**

**Peso kg**

Weight kg

**0,41**

**Dimensioni (AxBxH) mm**

Dimensions mm

**274x32x53**

**Tipo di punto**  
Type of fastener

**113**

0,50x0,75

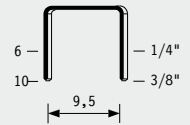

Gauge: 23

Crown: .413" (13/32")

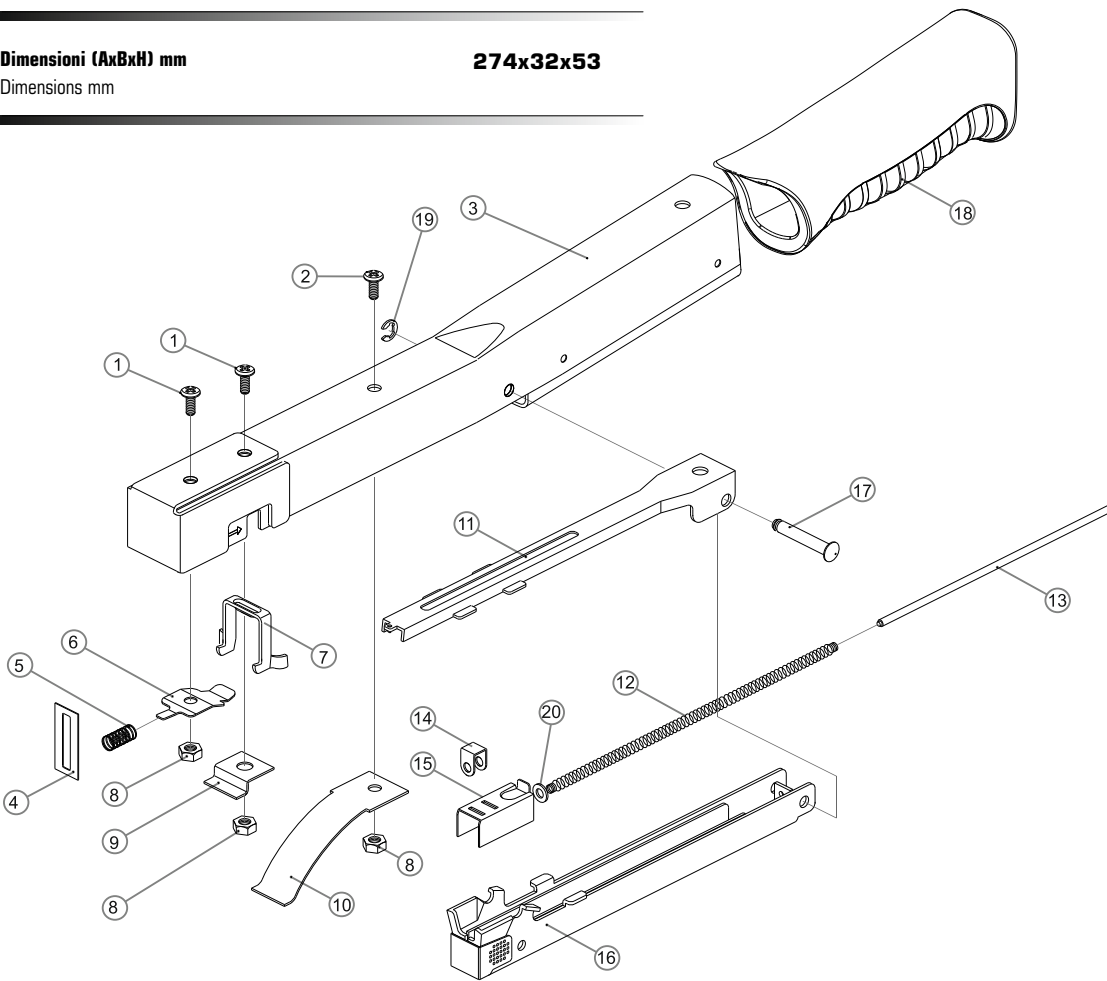

Ref.	Part No.	Descrizione	Description
1	G19-01	Vite	Screw
2	G19-02	Vite	Screw
3	G19-03	Corpo	Body assembly
4	G19-04	Battente	Driver
5	G19-05	Molla	Spring
6	G19-06	Piastra battente	Driver plate
7	G19-07	Piastra gancio	Hook plate
8	G19-08	Dado	Nut
9	G19-09	Piastra	Press plate
10	G19-10	Molla	Spring plate

Ref.	Part No.	Descrizione	Description
11	G19-11	Copri caricatore	Magazine
12	G19-12	Molla	Pusher spring
13	G19-13	Stelo	Pusher pole
14	G19-14	Fermo	Clamp
15	G19-15	Spingipunto	Pusher
16	G19-16	Caricatore	Staple magazine
17	G19-17	Perno	Pin
18	G19-18	Grip	Grip
19	G19-19	E-ring	E-ring
20	G19-20	Rondella	Washer

Distributed by

**omer** s.p.a.

Via Foresto 42 - 31058 SUSEGANA TV ITALY Tel.0438455318 Fax 0438455530

E-mail: omer@omer.it

www.omer.it