

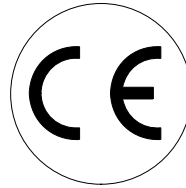

Manuale d'uso, manutenzione e parti di ricambio	Parte 2
Manual for use, maintenance and spare parts	Part 2
Bedienungs- und Wartungshandbuch sowie Ersatzteilliste	Teil 2
Mode d'emploi, de maintenance et pièces de rechange	Partie 2
Manual de uso, mantenimiento y recambios	Part 2
Εγχειρίδιο χρήσης, συντήρησης και ανταλλακτικών	Μέρος 2
Manual de uso, manutenção e peças sobresselentes	Parte 2
Handleiding voor gebruik, onderhoud en wisselstukken	Deel 2
Kullanım, bakım ve yedek parça kılavuzu	Kısım 2

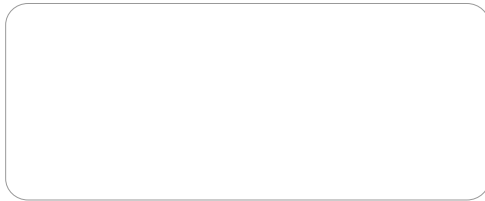

MB.35 (SIDE-ARM)

cod. 1029830

Dati tecnici Technical data Technische Daten	Caractéristiques techniques Datos técnicos Τεχνικά χαρακτηριστικά	Dados técnicos Technische gegevens Teknik veriler
Misure impiegabili mm Lengths mm Verwendbare Nagellänge mm	Dimensions utiles mm Medidas de longitud mm Μήκος Αναλωσίμου - mm	Medidas utilizáveis mm Toepasbare afmetingen mm Boy mm
		15÷22
Capacità caricatore n° punti Magazine capacity Magazinkapazität Nägel	Capacité chargeur n° de points Capacidad cargador n° puntos Δυνατοτητα γεμιστερα	Capacidade carregador n° pontos Capaciteit magazijn in aantal spijkers Dergi kapasitesi
		200
Peso kg Weight kg Gewicht kg	Poids kg Peso kg Βάρος - kg	Peso kg Gewicht in kg Ağırlık kg
		31,60
Dimensioni mm Dimensions mm Abmessungen mm	Dimensions mm Dimensiones mm Διαστάσεις mm	Dimensões mm Afmetingen mm Boyutlar mm
		760x550x1250 (LxWxH)

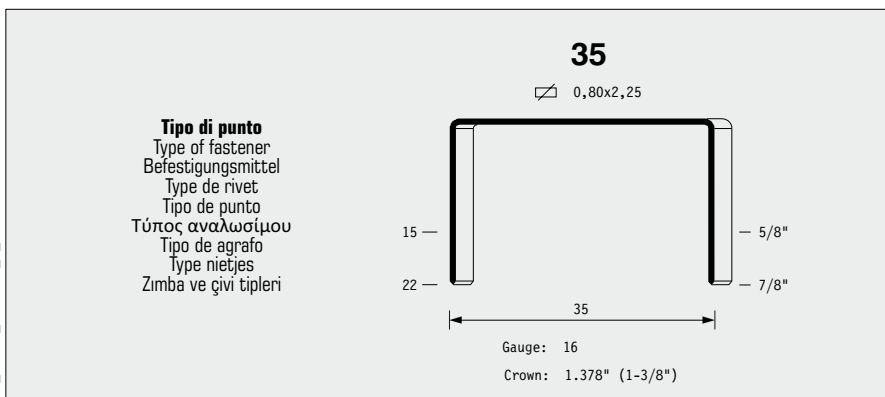
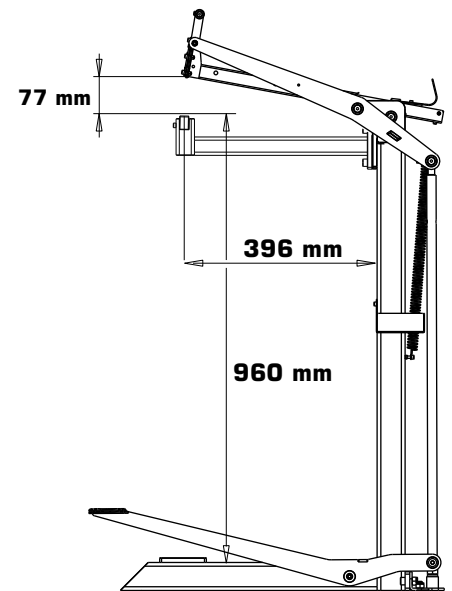

1029830_MB35_sidearm_3_rev20_15/09/2020_LA

Parti di ricambio - Spare parts - Ersatzteile - Pièces de rechange - Recambios
 Ανταλλακτικά - Partes sobresselentes - Wisselstukken - Yedek parçalar

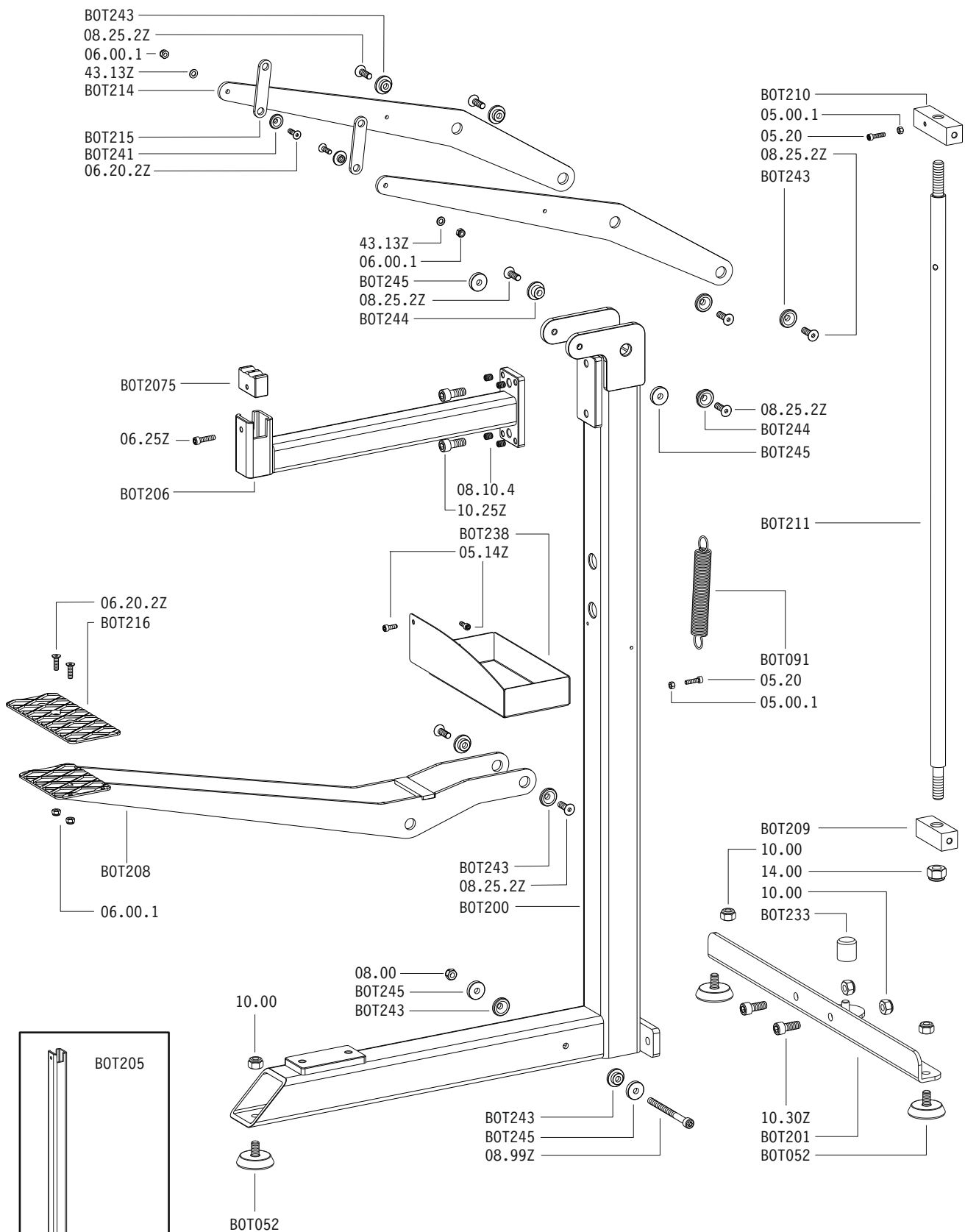

BOT205

A richiesta
On request

MB.35

cod. 1029830

Parti di ricambio - Spare parts - Ersatzteile - Pièces de rechange - Recambios
Ανταλλακτικά - Partes sobresselentes - Wisselstukken - Yedek parçalar

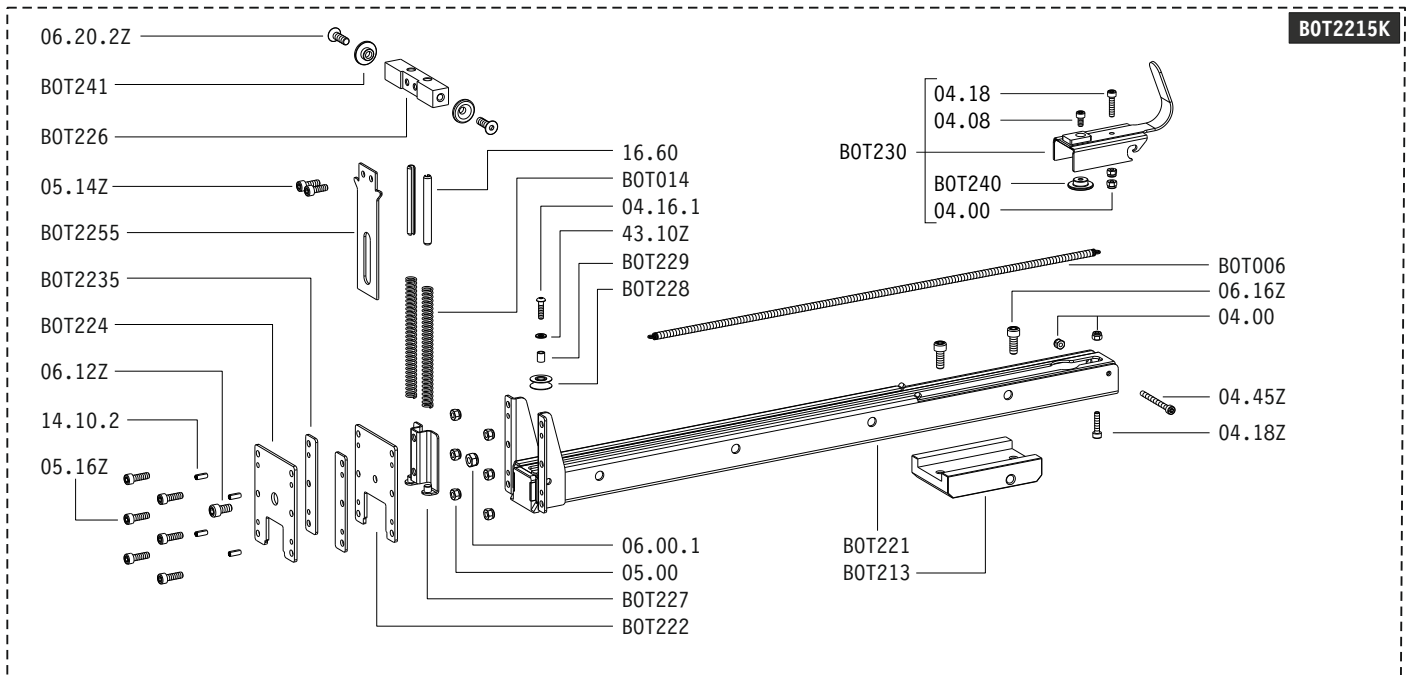

Cod.	Descrizione	Description	Cod.	Descrizione	Description
04.00	Dado	Nut	BOT014	Molla	Spring
04.08	Vite	Screw	BOT052	Piedino	Socle
04.16.1	Vite	Screw	BOT091	Molla	Spring
04.18Z	Vite	Screw	BOT200	Telaio	Frame Body
04.18	Vite	Screw	BOT201	Supporto	Support
04.45Z	Vite	Screw	BOT205	Braccio Vericale	Vertical Arm
05.00	Dado	Nut	BOT206	Braccio Orizzontale	Orizzontal Arm
05.00.1	Dado	Nut	BOT2075	Incudine	Anvil
05.14Z	Vite	Screw	BOT208	Pedale	Foot Lever
05.16Z	Vite	Screw	BOT209	Traversa Inferiore	Lower Cross Bar
05.20	Vite	Screw	BOT210	Traversa Superiore	Upper Cross Bar
06.00.1	Dado	Nut	BOT211	Tirante	Connecting Rod
06.12Z	Vite	Screw	BOT213	Supporto Caricatore	Magazine Support
06.16Z	Vite	Screw	BOT214	Leva	Lever
06.20.2Z	Vite	Screw	BOT215	Biella	Connecting Rod
06.25Z	Vite	Screw	BOT216	Piastra	Plate
07.13	Chiave esagonale	Wrench	BOT221	Caricatore	Magazine
07.30	Chiave esagonale	Hex. bar wrench	BOT2215K	KIT Caricatore	Magazine KIT
07.40	Chiave esagonale	Hex. bar wrench	BOT222	Piastra Posteriore	Rear Plate
07.50	Chiave esagonale	Hex. bar wrench	BOT2235	Guida Battente	Driver Guide
07.60	Chiave esagonale	Hex. bar wrench	BOT224	Piastra Anteriore	Front Plate
07.80	Chiave esagonale	Hex. bar wrench	BOT2255	Battente	Driver
08.00	Dado	Nut	BOT226	Porta Battente	Driver Holder
08.10.4	Vite	Screw	BOT227	Carter	Carter
08.25.2Z	Vite	Screw	BOT228	Carrucola	Pulley
08.99Z	Vite	Screw	BOT229	Distanziale	Spacer
10.00	Dado	Nut	BOT230	Spingipunto	Pusher
10.25Z	Vite	Screw	BOT233	Ammortizzatore	Bumper
10.30Z	Vite	Screw	BOT238	Vaschetta	Staple Container
14.00	Dado	Nut	BOT240	Distanziale	Spacer
14.10.2	Spina	Pin	BOT241	Bussola	Bush
16.60	Spina	Pin	BOT243	Bussola	Bush
43.10Z	Rondella	Washer	BOT244	Bussola	Bush
43.13Z	Rondella	Washer	BOT245	Distanziale	Spacer
BOT006	Molla	Spring			

MB.35

cod. 1029830

Indice di modifica
Upgrade number

3

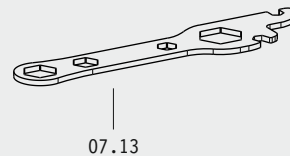
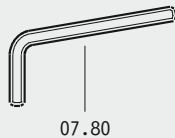
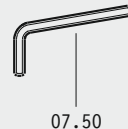

Messa in funzione della pedalina - Installation of the unit

Assemblaggio parti :

Part assembling :

La bottomer è imballata con molla, vaschetta, piastra pedale e il supporto trasversale smontato. Per mettere in funzione la pedalina montare il supporto trasversale alla base, la vaschetta al telaio, la molla come indicato da figura e infine montare la piastra nella posizione scelta.

The bottomer is shipped with spring, staple case, foot lever plate and the the transversal support dismantled. To put in function the unit fasten the support at the base, the staple case at the frame body, the spring as shown in picture and then fasten the foot lever plate in the choosen position.

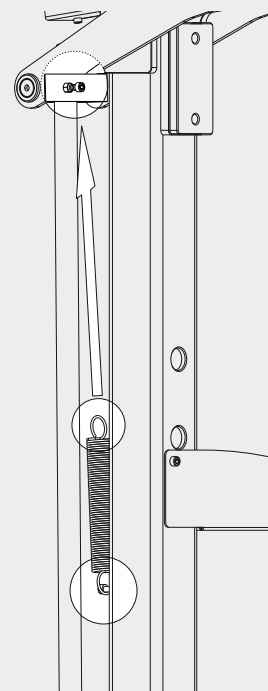
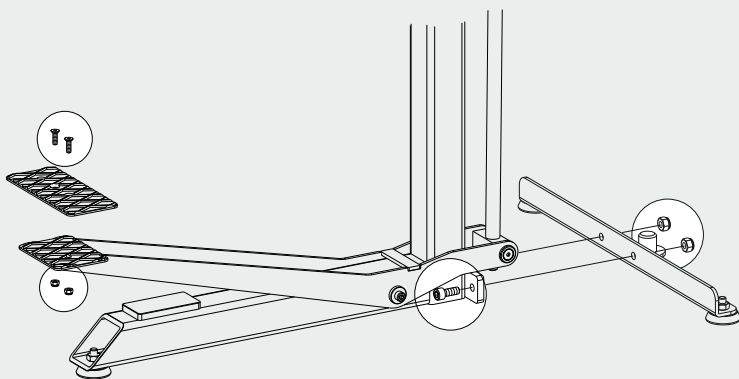
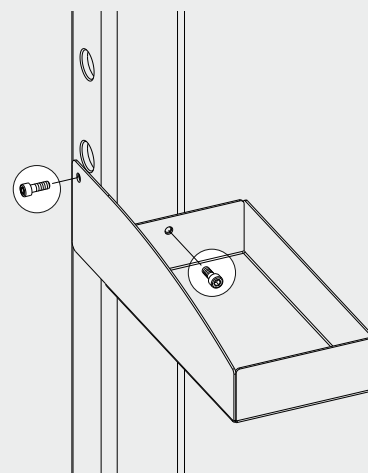

Posizionamento piastra pedale :

Foot lever plate postioning :

Per un più comodo utilizzo è possibile spostare la piastra pedale in 3 posizioni diverse, per fare ciò svitare le viti che fissano la piastra al pedale e riavvitarle nella posizione scelta 1, 2 o 3.

For a better utilization it's possible to chose 3 configuration for the foot lever plate, to do this unscrew the screw from the plate and remount them in the chosen position 1, 2 or 3.

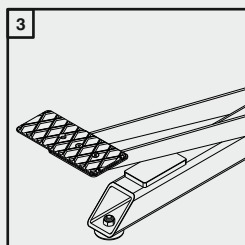
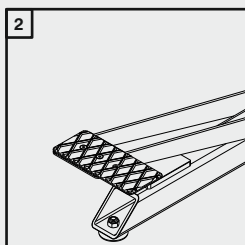
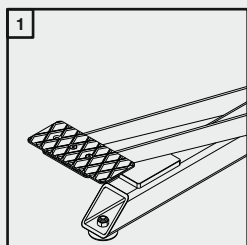

- **Arretrare lo spingipunto ① e agganciarlo alla vite finecorsa ②.**

Pull the pusher backwards ① and hook it at the stop position at the rear of the tool ②.

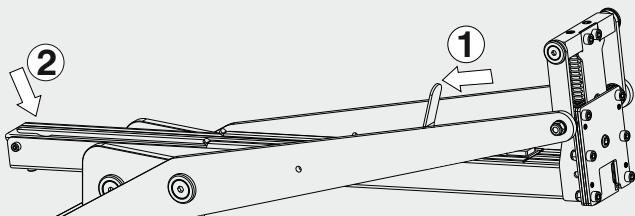

- **Inserire le graffe, quindi rilasciare lo spingipunto ③.**

Load the magazine with staples, then release the pusher ③.

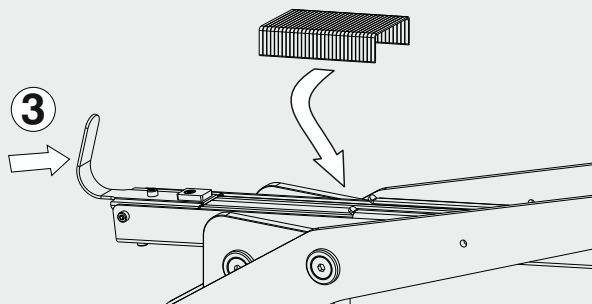

Regolazioni - Adjustment

Centratura incudine :

Anvil alignment :

- **Allentare le viti ① che fissano il braccio al telaio.**

Loose the screws ① that fasten the arm at the frame body.

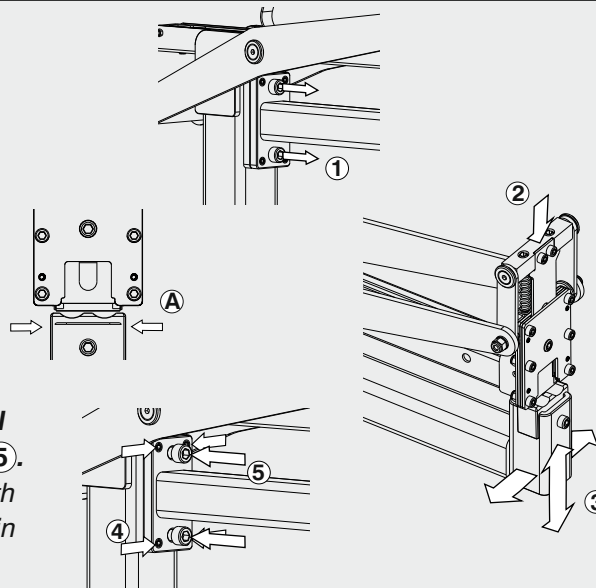

- **Con testa abbassata ②, centrare l'incudine A rispetto al battente ③ agendo sui grani ④, infine richiudere le viti ⑤.**

While the stapling head is lowered ②, center the anvil A with the driver blade ③ by operating the screws ④, tighten again the screws ⑤.

Graffatura :

Stapling :

- **Allentare il dado che blocca il tirante alla traversa inferiore.**

Loose the nut that fasten the connecting rod at the lower cross bar.

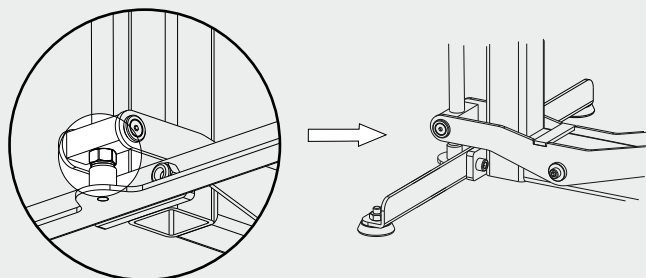

- **Con un perno inserito nell'apposito foro ruotare il tirante fino a trovare il tipo di graffatura desiderata e richiudere il dado di blocco.**

With a pin inserted in the apposit hole adjust the connecting rod till finding the wished stapling and tighten again the locking nut.

+ **Stringe la graffatura**
Tighten the stapling



- **Allenta la graffatura**
Loose the stapling

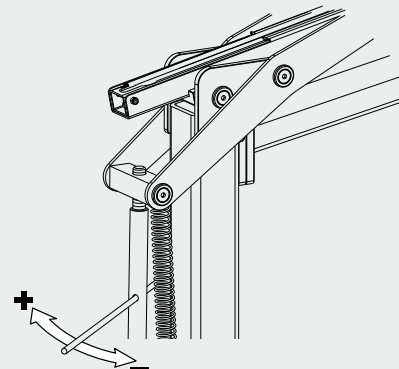



Istruzioni di Sicurezza - Safety Instructions



IMPORTANTE NON DISTRUGGERE !

Leggere attentamente questo manuale prima di usare la graffatrice e rispettare le norme di sicurezza qui contenute.

Introduzione

Allo scopo di assicurare la massima affidabilità di esercizio, la OMER spa ha effettuato un'accurata scelta dei materiali e dei componenti da impiegare nella costruzione dell'utensile, sottoponendolo a regolare collaudo prima della consegna. Il buon rendimento nel tempo della graffatrice dipende anche da un corretto uso e da un'adeguata manutenzione preventiva.

Tutti gli elementi costruttivi, gli organi di collegamento e comando sono stati progettati e realizzati con un grado di sicurezza tale da poter resistere a sollecitazioni superiori a quelle del normale utilizzo.

Condizioni d'uso previste dal costruttore

La graffatrice è stata progettata esclusivamente per la chiusura di scatole in cartone.

Non si deve usare la macchina né eseguire su di essa alcun intervento, se prima non si è accuratamente letto e compreso questo manuale.

Azionare la graffatrice SOLO dopo aver posizionato il cartone da chiudere.

Si fa divieto di impiegare la macchina per un uso diverso da quanto indicato.

La OMER spa non può essere ritenuta responsabile per guasti, inconvenienti o infortuni dovuti alla non ottemperanza a questo divieto.

Norme di sicurezza

- Non permettere l'uso della graffatrice a bambini o a persone non competenti.
- Non utilizzare la graffatrice se vi sono parti danneggiate.
- Non piantare punti metallici su altri già messi in precedenza.
- Mentre si opera tenere distante le mani dalla zona di cucitura.

IMPORTANT KEEP IN A SAFE PLACE!

Read this manual carefully before using the stapler. All safety instructions must be strictly observed.

Introduction.

In order to assure the top working reliability, OMER has made a careful choice of the materials and components used in the manufacture of the tool that has been tested before delivery. Performances and durability of the tool in time depend on its proper use and adequate servicing according to the instructions provided with this manual. All components of the tool and its working devices have been designed and tested to provide the highest safety standards to withstand much severe stresses than usually involved with the regular use of the tool under the conditions set in this manual.

Conditions of use prescribed by the manufacturer.

The tool is strictly and exclusively designed for closing cardboard boxes.

Never use the tool or do any maintenance or repair without reading and understanding what stated in this manual.

Activate the tool only after leaning the cardboard box you are willing to close.

Never use the tool under conditions or for applications not set in this manual.

OMER won't be liable for failures, breakdowns or accidents caused by not observing this rule.

Safety instructions:

- Do not allow children or unskilled person to use the tool.
- Never use the tool when knowing that any of the part is damaged.
- Never drive staples on top of those driven earlier.
- While operating keep hand away from the stapled area

GARANZIA

La OMER spa si impegna a sostituire gratuitamente, per tutta la durata della chiodatrice, i particolari che saranno riconosciuti, a giudizio dei tecnici della casa costruttrice, soggetti a difetto del materiale o di fabbricazione. Non saranno sostituiti in garanzia i componenti soggetti alla normale usura dovuta al funzionamento.

La presente garanzia decade qualora vengano rilevate anomalie di funzionamento o rotture non causate da difetti di fabbricazione ma imputabili ad un uso dell'utensile non conforme alle norme indicate dal costruttore. Gli eventuali costi di trasporto saranno sempre e comunque a carico del cliente.

GUARANTEE

OMER spa undertakes to replace free of charge any parts which its engineers acknowledge to be faulty due to manufacturing or material defects, during the life of the machine. The guarantee does not cover any components subject to normal wear and tear during operation. This guarantee is void if malfunction or breakage are due not to manufacturing faults but to an improper use of the tool, not in conformity with the manufacturer's instructions. Freight charges are always at the buyer's expense.