

### Azionamento continuo

Continual actuation

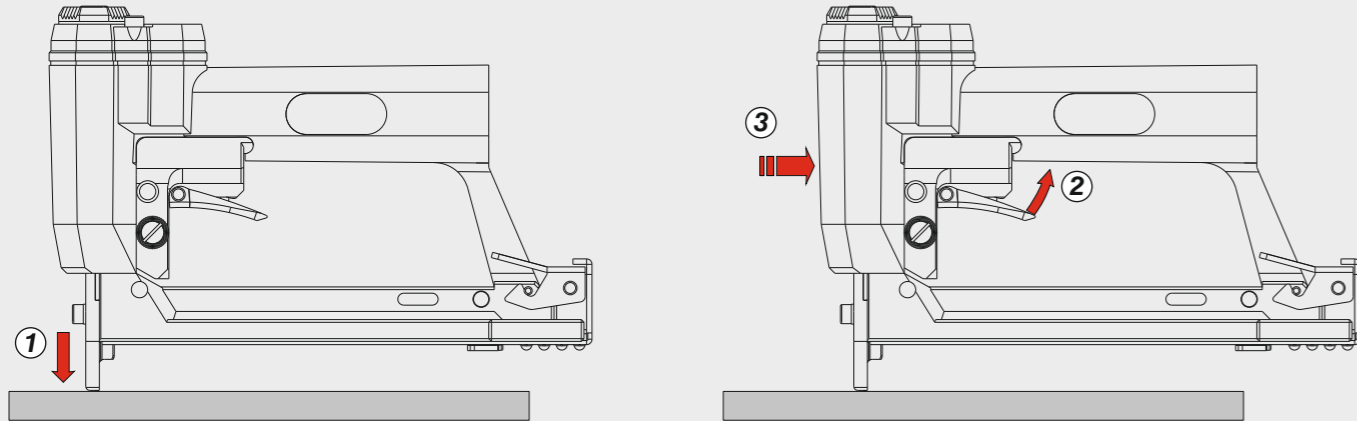

### Azionamento singolo

Single actuation

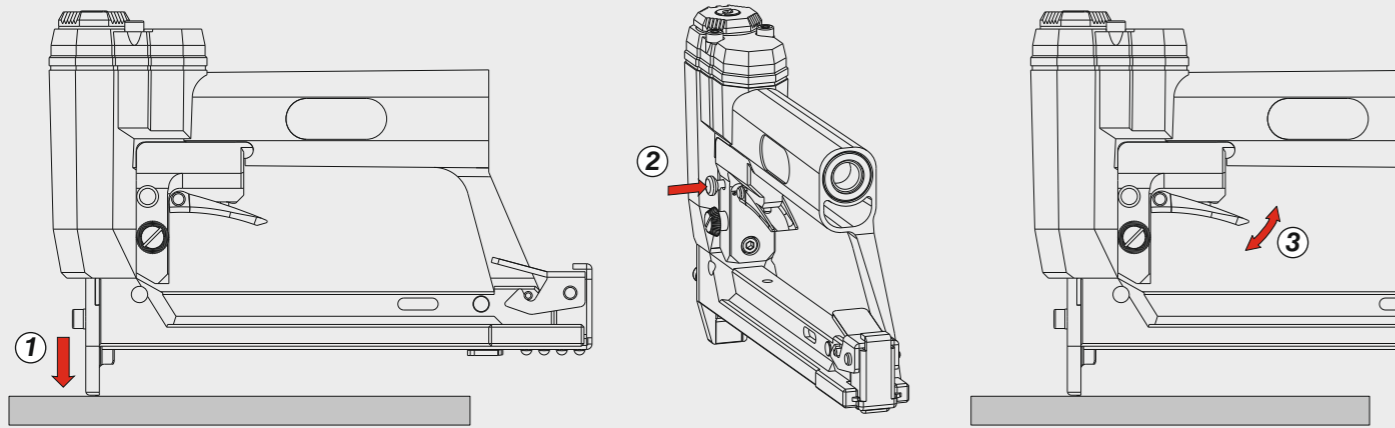

Caricamento - Loading - Laden - Chargement - Carga - Γέμισμα - Carregamento - Laden - Yükleme

### Caricamento da sotto

Bottom load magazine

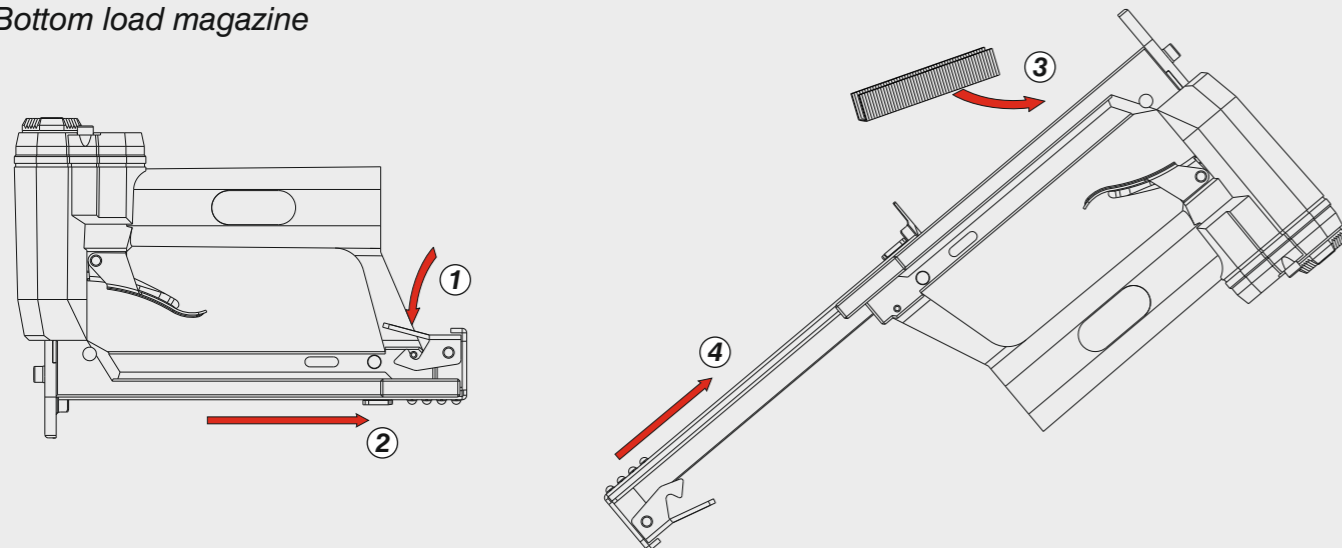

Manuale d'uso, manutenzione e parti di ricambio	Parte 2
Manual for use, maintenance and spare parts	Part 2
Bedienungs- und Wartungshandbuch sowie Ersatzteilleiste	Teil 2
Mode d'emploi, de maintenance et pièces de rechange	Partie 2
Manual de uso, mantenimiento y recambios	Part 2
Εγχειρίδιο χρήσης, συντήρησης και ανταλλακτικών	Μέρος 2
Manual de uso, manutenção e peças sobresselentes	Parte 2
Handleiding voor gebruik, onderhoud en wisselstukken	Deel 2
Kullanım, bakım ve yedek parça kılavuzu	Kısım 2



# 3G FV

cod. 108432800



Dati tecnici Technical data Technische Daten	Caractéristiques techniques Datos técnicos Τεχνικά χαρακτηριστικά	Dados técnicos Technische gegevens Teknik veriler
<b>Misure impiegabili mm</b> Lengths mm Verwendbare Nagellänge mm	Dimensions utiles mm Medidas de longitud mm Μήκος Αναλωσίμου - mm	Medidas utilizáveis mm Toepasbare afmetingen mm Boy mm
<b>Capacità caricatore n° punti</b> Magazine capacity Magazinkapazität Nägel	Capacité chargeur n° de points Capacidad cargador n° puntos Δωανατοτητα γεμιστερα	Capacidade carregador n° pontos Capaciteit magazijn in aantal spijkers Dergi kapasitesi
<b>Pressione d'esercizio</b> Operating pressure Betriebsdruck	Pression d'exercice Presión de servicio Πίεση λειτουργίας	Pressão de serviço Werkdruk Çalışma basıncı
<b>Consumo aria litri/colpo</b> Air consumption litres/stroke Luftverbrauch Liter/Schuss	Consommation d'air litres/coup Consumo aire litros/golpe Κατανάλωση αέρα - λίτρα/βολή	Consumo ar litros/disparo Luchtverbruik liter/slag Litre/vuruş hava tüketimi
<b>Peso kg</b> Weight kg Gewicht kg	Poids kg Peso kg Βάρος - kg	Peso kg Gewicht in kg Ağırlık kg
<b>Dimensioni mm</b> Dimensions mm Abmessungen mm	Dimensions mm Dimensiones mm Διαστάσεις mm	Dimensões mm Afmetingen mm Boyutlar mm
<b>UNI EN 12549 :2009</b> <b>UNI EN ISO 4871 :2009</b>	<b>Pressione sonora in pos. operatore</b> Sound pressure in operator's position Schalldruck am Arbeitsplatz	Pressão sonora na posição Operador Geluidsdruk op de werkplaats Operatör pozisyonunda ses basıncı
<b>UNI EN 12549 :2009</b> <b>UNI EN ISO 3746 :2011</b> <b>UNI EN ISO 4871 :2009</b>	<b>Potenza sonora emessa</b> Sound power emitted Emittierte Schalleistung	Potência sonora emitida Geëmitteerd geluidsvermogen Çıkan ses gücü (ses desibel)
<b>UNI CEN ISO/TS 8662-11 :2006</b> <b>UNI EN ISO 5349-2 :2004</b> <b>UNI EN 12096 :1999</b>	<b>Emissione vibratoria sull'impugnatura</b> Vibratory emissions on handle Vibrationsemission am Griff	Emissão vibratória na empunhadura Trillingsemissie op de handgreep Tutamak üzerinde vibrasyon emisyonları

**Tipo di punto**  
Type of fastener  
Befestigungsmittel  
Type de rivet  
Τύπος αναλωσίμου  
Tipo de agrafa  
Type nietjes  
Zimba ve çivi tipleri

**3G**

0,55x0,75

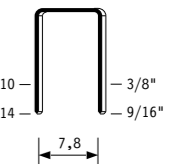

Crown: .350" (11/32")  
Gauge: 23

Parti di ricambio - Spare parts - Ersatzteile - Pièces de rechange - Recambios  
Ανταλλακτικά - Partes sobresselentes - Wisselstukken - Yedek parçalar

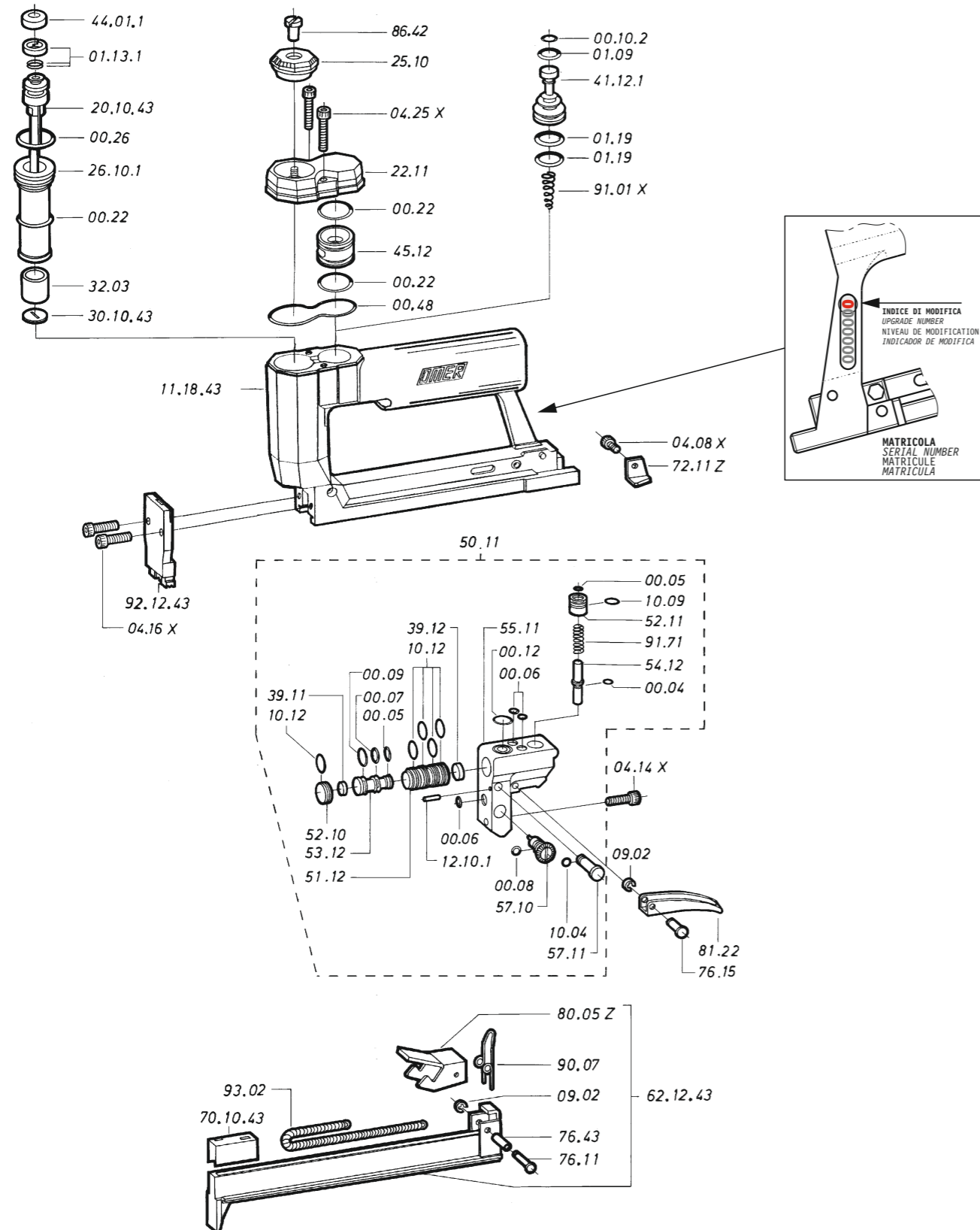

Dotazioni - Equipment - Ausstattung - Outillage - Dotaciones - Εξοπλισμός  
Dotações - Uitrusting - Donanımlar



**3G FV**

cod. 108432800

Parti di ricambio - Spare parts - Ersatzteile - Pièces de rechange - Recambios  
Ανταλλακτικά - Partes sobresselentes - Wisselstukken - Yedek parçalar

Cod.	Descrizione	Description
00.04	O-Ring	O-Ring
00.05	O-Ring	O-Ring
00.06	O-Ring	O-Ring
00.07	O-Ring	O-Ring
00.08	O-Ring	O-Ring
00.09	O-Ring	O-Ring
00.10.2	O-Ring	O-Ring
00.12	O-Ring	O-Ring
00.22	O-Ring	O-Ring
00.26	O-Ring	O-Ring
00.48	O-Ring	O-Ring
01.09	O-Ring	O-Ring
01.13.1	Guarnizione	Gasket
01.19	O-Ring	O-Ring
04.08Z	Vite	Screw
04.14	Vite	Screw
04.16Z	Vite	Screw
04.25Z	Vite	Screw
07.30	Chiave esagonale	Hex. Bar wrench
09.02	Anello elastico	Elastic ring
10.04	O-Ring	O-Ring
10.09	O-Ring	O-Ring
10.12	O-Ring	O-Ring
12.10.1	Spina	Pin
22.11	Testa	Head
25.10	Deflettore	Exhaust deflector
26.10.1	Cilindro	Cylinder
32.03	Ammortizzatore	Bumper
39.11	Guarnizione servov.	Valve gasket
39.12	Ammortizzatore	Bumper
41.12.1	Pistone valvola	Valve
44.01.1	Ammortizzatore	Bumper
45.12	Anello valvola	Ring
50.11	Dispositivo completo	Assembled device
51.12	Cilindro servovalvola	Servo valve cylinder
52.10	Tappo	Inlet cap
52.11	Boccola	Bushing
53.12	Pistone servovalvola	Valve piston
54.12	Pulsante	Trigger valve
55.11	Corpo servovalvola	Valve body
57.10	Regolatore	Regulator
57.11	Interruttore	Switch
72.11Z	Fermo carrello	Slider stop
76.11	Perno	Pin
76.15	Perno	Pin
76.43	Perno	Pin
80.05Z	Grilletto chiusura	Trigger
81.22	Grilletto comando	Trigger
86.42	Vite deflettore	Deflector screw
90.07	Molla	Spring
91.01X	Molla	Spring
91.71	Molla	Spring
93.02	Molla	Spring
11.18.43	Corpo	Body
20.10.43	Battente	Driver
30.10.43	Rondella	Washer
62.12.43	Carrello	Slider
70.10.43	Spingipunto	Pusher
92.12.43	Testina	Nose plate

Guarnizioni - O-Rings - Dichtungen - Joints toriques - Junta - Δακτύλιος στεγανοποίησης - Vedantes - O-ringen - Contalar

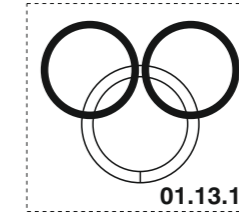

00.04

00.05

00.06

00.07

00.08

00.09

00.10.2

00.12

00.14

00.22

00.26

00.48

00.71.2

**3G FV**

cod. 108432800

Indice di modifica  
Upgrade number

**8**

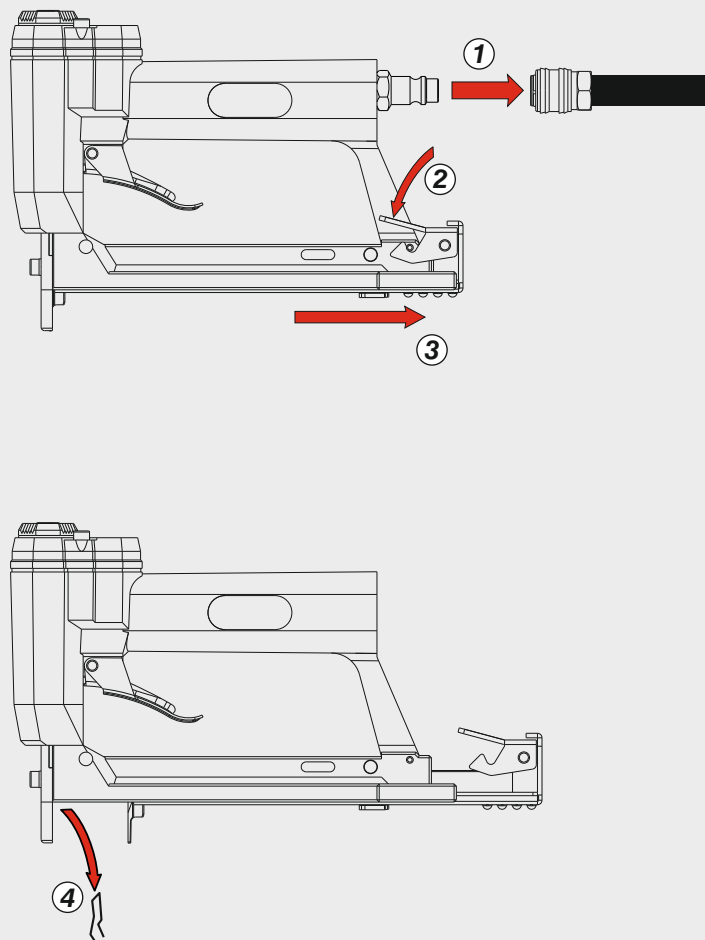

**Scarico orientabile a 360°**  
360° adjustable exhaust

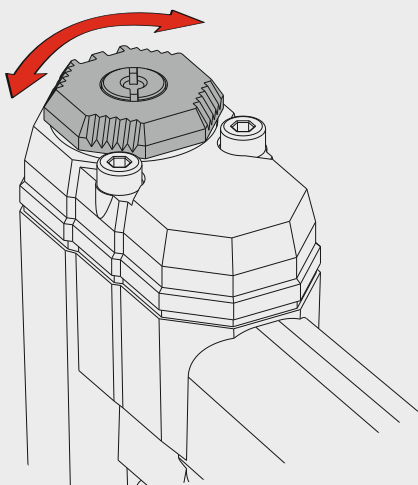

**Regolazione della velocità**  
Speed adjustment

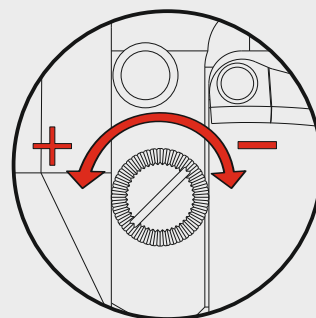

Max 1400 rpm

