

Collegamento - Connection

Collegamento:
Connection:

Valvola 3/2 NC
Valve 3/2 NC

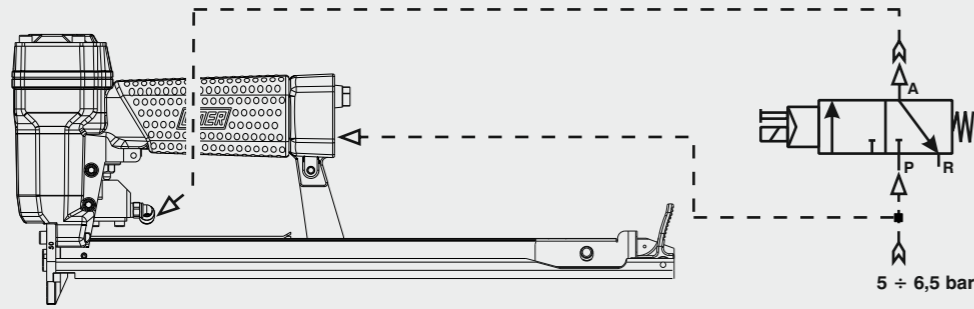

Caricamento - Loading - Laden - Chargement - Carga - Γέμισμα - Carregamento - Laden - Yükleme

Caricamento da sopra
Top load magazine

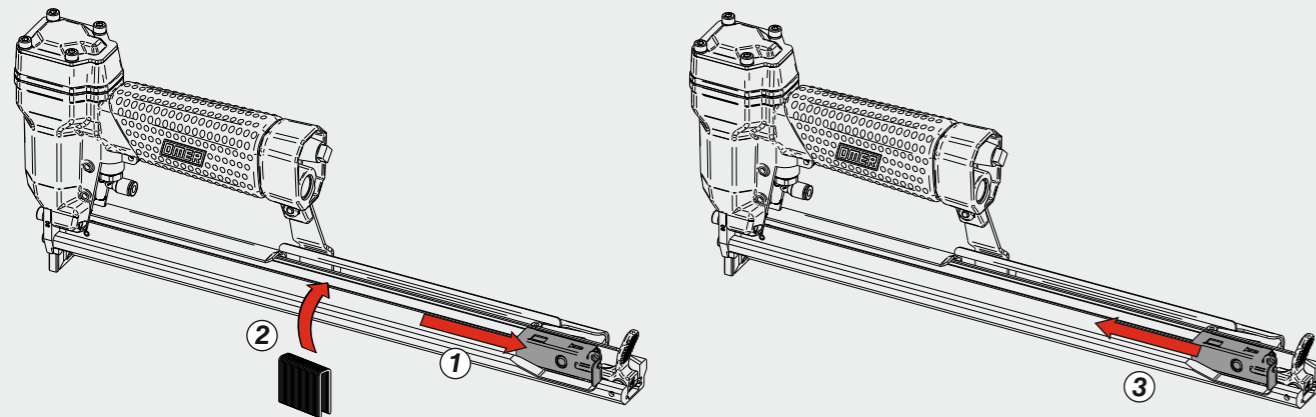

Disinceppamento - Jam clearing - Staubeseitigung - Décoincement - Desatascamiento - Απεμπλοκή
Desencravamento - Deblokkering bij vastlopen - Sıkışma giderme

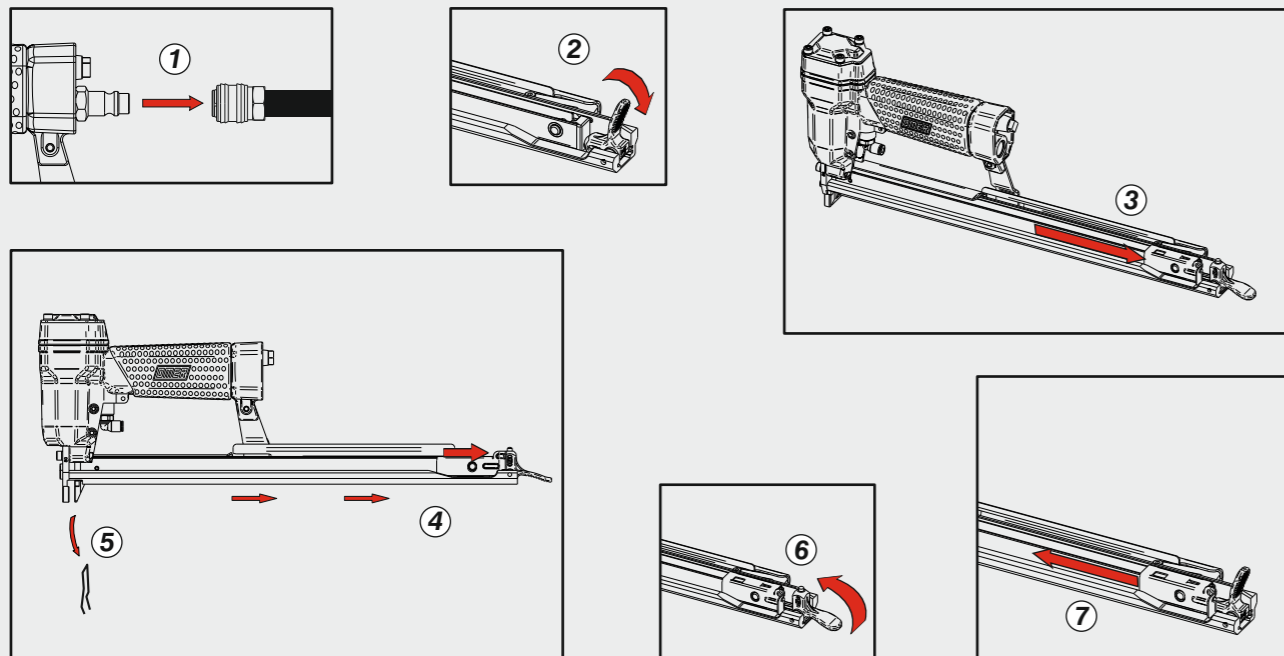

OMER®

Manuale d'uso, manutenzione e parti di ricambio
Manual for use, maintenance and spare parts
Bedienungs- und Wartungshandbuch sowie Ersatzteilleiste
Mode d'emploi, de maintenance et pièces de rechange
Manual de uso, mantenimiento y recambios
Εγχειρίδιο χρήσης, συντήρησης και ανταλλακτικών
Manual de uso, manutenção e peças sobresselentes
Handleiding voor gebruik, onderhoud en wisselstukken
Kullanım, bakım ve yedek parça kılavuzu

Parte 2
Part 2
Teil 2
Partie 2
Part 2
Μέρος 2
Parte 2
Deel 2
Kısım 2



3G.16 CLT-3

cod. 11543540-3

Dati tecnici Technical data Technische Daten	Caractéristiques techniques Datos técnicos Τεχνικά χαρακτηριστικά	Dados técnicos Technische gegevens Teknik veriler
Misure impiegabili mm Lengths mm Verwendbare Nagellänge mm	Dimensions utiles mm Medidas de longitud mm Μήκος Αναλωσίμου - mm	Medidas utilizáveis mm Toepasbare afmetingen mm Boy mm
Capacità caricatore n° punti Magazine capacity Magazinkapazität Nägel	Capacité chargeur n° de points Capacidad cargador n° puntos Δωανατοτητα γεμιστερα	Capacidade carregador n° pontos Capaciteit magazijn in aantal spijkers Dergi kapasitesi
Pressione d'esercizio Operating pressure Betriebsdruck	Pression d'exercice Presión de servicio Πίεση λειτουργίας	Pressão de serviço Werkdruk Çalışma basıncı
Consumo aria litri/colpo Air consumption litres/stroke Luftverbrauch Liter/Schuss	Consommation d'air litres/coup Consumo aire litros/golpe Κατανάλωση αέρα - λίτρα/βολή	Consumo ar litros/disparo Luchtverbruik liter/slag Litre/vuruş hava tüketimi
Peso kg Weight kg Gewicht kg	Poids kg Peso kg Βάρος - kg	Peso kg Gewicht in kg Ağırlık kg
Dimensioni mm Dimensions mm Abmessungen mm	Dimensions mm Dimensiones mm Διαστάσεις mm	Dimensões mm Afmetingen mm Boyutlar mm
UNI EN 12549 :2009	UNI EN ISO 3746 :2011	UNI EN ISO 4871 :2009
Potenza sonora emessa Sound power emitted Emittierte Schalleistung	Puissance sonore émise Potencia sonora emitida Εκπεμπόμενη ηχητική ισχύς	Potência sonora emitida Geëmitteerd geluidsvermogen Çıkan ses gücü (ses desibeli)

Tipo di punto
Type of fastener
Befestigungsmittel
Type de rivet
Tipo de punto
Τύπος αναλωσίμου
Tipo de agrafó
Type nietjes
Zimba ve çivi tipleri

3G

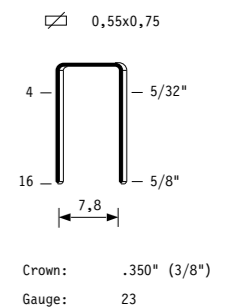

**DO NOT
HANDHELD
THIS TOOL**



11543540-3_3G16CLT3_5_rev20_29/09/2020 IV

Parti di ricambio - Spare parts - Ersatzteile - Pièces de rechange - Recambios
Ανταλλακτικά - Partes sobresselentes - Wisselstukken - Yedek parçalar

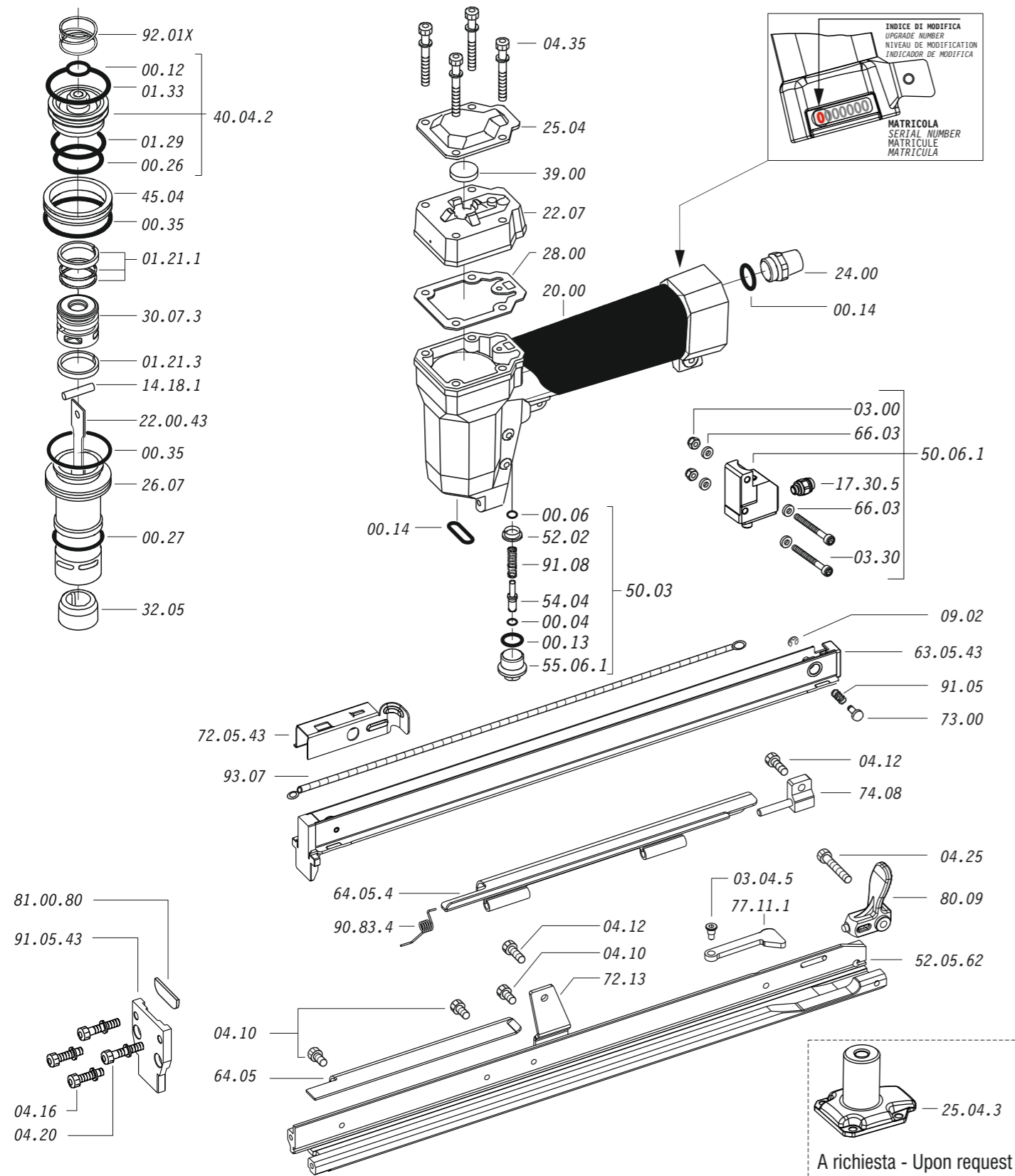

Dotazioni - Equipment - Ausstattung - Outillage - Dotaciones - Εξοπλισμός
Dotações - Uitrusting - Donanımlar

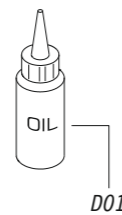

3G.16 CLT-3

cod. 11543540-3

Parti di ricambio - Spare parts - Ersatzteile - Pièces de rechange - Recambios
Ανταλλακτικά - Partes sobresselentes - Wisselstukken - Yedek parçalar

Cod.	Descrizione	Description
00.04	O-Ring	O-Ring
00.06	O-Ring	O-Ring
00.12	O-Ring	O-Ring
00.13	O-Ring	O-Ring
00.14	O-Ring	O-Ring
00.26	O-Ring	O-Ring
00.27	O-Ring	O-Ring
00.35	O-Ring	O-Ring
01.21.1	Guarnizione	Gasket
01.21.3	Guarnizione	Gasket
01.29	O-Ring	O-Ring
01.33	O-Ring	O-Ring
03.00	Dado	Nut
03.04.5	Vite	Screw
03.30	Vite	Screw
04.10	Vite	Screw
04.12	Vite	Screw
04.16	Vite	Screw
04.20	Vite	Screw
04.25	Vite	Screw
04.35	Vite	Screw
07.30	Chiave esagonale	Hex. bar wrench
09.02	Anello elastico	Elastic ring
14.18.1	Spina	Pin
17.30.5	Attacco	Connection
20.00	Corpo	Body
22.07	Testa	Head
24.00	Silenziatore	Silencer
25.04	Deflettore	Exhaust deflector
25.04.3	Deflettore	Exhaust deflector
26.07	Cilindro	Cylinder
28.00	Guarnizione	Gasket
30.07.3	Pistone	Piston
32.05	Ammortizzatore	Bumper
39.00	Guarnizione scarico	Exhaust gasket
40.04.2	Valvola completa	Valve ass'y
45.04	Anello valvola	Ring
50.03	Pulsante completo	Trigger valve ass'y
50.06.1	Comando a distanza	Remote control trigger
52.02	Boccola	Bush
54.04	Pulsante	Trigger valve
55.06.1	Raccordo	Bush
64.05	Carter	Hold down
64.05.4	Carter mobile	Hold down
66.03	Rondella	Washer
77.11.1	Leva	Lever
72.13	Reggicaricatore	Support
73.00	Perno	Pin
74.08	Staffa	Support
80.09	Grilletto chiusura	Trigger
91.05	Molla	Spring
91.08	Molla	Spring
90.83.4	Molla	Spring
92.01X	Molla	Spring
93.07	Molla	Spring
22.00.43	Battente	Driver
52.05.62	Caricatore	Magazine
63.05.43	Carrello	Slider
72.05.43	Spingipunto	Pusher
81.00.80	Controtestina	Nose
91.05.43	Testina	Nose plate
D01	Boccetta olio	Oiler

Guarnizioni - O-Rings - Dichtungen - Juntas - Δακτύλιος στεγανοποίησης - Vedantes - O-ringen - Contalar

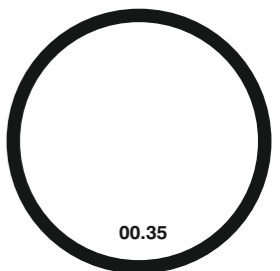
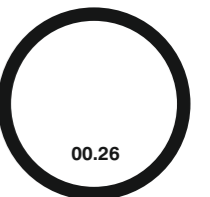
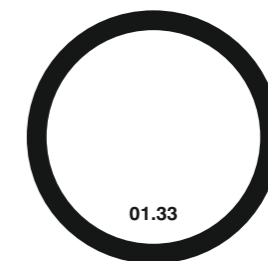
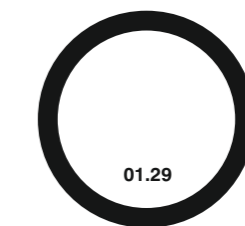
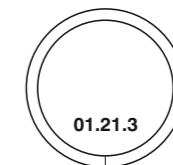
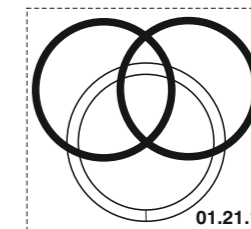
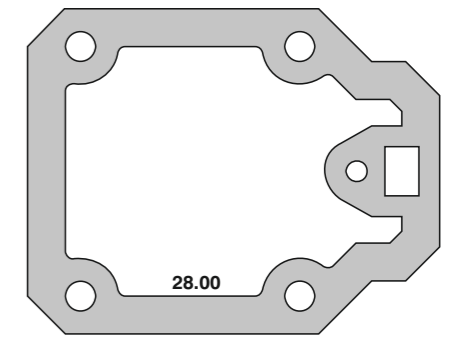

00.70.5

3G.16 CLT-3

cod. 11543540-3

Indice di modifica
Upgrade number

5