

Collegamento - Connection

Collegamento:
Connection:

Valvola 3/2 NC
Valve 3/2 NC

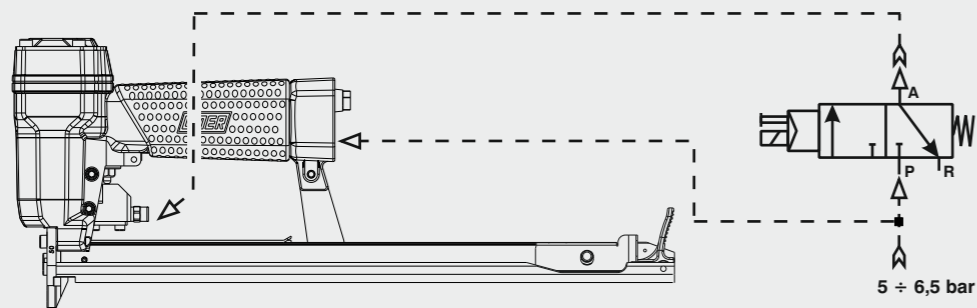

OMER

Manuale d'uso, manutenzione e parti di ricambio
Manual for use, maintenance and spare parts
Bedienungs- und Wartungshandbuch sowie Ersatzteilleiste
Mode d'emploi, de maintenance et pièces de rechange
Manual de uso, mantenimiento y recambios
Εγχειρίδιο χρήσης, συντήρησης και ανταλλακτικών
Manual de uso, manutenção e peças sobresselentes
Handleiding voor gebruik, onderhoud en wisselstukken
Kullanım, bakım ve yedek parça kılavuzu
Användar-, underhålls- och reservdelshandbok

Parte 2
Part 2
Teil 2
Partie 2
Part 2
Μέρος 2
Parte 2
Deel 2
Kısım 2
Del 2



Caricamento - Loading - Laden - Chargement - Carga - Γέμισμα - Carregamento - Laden - Yükleme - Laddning

Caricamento da sopra
Top load magazine

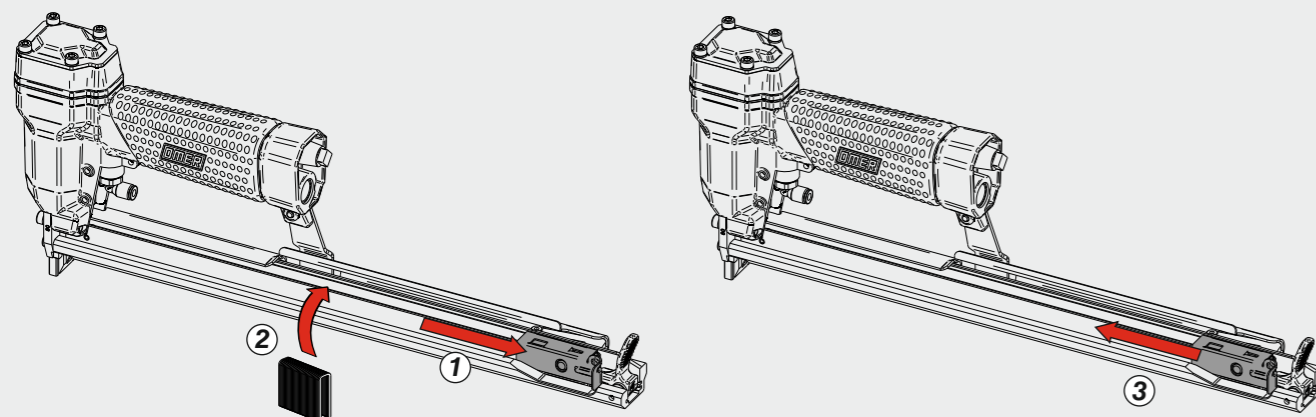

64.16 CLT-3

cod. 11554540-3

Disincerramento - Jam clearing - Staubeseitigung - Décoincement - Desatascamiento - Απεμπλοκή
Desencravamento - Deblokkering bij vastlopen - Sıkışma giderme - Rensning av igensättningar

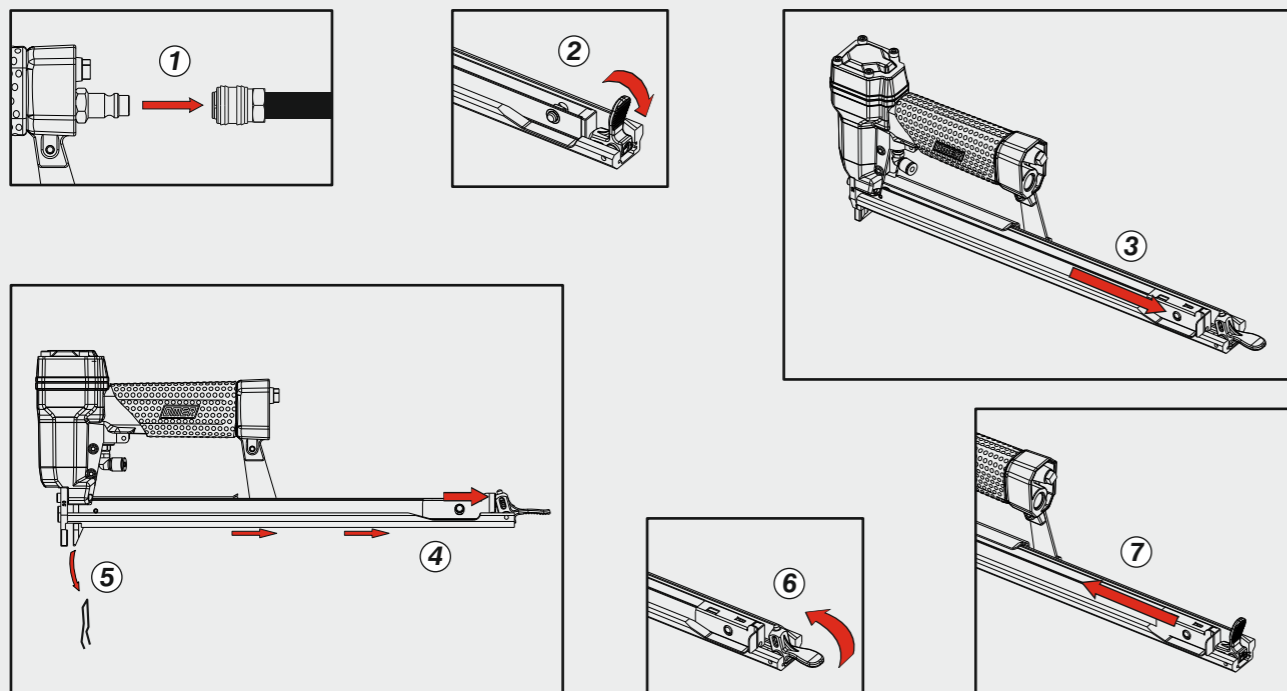

Dati tecnici

Technical data
Technische Daten
Tekniska data

Caractéristiques techniques
Datos técnicos
Τεχνικά χαρακτηριστικά

Dados técnicos
Technische gegevens
Teknik veriler

Misure impiegabili
Lengths
Verwendbare Nagellänge
Dimensioner som kan användas

Dimensions utiles
Medidas de longitud
Μήκος Αναλωσίμου

Medidas utilizáveis
Toepasbare afmetingen
Boy

mm
inch
4 ÷ 16
5/32" ÷ 5/8"

Capacità caricatore n° punti
Magazine capacity
Magazinkapazität Nägel
Magasinkapacitet Antal punkter

Capacité chargeur n° de points
Capacidad cargador n° puntos
Δυνατότητα γεμιστέρα

Capacidade carregador n° pontos
Capaciteit magazijn in aantal spijkers
Dergi kapasitesi

360

Pressione d'esercizio
Operating pressure
Betriebsdruck
Drifttryck

Pression d'exercice
Presión de servicio
Πίεση λειτουργίας

Pressão de serviço
Werkdruk
Çalışma basıncı

bar
psi
4 ÷ 6
60 ÷ 90

Consumo aria
Air consumption
Luftverbrauch
Luftförbrukning

Consommation d'air
Consumo aire
Κατανάλωση αέρα

Consumo ar
Luchtverbruik
Hava tüketimi

lt/colpo
ft³/cycle
0,13
0,00459

Peso
Weight
Gewicht
Vikt

Poids
Peso
Βάρος

Peso
Gewicht
Ağırlık

kg
lbs
1,17
2,57

Dimensioni
Dimensions
Abmessungen
Dimensioner (AxBxH)

Dimensions
Dimensiones
Διαστάσεις

Dimensões
Afmetingen
Boyutlar

mm
inch
378x43x148
14-7/8"x1-11/16"x5-7/8"
(LxWxH)

EN 12549 :2009 EN ISO 3746 :2011 EN ISO 4871 :2009

Potenza sonora emessa
Sound power emitted
Emittierte Schalleistung
Avgiven ljudeffekt

Puissance sonore émise
Potencia sonora emitida
Εκπεμπόμενη ηχητική ισχύς

Potência sonora emitida
Geëmitteerd geluidsvermogen
Çıkan ses gücü (ses desibeli)

dB(A)
87

(K = 4 dB)

Tipo di punto
Type of fastener
Befestigungsmittel
Type de rivet
Tipo de punto
Τύπος αναλωσίμου
Tipo de agrafa
Type nietjes
Zimba ve çivi tipleri
Typ av stygn

64

0,55x0,75

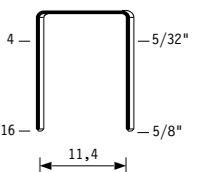

Crown: .488" (1/2")
Gauge: 23

11554540-3_6416CLT-3_5_rev21_28/11/2023 DV

DO NOT
HANDHELD
THIS TOOL



Parti di ricambio - Spare parts - Ersatzteile - Pièces de rechange - Recambios
Ανταλλακτικά - Partes sobresselentes - Wisselstukken - Yedek parçalar

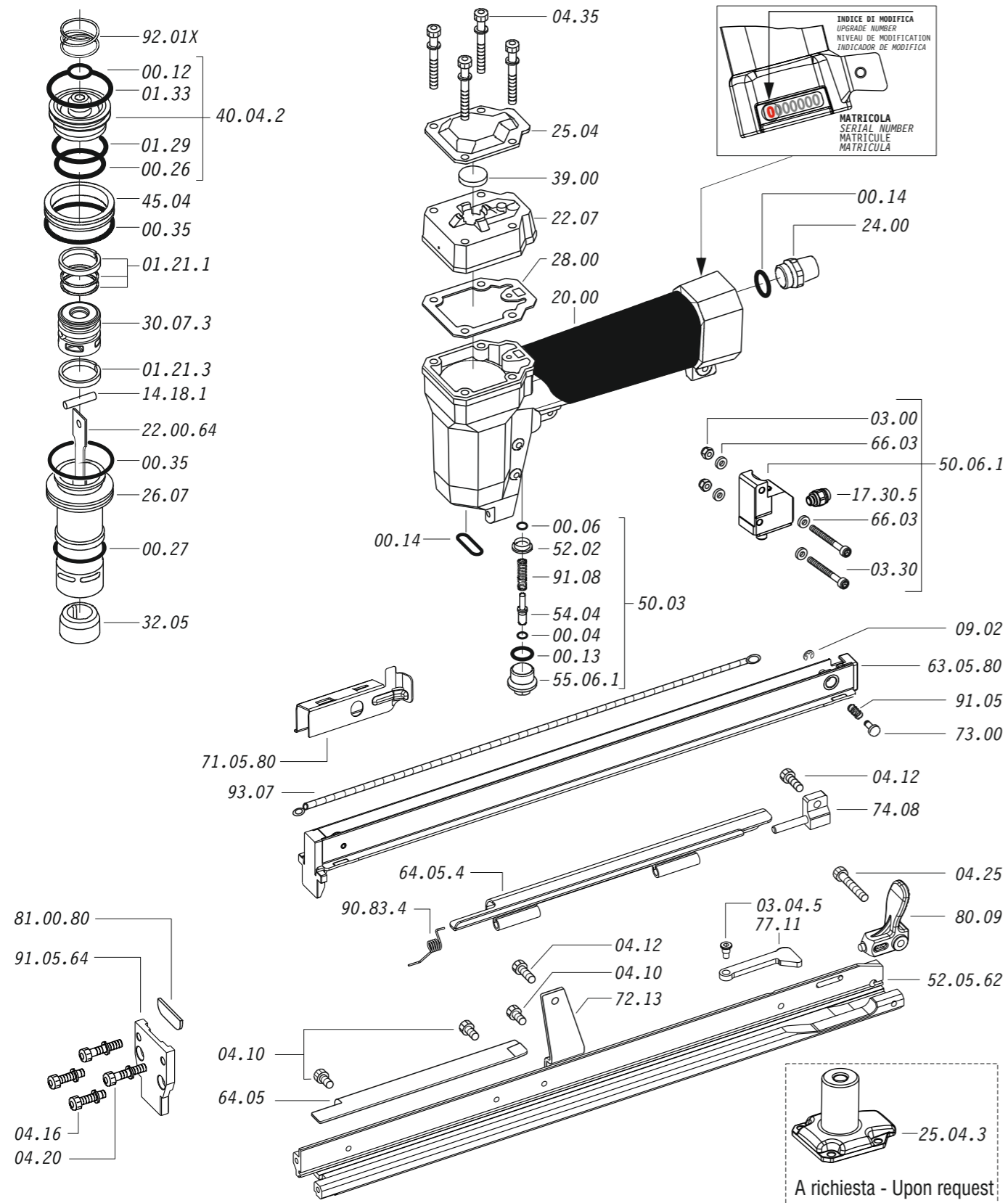

Dotazioni - Equipment - Ausstattung - Outillage - Dotaciones - Εξοπλισμός
Dotações - Uitrusting - Donanımlar

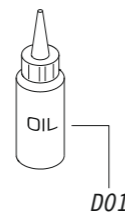

64.16 CLT-3

cod. 11554540-3

Parti di ricambio - Spare parts - Ersatzteile - Pièces de rechange - Recambios
Ανταλλακτικά - Partes sobresselentes - Wisselstukken - Yedek parçalar

Cod.	Descrizione	Description
00.04	O-Ring	O-Ring
00.06	O-Ring	O-Ring
00.12	O-Ring	O-Ring
00.13	O-Ring	O-Ring
00.14	O-Ring	O-Ring
00.26	O-Ring	O-Ring
00.27	O-Ring	O-Ring
00.35	O-Ring	O-Ring
01.21.1	Guarnizione	Gasket
01.21.3	Guarnizione	Gasket
01.29	O-Ring	O-Ring
01.33	O-Ring	O-Ring
03.00	Dado	Nut
03.04.5	Vite	Screw
03.30	Vite	Screw
04.10	Vite	Screw
04.12	Vite	Screw
04.16	Vite	Screw
04.20	Vite	Screw
04.25	Vite	Screw
04.35	Vite	Screw
07.30	Chiave esagonale	Hex. bar wrench
09.02	Anello elastico	Elastic ring
14.18.1	Spina	Pin
17.30.5	Attacco	Connection
20.00	Corpo	Body
22.07	Testa	Head
24.00	Silenziatore	Silencer
25.04.3	Deflettore	Exhaust deflector
25.04	Deflettore	Exhaust deflector
26.07	Cilindro	Cylinder
28.00	Guarnizione	Gasket
30.07.3	Pistone	Piston
32.05	Ammortizzatore	Bumper
39.00	Guarnizione scarico	Exhaust gasket
40.04.2	Valvola completa	Trigger valve ass'y
45.04	Anello valvola	Ring
50.03	Pulsante completo	Valve ass'y
50.06.1	Comando a distanza	Remote control trigger
52.02	Boccola	Bush
54.04	Pulsante	Trigger valve
55.06.1	Raccordo	Bush
64.05	Carter	Hold down
64.05.4	Carter mobile	Hold down
66.03	Rondella	Washer
72.13	Reggicaricatore	Support
73.00	Perno	Pin
74.08	Staffa	Support
77.11	Leva	Lever
80.09	Grilletto chiusura	Trigger
91.05	Molla	Spring
91.08	Molla	Spring
90.83.4	Molla	Spring
92.01X	Molla	Spring
93.07	Molla	Spring
22.00.64	Battente	Driver
52.05.62	Caricatore	Magazine
63.05.80	Carrello	Slider
71.05.80	Spingipunto	Pusher
81.00.80	Controtestina	Nose
91.05.64	Testina	Nose plate
D01	Bocchetta olio	Oiler

Guarnizioni - O-Rings - Dichtungen - Juntas - Δακτύλιος στεγανοποίησης - Vedantes - O-ringen - Contalar

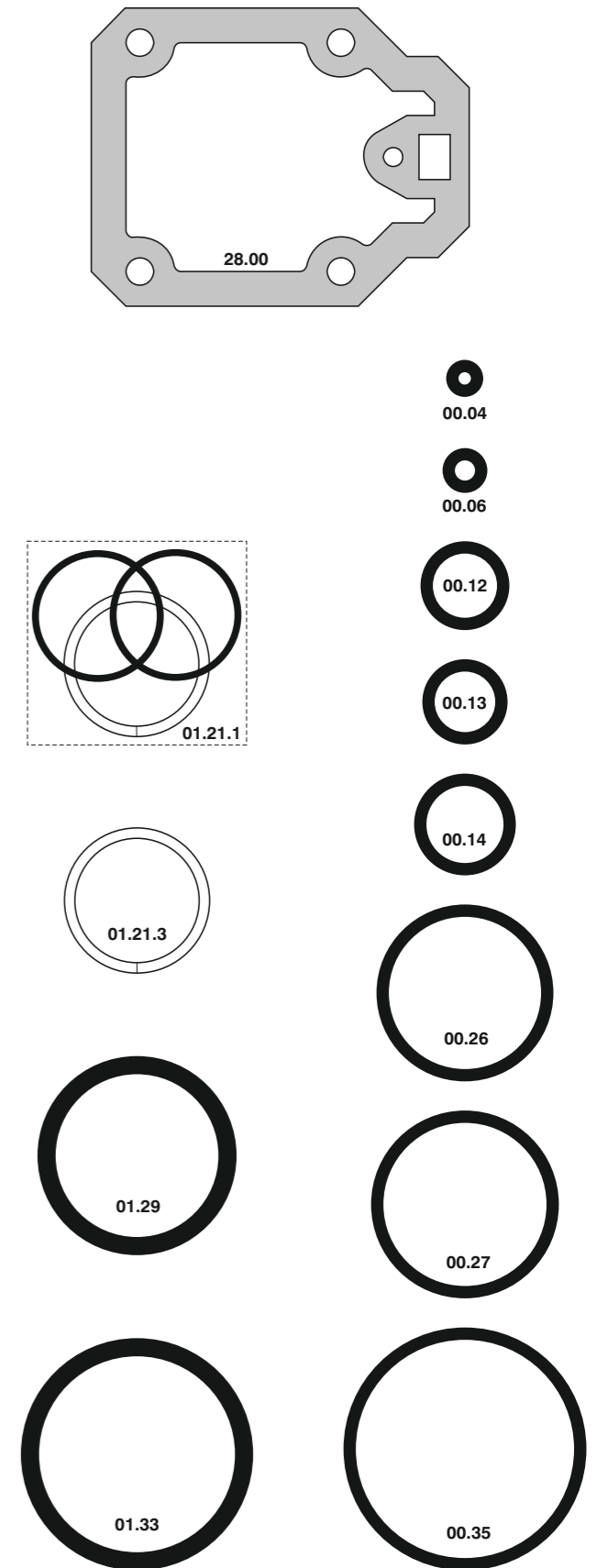

00.70.5

Indice di modifica
Upgrade number

5

64.16 CLT-3

cod. 11554540-3