

Azionamento continuo con doppia attivazione

Continual actuation with dual activation

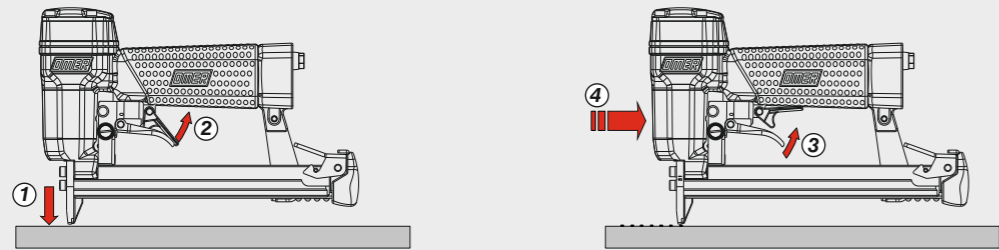

Azionamento singolo con doppia attivazione

Single actuation with dual activation

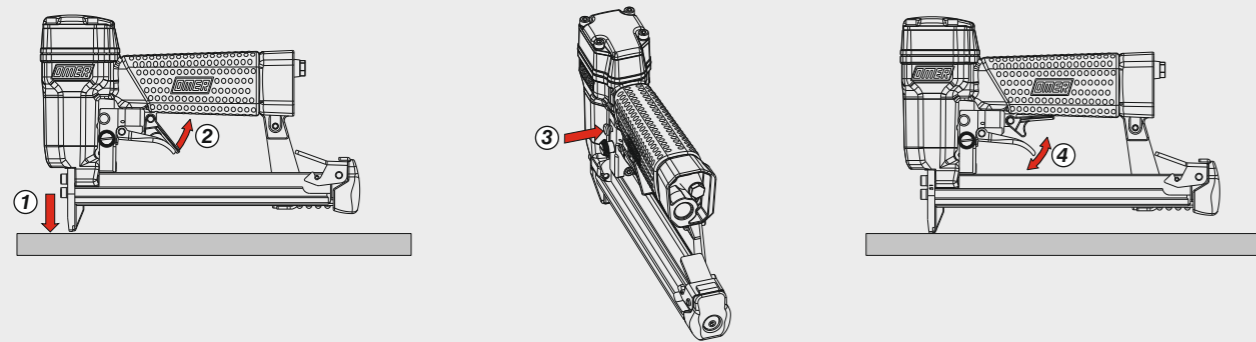

Caricamento - Loading - Laden - Chargement - Carga - Γέμισμα - Carregamento - Laden - Yükleme

Caricamento da sotto

Bottom load magazine

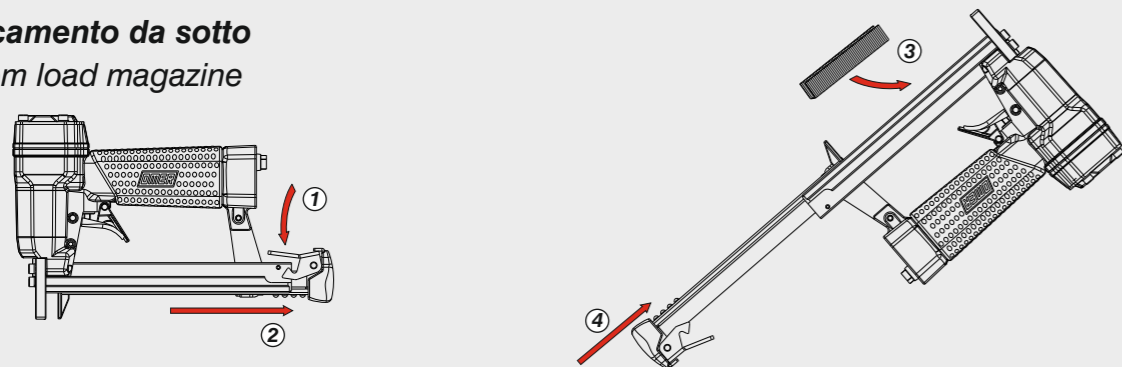

Disinseppamento - Jam clearing - Staubeseitigung

Décoincement - Desatascamiento

Απεμπλοκή - Desencravamento

Deblokkering bij vastlopen - Sıkışma giderme

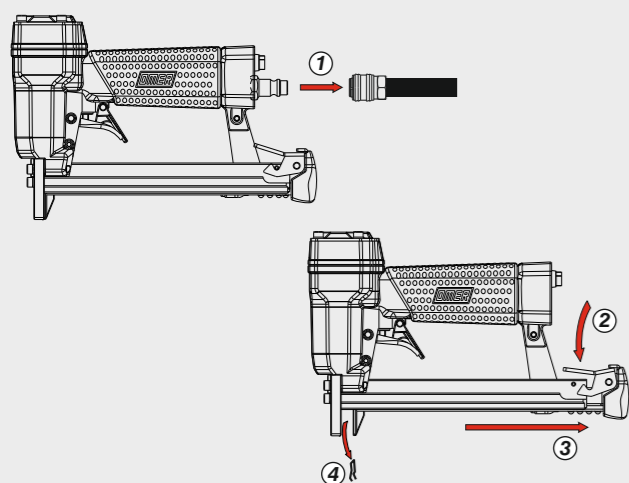

Regolazioni - Adjustments

Regolazione della velocità

Speed adjustment

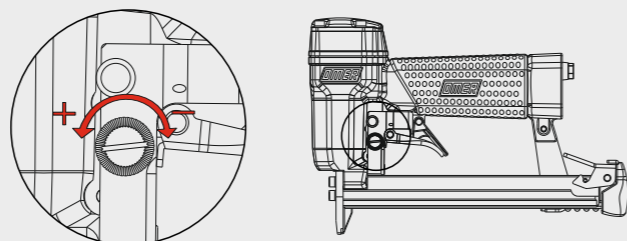

Max 1800 rpm



Manuale d'uso, manutenzione e parti di ricambio
Manual for use, maintenance and spare parts
Bedienungs- und Wartungshandbuch sowie Ersatzteilleiste
Mode d'emploi, de maintenance et pièces de rechange
Manual de uso, mantenimiento y recambios
Εγχειρίδιο χρήσης, συντήρησης και ανταλλακτικών
Manual de uso, manutenção e peças sobresselentes
Handleiding voor gebruik, onderhoud en wisselstukken
Kullanım, bakım ve yedek parça kılavuzu

Parte 2
Part 2
Teil 2
Partie 2
Part 2
Μέρος 2
Parte 2
Deel 2
Kısım 2



64.16 CLV

cod. 11554580

Dati tecnici Technical data Technische Daten	Caractéristiques techniques Datos técnicos Τεχνικά χαρακτηριστικά	Dados técnicos Technische gegevens
Misure impiegabili mm Lengths mm Verwendbare Nagellänge mm	Dimensions utiles mm Medidas de longitud mm Μήκος Αναλωσίμου - mm	Medidas utilizáveis mm Toepasbare afmetingen mm Boy mm
Capacità caricatore n° punti Magazine capacity Magazinkapazität Nägel	Capacité chargeur n° de points Capacidad cargador n° puntos Δωνωτοτητα γεμιστερα	Capacidade carregador n° pontos Capaciteit magazijn in aantal spijkers Dergi kapasitesi
Pressione d'esercizio Operating pressure Betriebsdruck	Pression d'exercice Presión de servicio Πίεση λειτουργίας	Pressão de serviço Werkdruk Çalışma basıncı
Consumo aria litri/colpo Air consumption litres/stroke Luftverbrauch Liter/Schuss	Consommation d'air litres/coup Consumo aire litros/golpe Κατανάλωση αέρα - λίτρα/βολή	Consumo ar litros/disparo Luchtverbruik liter/slag Litre/vuruş hava tüketimi
Peso kg Weight kg Gewicht kg	Poids kg Peso kg Βάρος - kg	Peso kg Gewicht in kg Ağırlık kg
Dimensioni mm Dimensions mm Abmessungen mm	Dimensions mm Dimensiones mm Διαστάσεις mm	Dimensões mm Afmetingen mm Boyutlar mm
UNI EN 12549 :2009	UNI EN ISO 4871 :2009	
Pressione sonora in pos. operatore Sound pressure in operator's position Schalldruck am Arbeitsplatz	Pression sonore poste Opérateur Presión sonora en la pos. del operador Ηχητική πίεση στη θέση του Χειριστή	Pressão sonora na posição Operador Geluidsdruk op de werkplaats Operatör pozisyonunda ses basıncı
		83 dB(A) (K= 4 dB)
UNI EN 12549 :2009	UNI EN ISO 3746 :2011	UNI EN ISO 4871 :2009
Potenza sonora emessa Sound power emitted Emittierte Schalleistung	Puissance sonore émise Potencia sonora emitida Εκπεμπόμενη ηχητική ισχύς	Potência sonora emitida Geëmitteerd geluidsvermogen Çıkan ses gücü (ses desibel)
		90 dB(A) (K= 4 dB)
UNI CEN ISO/TS 8662-11 :2006	UNI EN ISO 5349-2 :2004	UNI EN 12096 :1999
Emissione vibratoria sull'impugnatura Vibratory emissions on handle Vibrationsemission am Griff	Émission vibratoire sur la prise en main Emisión de vibraciones en la empuñadura Εκπεμπόμενες δονήσεις στη λαβή	Emissão vibratória na empunhadura Trillingsemissie op de handgreep Tutamak üzerinde vibrasyon emisyonları
		2,60 m/s² (K= 2 m/s ²)

Tipo di punto
Type of fastener
Befestigungsmittel
Type de rivet
Tipo de punto
Τύπος αναλωσίμου
Tipo de agrafa
Type nietjes
Zimba ve çivi tipleri

64

0,55x0,75

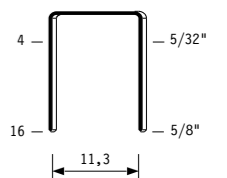

Crown: .488" (1/2")
Gauge: 23

Parti di ricambio - Spare parts - Ersatzteile - Pièces de rechange - Recambios
Ανταλλακτικά - Partes sobresselentes - Wisselstukken - Yedek parçalar

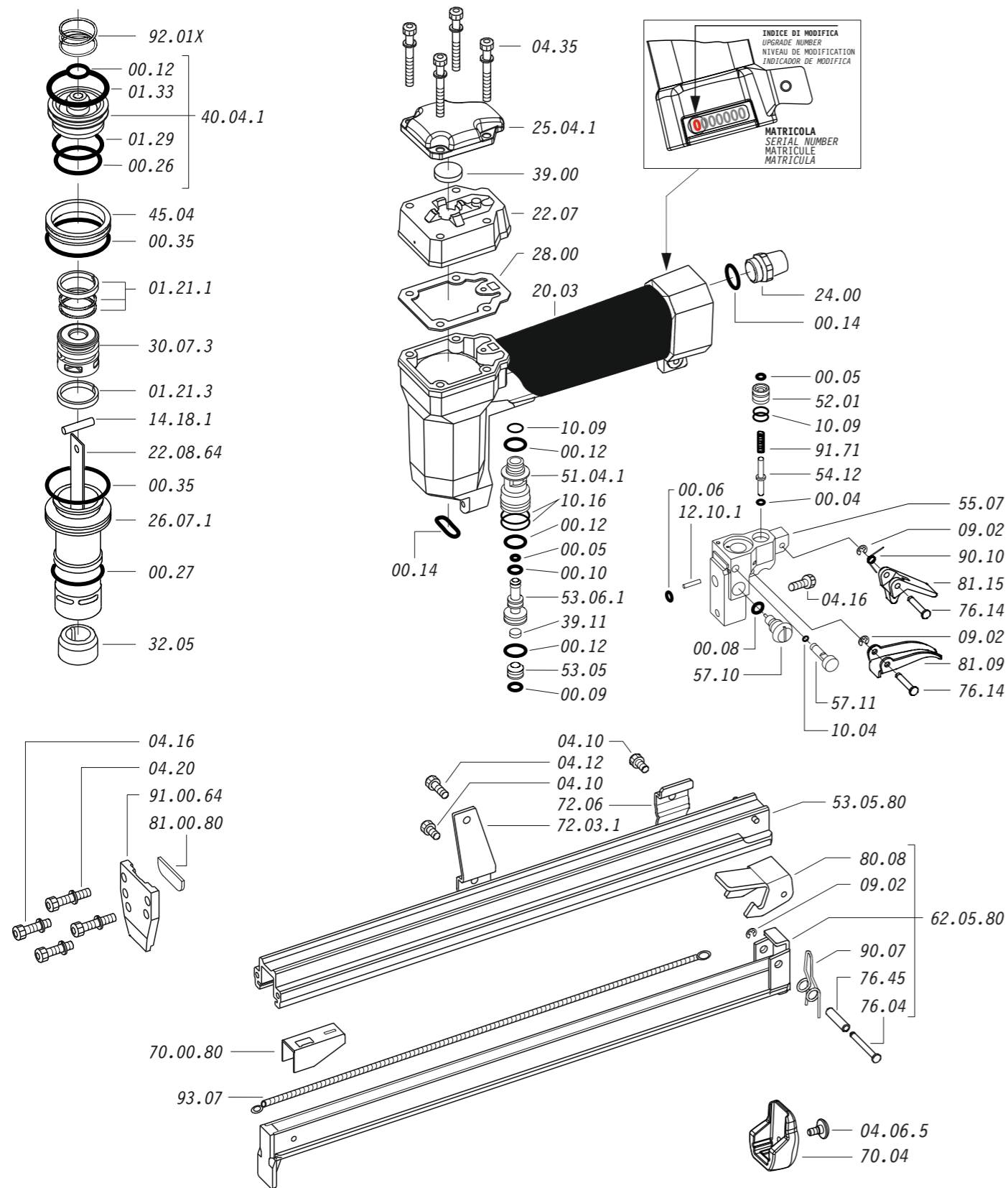

Dotazioni - Equipment - Ausstattung - Outillage - Dotaciones - Εξοπλισμός
Dotações - Uitrusting - Donanımlar

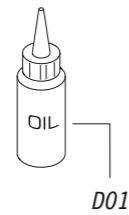

64.16 CLV

cod. 11554580

Parti di ricambio - Spare parts - Ersatzteile - Pièces de rechange - Recambios
Ανταλλακτικά - Partes sobresselentes - Wisselstukken - Yedek parçalar

Cod.	Descrizione	Description
00.04	O-Ring	O-Ring
00.05	O-Ring	O-Ring
00.06	O-Ring	O-Ring
00.08	O-Ring	O-Ring
00.09	O-Ring	O-Ring
00.10	O-Ring	O-Ring
00.12	O-Ring	O-Ring
00.14	O-Ring	O-Ring
00.26	O-Ring	O-Ring
00.27	O-Ring	O-Ring
00.35	O-Ring	O-Ring
01.21.1	Guarnizione	Gasket
01.21.3	Guarnizione	Gasket
01.29	O-Ring	O-Ring
01.33	O-Ring	O-Ring
04.06.5	Vite	Screw
04.10	Vite	Screw
04.12	Vite	Screw
04.16	Vite	Screw
04.20	Vite	Screw
04.35	Vite	Screw
07.30	Chiave esagonale	Hex. bar wrench
09.02	Anello elastico	Elastic ring
10.04	O-Ring	O-Ring
10.09	O-Ring	O-Ring
10.16	O-Ring	O-Ring
12.10.1	Spina	Pin
14.18.1	Spina	Pin
20.03	Corpo	Body
22.07	Testa	Head
24.00	Silenziatore	Silencer
25.04.1	Deflettore	Exhaust deflector
26.07.1	Cilindro	Cylinder
28.00	Guarnizione	Gasket
30.07.3	Pistone	Piston
32.05	Ammortizzatore	Bumper
39.00	Guarnizione scarico	Exhaust gasket
39.11	Guarnizione servovalvola	Valve gasket
40.04.1	Valvola completa	Valve ass'y
45.04	Anello valvola	Ring
51.04.1	Cilindro servovalvola	Valve cylinder
52.01	Boccola pulsante	Tiger valve bush
53.05	Pistoncino	Piston
53.06.1	Pistone servovalvola	Valve piston
54.12	Pulsante	Trigger valve
55.07	Corpo servovalvola	Valve body
57.10	Regolatore	Regulator
57.11	Interruttore	Switch
70.04	Protezione	Guard
72.03.1	Reggicaricatore	Support
72.06	Fermo carrello	Slider-stop
76.04	Perno	Pin
76.14	Perno	Pin
76.45	Perno molla	Pin
80.08	Grilletto chiusura	Trigger
81.09	Grilletto comando	Trigger
81.15	Controgrilletto	Trigger
90.07	Molla	Spring
90.10	Molla	Spring
91.71	Molla	Spring
92.01X	Molla	Spring
93.07	Molla	Spring
22.08.64	Battente	Driver
53.05.80	Caricatore	Magazine
62.05.80	Carrello	Slider
70.00.80	Spingipunto	Pusher
81.00.80	Controtestina	Nose
91.00.64	Testina	Nose plate
D01	Bocchetta olio	Oiler

Guarnizioni - O-Rings - Dichtungen - Juntas - Δακτύλιος στεγανοποίησης - Vedantes - O-ringen - Contalar

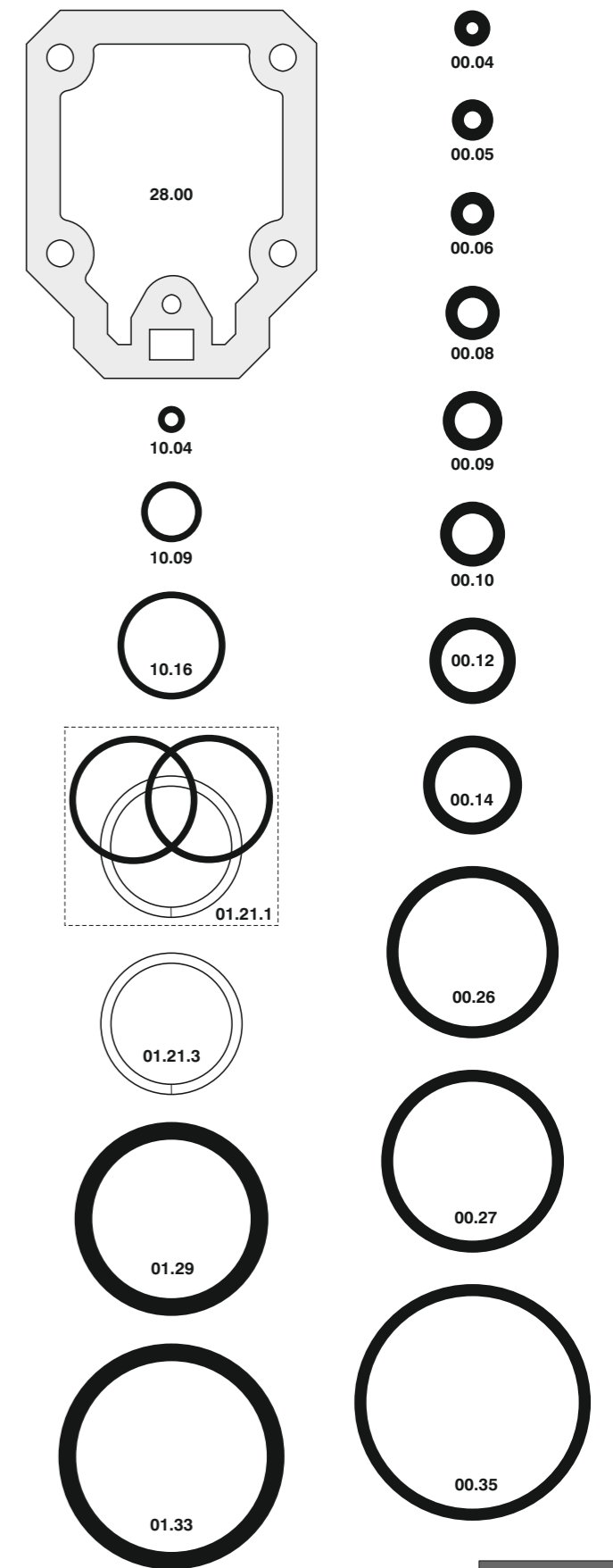

64.16 CLV

cod. 11554580

Indice di modifica
Upgrade number

6