

Caricamento da sotto
Bottom load magazine

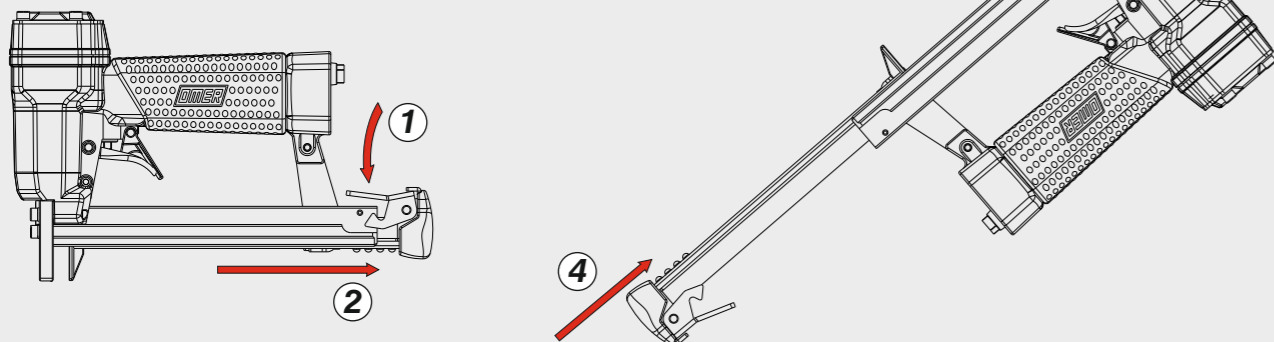

Caricamento dischi - Disk loading

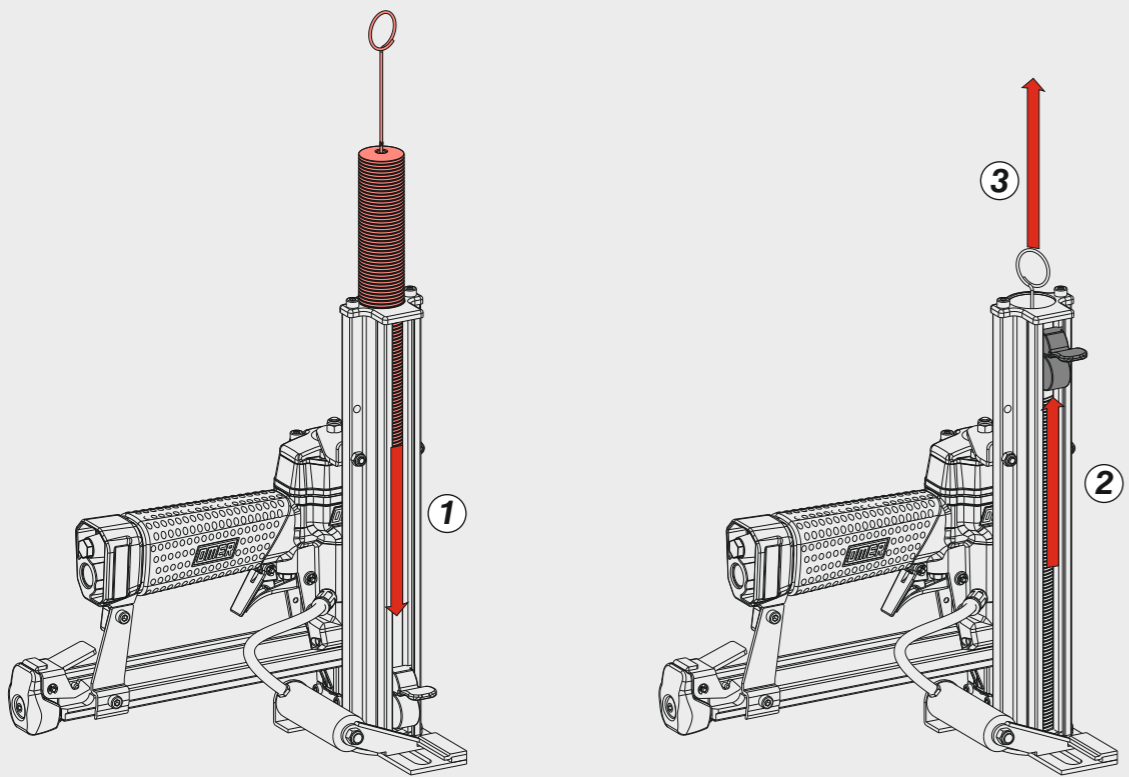

Disincerramento - Jam clearing - Staubeseitigung - Décoincement - Desatascamiento - Απεμπλοκή
Desencravamento - Deblokkering bij vastlopen - Sıkışma giderme

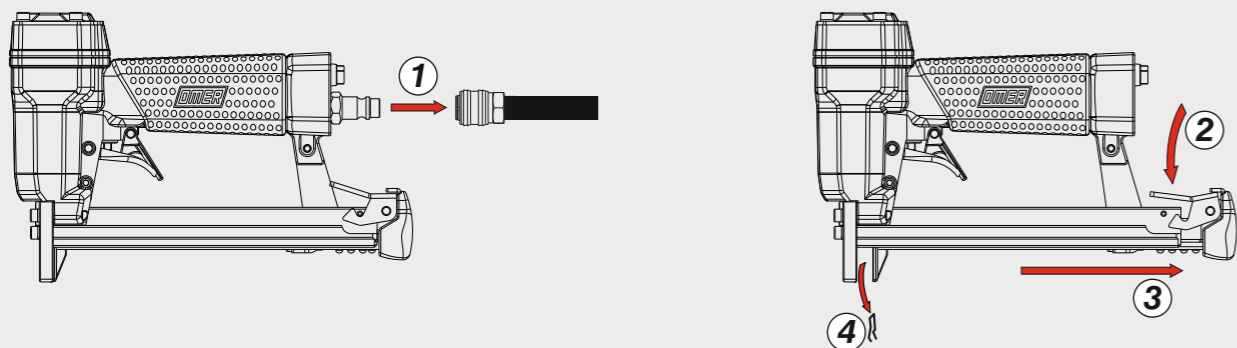

Manuale d'uso, manutenzione e parti di ricambio **Parte 2**
Manual for use, maintenance and spare parts **Part 2**
Bedienungs- und Wartungshandbuch sowie Ersatzteilleiste **Teil 2**
Mode d'emploi, de maintenance et pièces de rechange **Partie 2**
Manual de uso, mantenimiento y recambios **Part 2**
Εγχειρίδιο χρήσης, συντήρησης και ανταλλακτικών **Μέρος 2**
Manual de uso, manutenção e peças sobresselentes **Parte 2**
Handleiding voor gebruik, onderhoud en wisselstukken **Deel 2**
Kullanım, bakım ve yedek parça kılavuzu **Kısım 2**



83P DK

cod. 1156390DK



Dati tecnici Technical data Technische Daten	Caractéristiques techniques Datos técnicos Τεχνικά χαρακτηριστικά	Dados técnicos Technische gegevens Teknik veriler
Misure impiegabili mm Lengths mm Verwendbare Nagellänge mm	Dimensions utiles mm Medidas de longitud mm Μήκος Αναλωσίμου - mm	Medidas utilizáveis mm Toepasbare afmetingen mm Boy mm
Capacità caricatore n° punti Magazine capacity Magazinkapazität Nägel	Capacité chargeur n° de points Capacidad cargador n° puntos Δωσατοτητα γεμιστερα	Capacidade carregador n° pontos Capaciteit magazijn in aantal spijkers Dergi kapasitesi
Pressione d'esercizio Operating pressure Betriebsdruck	Pression d'exercice Presión de servicio Πίεση λειτουργίας	Pressão de serviço Werkdruk Çalışma basıncı
Consumo aria litri/colpo Air consumption litres/stroke Luftverbrauch Liter/Schuss	Consommation d'air litres/coup Consumo aire litros/golpe Κατανάλωση αέρα - λίτρα/βολή	Consumo ar litros/disparo Luchtverbruik liter/slag Litre/vuruş hava tüketimi
Peso kg Weight kg Gewicht kg	Poids kg Peso kg Βάρος - kg	Peso kg Gewicht in kg Ağırlık kg
Dimensioni mm Dimensions mm Abmessungen mm	Dimensions mm Dimensiones mm Διαστάσεις mm	Dimensões mm Afmetingen mm Boyutlar mm
UNI EN 12549 :2009 UNI EN ISO 4871 :2009	Pressione sonora in pos. operatore Sound pressure in operator's position Schalldruck am Arbeitsplatz	Pressão sonora na posição Operador Geluidsdruk op de werkplaats Operatör pozisyonunda ses basıncı
UNI EN 12549 :2009 UNI EN ISO 3746 :2011 UNI EN ISO 4871 :2009	Potenza sonora emessa Sound power emitted Emittierte Schallleistung	Potência sonora emitida Geëmitteerd geluidsvermogen Çıkan ses gücü (ses desibel)
UNI CEN ISO/TS 8662-11 :2006 UNI EN ISO 5349-2 :2004 UNI EN 12096 :1999	Emissione vibratoria sull'impugnatura Vibratory emissions on handle Vibrationsemission am Griff	Emissão vibratória na empunhadura Trillingsemissie op de handgreep Tutamak üzerinde vibrasyon emisyonları

Tipo di punto
Type of fastener
Befestigungsmittel
Type de rivet
Tipo de punto
Τύπος αναλωσίμου
Tipo de agrafó
Type nietjes
Zimba ve çivi tipleri

83P

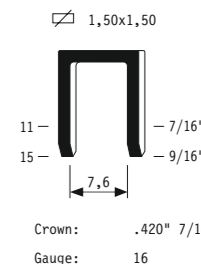

DK25

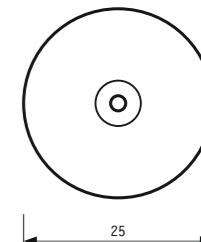

Parti di ricambio - Spare parts - Ersatzteile - Pièces de rechange - Recambios
Ανταλλακτικά - Partes sobresselentes - Wechselstukken - Yedek parçalar

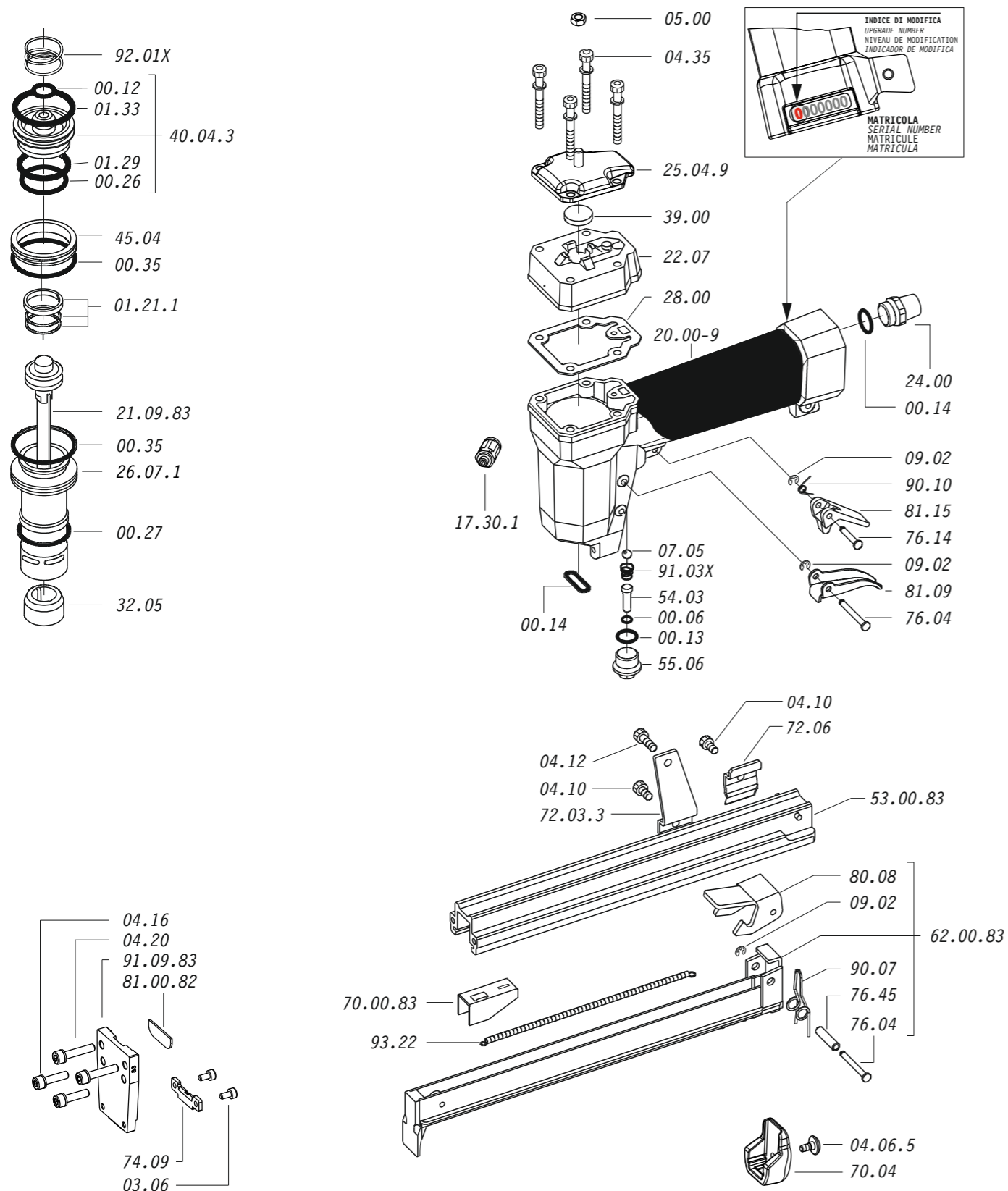

Dotazioni - Equipment - Ausstattung - Outillage - Dotaciones - Εξοπλισμός
Dotações - Uitrusting - Donanımlar

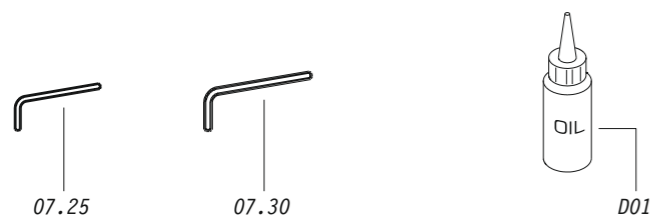

83P DK

cod. 1156390DK

Parti di ricambio - Spare parts - Ersatzteile - Pièces de rechange - Recambios
Ανταλλακτικά - Partes sobresselentes - Wechselstukken - Yedek parçalar

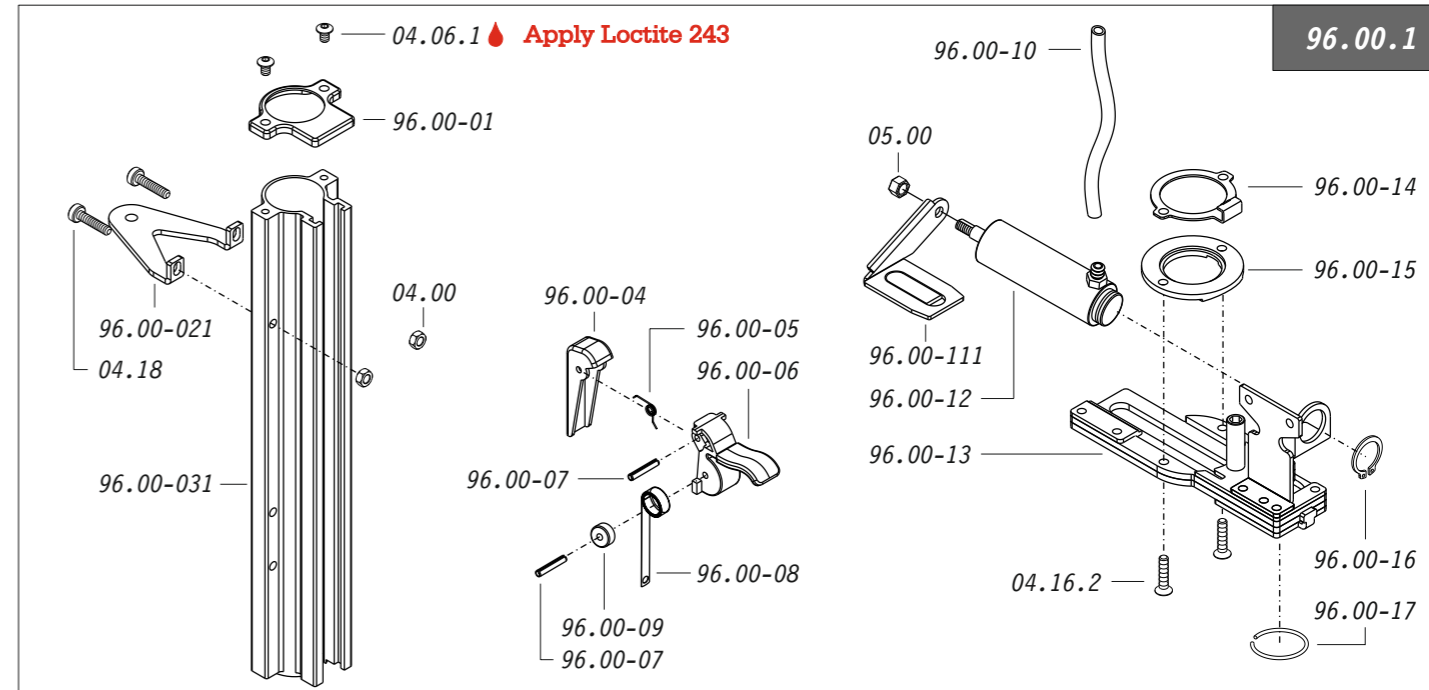

Cod.	Descrizione	Description	Cod.	Descrizione	Description	Cod.	Descrizione	Description
00.06	O-Ring	O-Ring	20.00-9	Corpo	Body	93.22	Molla	Spring
00.12	O-Ring	O-Ring	22.07	Testa	Head	96.00.1	Kit caricatore disc.	Magazine disk Kit
00.13	O-Ring	O-Ring	24.00	Silenziatore	Silencer	96.00-01	Tappo	Cap
00.14	O-Ring	O-Ring	25.04.9	Deflettore	Exhaust deflector	96.00-021	Supporto	Support
00.26	O-Ring	O-Ring	26.07.1	Cilindro	Cylinder	96.00-031	Caricatore dischi	Disk magazine
00.27	O-Ring	O-Ring	28.00	Guarnizione	Gasket	96.00-04	Spingidisco	Pusher
00.35	O-Ring	O-Ring	32.05	Ammortizzatore	Bumper	96.00-05	Molla	Spring
01.21.1	Guarnizione	Gasket	39.00	Guarnizione scarico	Exhaust gasket	96.00-06	Leva	Latch
01.29	O-Ring	O-Ring	40.04.3	Valvola completa	Valve ass'y	96.00-07	Perno	Pin
01.33	O-Ring	O-Ring	45.04	Anello valvola	Ring	96.00-08	Molla	Spring
03.06	Vite	Screw	54.03	Pulsante	Trigger valve	96.00-09	Rullo molla	Roller
04.00	Dado	Nut	55.06	Raccordo	Bush	96.00-10	Tubo	Tube
04.06.1	Vite	Screw	70.02.9K	Supporto bilanciare	Tool hangers	96.00-111	Alimentatore dischi	Disk feeder
04.06.5	Vite	Screw	70.04	Protezione	Guard	96.00-12	Pistone	Piston
04.10	Vite	Screw	72.03.3	Reggicaricatore	Support	96.00-13	Piastra	Plate
04.12	Vite	Screw	72.06	Fermo carrello	Slider stop	96.00-14	Anello	Ring
04.16	Vite	Screw	74.09	Piastrina	Plate	96.00-15	Anello	Ring
04.16.2	Vite	Screw	76.04	Perno	Pin	96.00-16	Anello elastico	Elastic ring
04.18	Vite	Screw	76.14	Perno	Pin	96.00-17	Anello	Ring
04.20	Vite	Screw	76.45	Perno molla	Pin	21.09.83	Battente	Driver
04.35	Vite	Screw	80.08	Grilletto chiusura	Trigger	53.00.83	Caricatore	Magazine
05.00	Dado	Nut	81.09	Grilletto comando	Trigger	62.00.83	Carrello	Slider
07.05	Sfera	Ball	81.15	Controgrilletto	Safety	70.00.83	Spingipunto	Pusher
07.25	Chiave esagonale	Hex. bar wrench	90.07	Molla	Spring	81.00.82	Controtestina	Nose
07.30	Chiave esagonale	Hex. bar wrench	90.10	Molla	Spring	91.09.83	Testina	Nose plate
09.02	Anello elastico	Elastic ring	91.03X	Molla	Spring	D01	Bocchetta olio	Oiler
17.30.1	Attacco	Connection	92.01X	Molla	Spring			

Guarnizioni - O-Rings - Dichtungen - Joints toriques - Juntas
Δακτύλιος στεγανοποίησης - Vedantes - O-ringen - Contalar

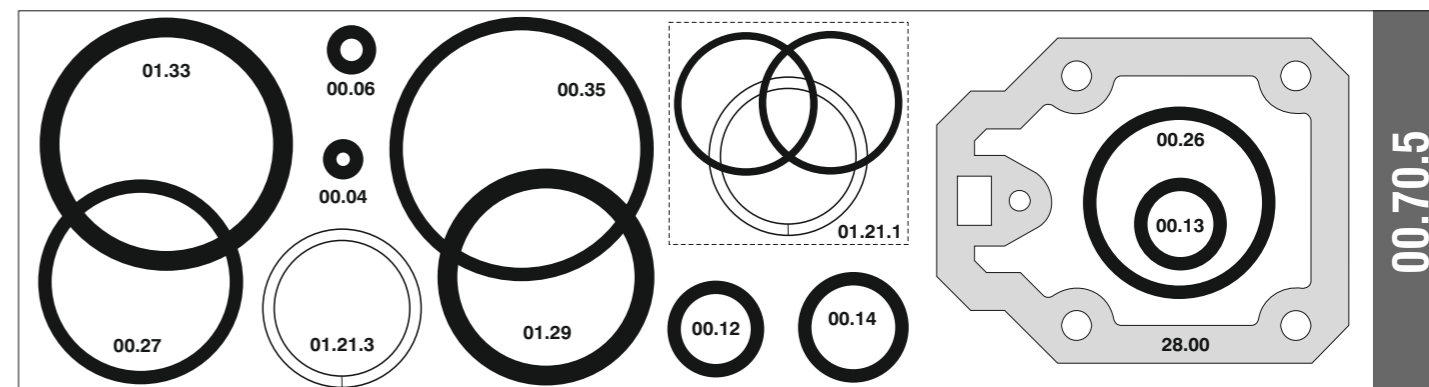

83P DK

cod. 1156390DK

Indice di modifica
Upgrade number

5

Azionamento singolo con doppia attivazione

Single actuation with dual activation

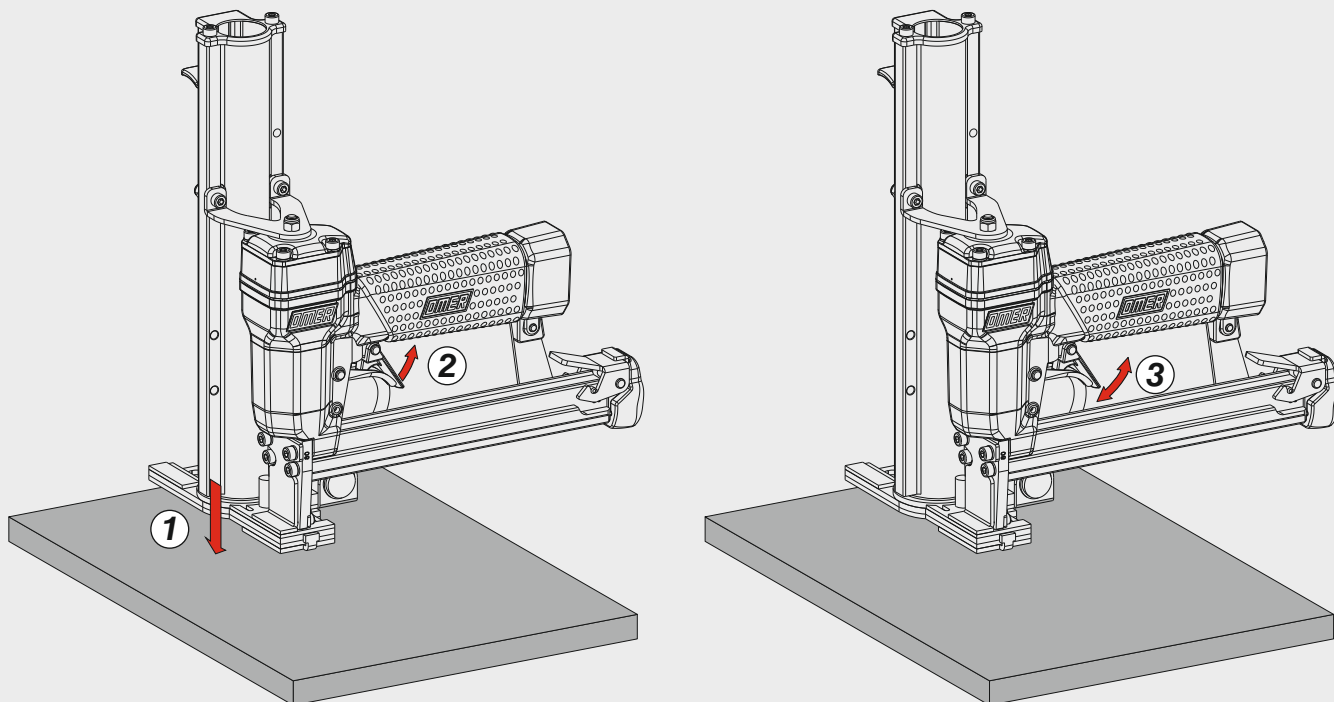

Supporto bilanciante - Tool hangers

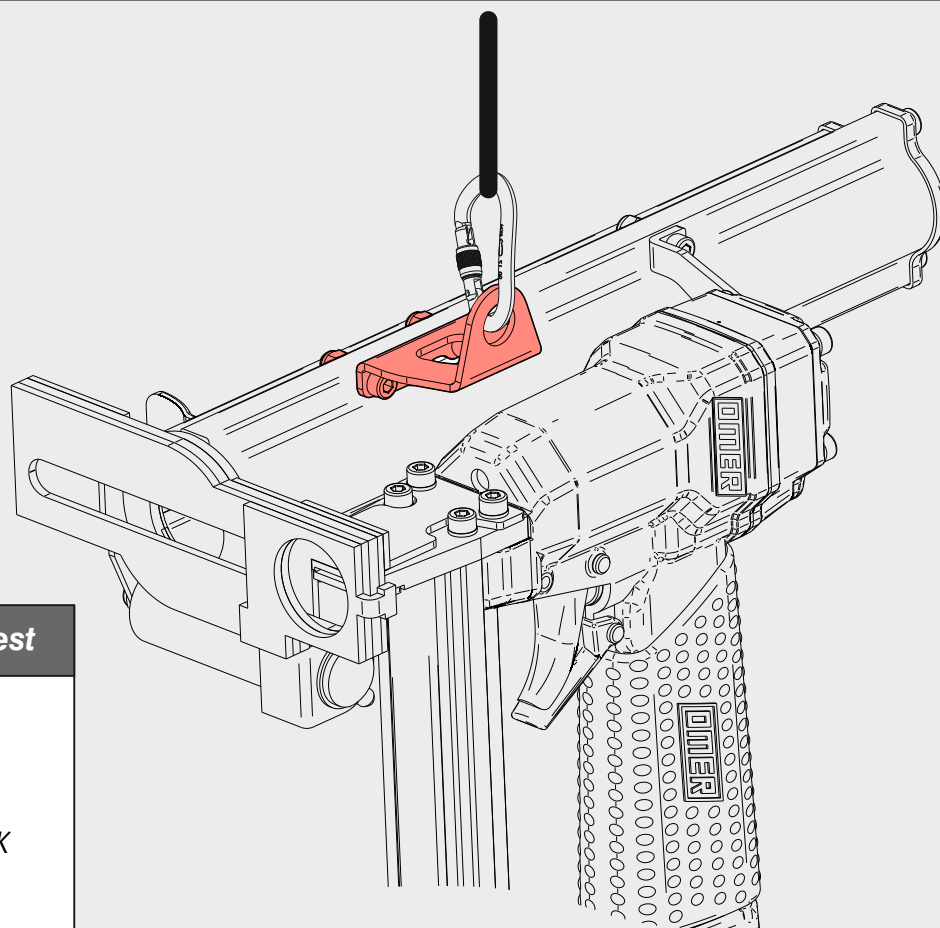

A richiesta - On request

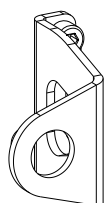

70.02.9K