

Azionamento singolo con doppia attivazione

Single actuation with dual activation

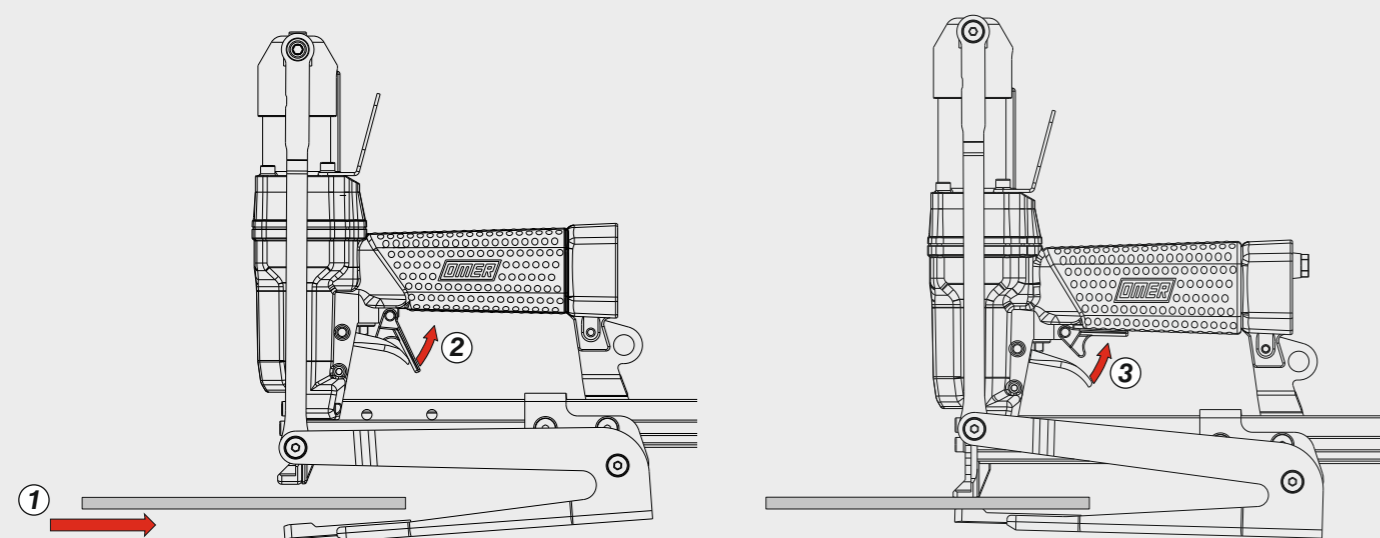

Caricamento - Loading - Laden - Chargement - Carga - Γέμισμα - Carregamento - Laden - Yükleme

Caricamento da sotto

Bottom load magazine

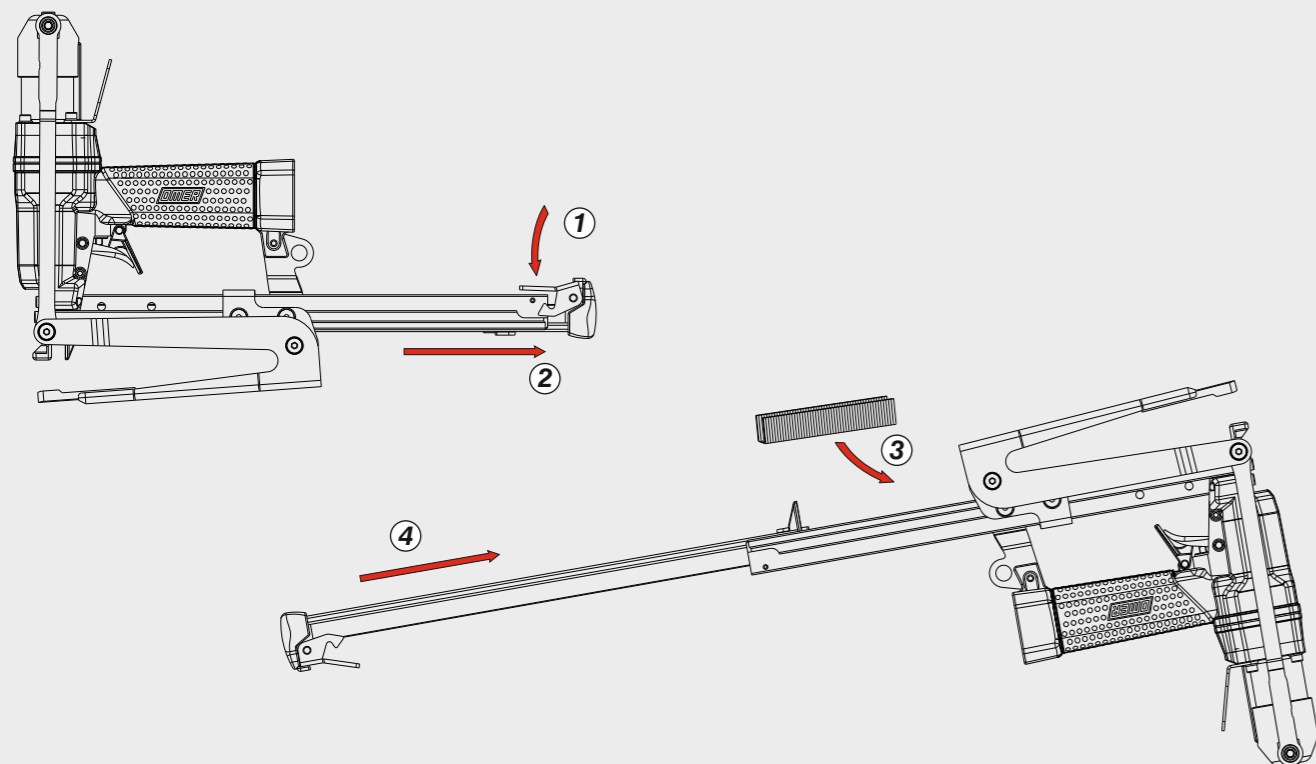

| | |
|--|-----------------|
| Manuale d'uso, manutenzione e parti di ricambio | Parte 2 |
| Manual for use, maintenance and spare parts | Part 2 |
| Bedienungs- und Wartungshandbuch sowie Ersatzteilleiste | Teil 2 |
| Mode d'emploi, de maintenance et pièces de rechange | Partie 2 |
| Manual de uso, mantenimiento y recambios | Part 2 |
| Εγχειρίδιο χρήσης, συντήρησης και ανταλλακτικών | Μέρος 2 |
| Manual de uso, manutenção e peças sobresselentes | Parte 2 |
| Handleiding voor gebruik, onderhoud en wisselstukken | Deel 2 |
| Kullanım, bakım ve yedek parça kılavuzu | Kısım 2 |



PL50.16 LJ-03

cod. 11567530-03



| Dati tecnici Technical data Technische Daten | Caractéristiques techniques Datos técnicos Τεχνικά χαρακτηριστικά | Dados técnicos Technische gegevens Teknik veriler | |
|---|---|---|---|
| Misure impiegabili mm Lengths mm Verwendbare Nagellänge mm | Dimensions utiles mm Medidas de longitud mm Μήκος Αναλωσίμου - mm | Medidas utilizáveis mm Toepasbare afmetingen mm Boy mm | 10 ÷ 16 |
| Capacità caricatore n° punti Magazine capacity Magazinkapazität Nägel | Capacité chargeur n° de points Capacidad cargador n° puntos Δωσατοτητα γεμιστερα | Capacidade carregador n° pontos Capaciteit magazijn in aantal spijkers Dergi kapasitesi | 210 |
| Pressione d'esercizio Operating pressure Betriebsdruck | Pression d'exercice Presión de servicio Πίεση λειτουργίας | Pressão de serviço Werkdruk Çalışma basıncı | 4,5 ÷ 6,5 bar 65 ÷ 95 psi |
| Consumo aria litri/colpo Air consumption litres/stroke Luftverbrauch Liter/Schuss | Consommation d'air litres/coup Consumo aire litros/golpe Κατανάλωση αέρα - λίτρα/βολή | Consumo ar litros/disparo Luchtverbruik liter/slag Litre/vuruş hava tüketimi | 0,20 |
| Peso kg Weight kg Gewicht kg | Poids kg Peso kg Βάρος - kg | Peso kg Gewicht in kg Ağırlık kg | 1,85 |
| Dimensioni mm Dimensions mm Abmessungen mm | Dimensions mm Dimensiones mm Διαστάσεις mm | Dimensões mm Afmetingen mm Boyutlar mm | 350x64x249 (LxWxH) |
| UNI EN 12549 :2009 | UNI EN ISO 4871 :2009 | | |
| Pressione sonora in pos. operatore Sound pressure in operator's position Schalldruck am Arbeitsplatz | Pression sonore poste Opérateur Presión sonora en la pos. del operador Ηχητική πίεση στη θέση του Χειριστή | Pressão sonora na posição Operador Geluidsdruk op de werkplaats Operatör pozisyonunda ses basıncı | 88 dB(A) (K= 4 dB) |
| UNI EN 12549 :2009 | UNI EN ISO 3746 :2011 | UNI EN ISO 4871 :2009 | |
| Potenza sonora emessa Sound power emitted Emittierte Schallleistung | Puissance sonore émise Potencia sonora emitida Εκπεμπόμενη ηχητική ισχύς | Potência sonora emitida Geëmitteerd geluidsvermogen Çıkan ses gücü (ses desibel) | 95 dB(A) (K= 4 dB) |
| UNI CEN ISO/TS 8662-11 :2006 | UNI EN ISO 5349-2 :2004 | UNI EN 12096 :1999 | |
| Emissione vibratoria sull'impugnatura Vibratory emissions on handle Vibrationsemission am Griff | Émission vibratoire sur la prise en main Emisión de vibraciones en la empuñadura Εκπεμπόμενες δονήσεις στη λαβή | Emissão vibratória na empunhadura Trillingsemissie op de handgreep Tutamak üzerinde vibrasyon emisyonları | 3,15 m/s² (K= 2 m/s ²) |

Stapling results

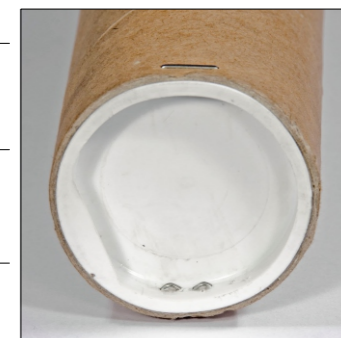

Tipo di punto
Type of fastener
Befestigungsmittel
Type de rivet
Tipo de punto
Τύπος αναλωσίμου
Tipo de agrafó
Type nietjes
Zimba ve çivi tipleri

50

0,50x1,25

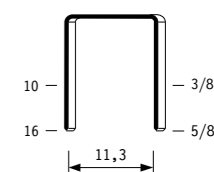

Crown: .484" (1/2")
Gauge: 20

Parti di ricambio - Spare parts - Ersatzteile - Pièces de rechange - Recambios
Ανταλλακτικά - Partes sobresselentes - Wisselstukken - Yedek parçalar

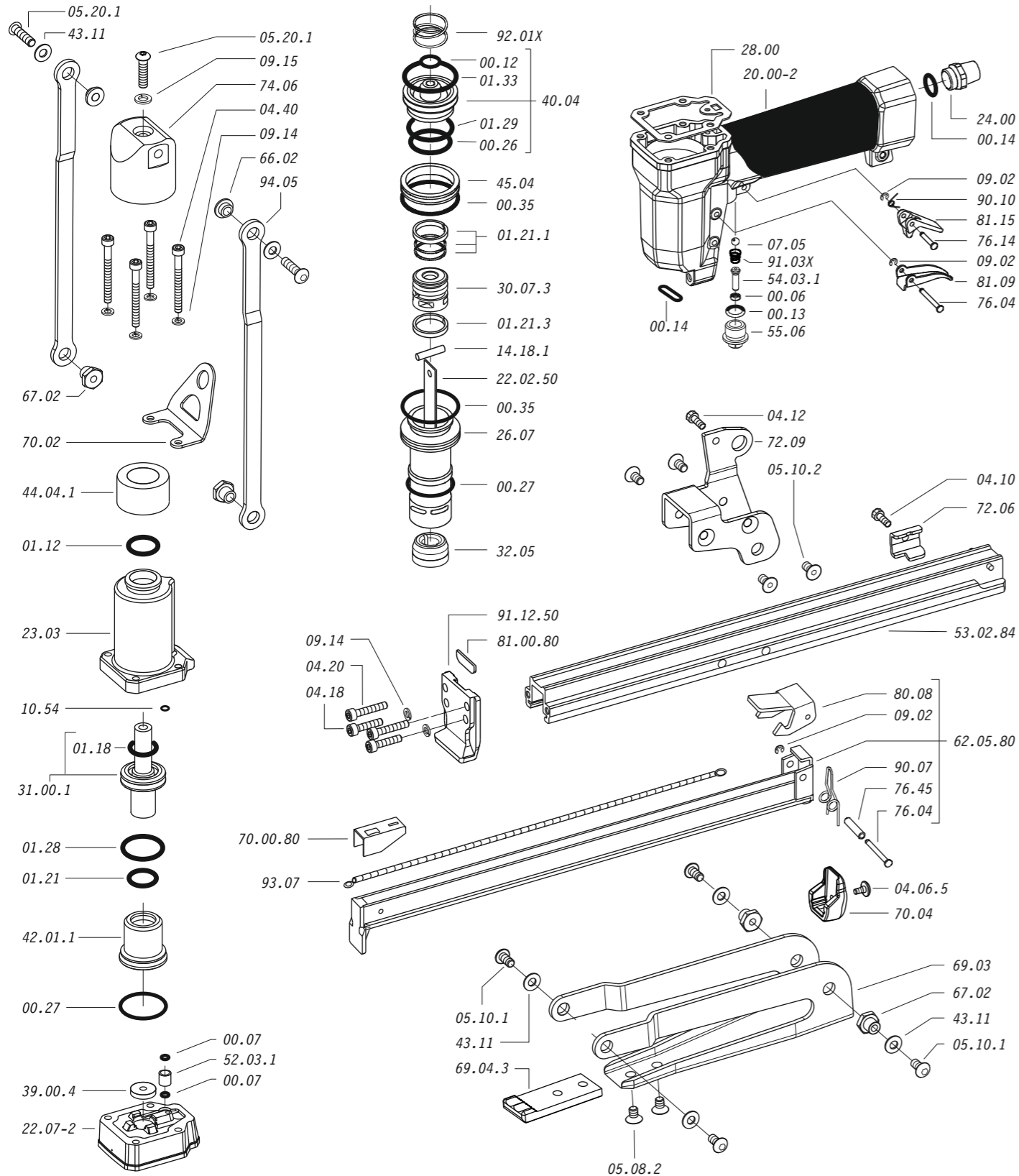

Dotazioni - Equipment - Ausstattung - Outillage - Dotaciones - Εξοπλισμός
Dotações - Uitrusting - Donanımlar

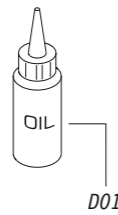

PL50.16 LJ-03

cod. 11567530-03

Parti di ricambio - Spare parts - Ersatzteile - Pièces de rechange - Recambios
Ανταλλακτικά - Partes sobresselentes - Wisselstukken - Yedek parçalar

| Cod. | Descrizione | Description |
|----------|---------------------|-----------------|
| 00.06 | O-Ring | O-Ring |
| 00.07 | O-Ring | O-Ring |
| 00.12 | O-Ring | O-Ring |
| 00.13 | O-Ring | O-Ring |
| 00.14 | O-Ring | O-Ring |
| 00.26 | O-Ring | O-Ring |
| 00.27 | O-Ring | O-Ring |
| 00.35 | O-Ring | O-Ring |
| 01.12 | O-Ring | O-Ring |
| 01.18 | O-Ring | O-Ring |
| 01.21 | O-Ring | O-Ring |
| 01.21.1 | Guarnizione | Gasket |
| 01.21.3 | Guarnizione | Gasket |
| 01.28 | O-Ring | O-Ring |
| 01.29 | O-Ring | O-Ring |
| 01.33 | O-Ring | O-Ring |
| 04.06.5 | Vite | Screw |
| 04.10 | Vite | Screw |
| 04.12 | Vite | Screw |
| 04.18 | Vite | Screw |
| 04.20 | Vite | Screw |
| 04.40 | Vite | Screw |
| 05.08.2 | Vite | Screw |
| 05.10.1 | Vite | Screw |
| 05.10.2 | Vite | Screw |
| 05.20.1 | Vite | Screw |
| 07.05 | Sfera | Ball |
| 07.30 | Chiave esagonale | Hex. bar wrench |
| 09.02 | Anello elastico | Elastic ring |
| 09.14 | Rondella | Washer |
| 09.15 | Rondella | Washer |
| 10.54 | O-Ring | O-Ring |
| 14.18.1 | Spina | Pin |
| 20.00-2 | Corpo | Body |
| 22.07-2 | Testa | Head |
| 23.03 | Testa superiore | Head |
| 24.00 | Silenziatore | Silencer |
| 26.07 | Cilindro | Cylinder |
| 28.00 | Guarnizione | Gasket |
| 30.07.3 | Pistone | Piston |
| 31.00.1 | Pistone ganascia | Jaws Piston |
| 32.05 | Ammortizzatore | Bumper |
| 39.00.4 | Guarnizione scarico | Exhaust gasket |
| 40.04 | Valvola completa | Valve ass'y |
| 42.01.1 | Anello superiore | Upper ring |
| 43.11 | Rondella | Washer |
| 44.04.1 | Ammortizzatore | Bumper |
| 45.04 | Anello valvola | Ring |
| 52.03.1 | Distanziale | Pacer |
| 54.03.1 | Pulsante | Trigger valve |
| 55.06 | Raccordo | Bush |
| 66.02 | Boccola | Bush |
| 67.02 | Boccola | Bush |
| 69.03 | Ganascia | Jaws |
| 69.04.3 | Ribattitore | Riveter |
| 70.02 | Supporto | Support |
| 70.04 | Protezione | Guard |
| 72.06 | Fermo carrello | Slider-Stop |
| 72.09 | Reggicaricatore | Support |
| 74.06 | Staffa | Bracket |
| 76.04 | Perno | Pin |
| 76.14 | Perno | Pin |
| 76.45 | Perno molla | Pin |
| 80.08 | Grilletto chiusura | Trigger |
| 81.09 | Grilletto comando | Trigger |
| 81.15 | Controgrilletto | Safety |
| 90.07 | Molla | Spring |
| 90.10 | Molla | Spring |
| 91.03X | Molla | Spring |
| 92.01X | Molla | Spring |
| 93.07 | Molla | Spring |
| 94.05 | Tirante | Connecting rod |
| 22.02.50 | Battente | Driver |
| 53.02.84 | Caricatore | Magazine |
| 62.05.80 | Carrello | Slider |
| 70.00.80 | Spingipunto | Pusher |
| 81.00.80 | Controtestina | Nose |
| 91.12.50 | Testina | Nose plate |
| D01 | Bocchetta olio | Oiler |

Guarnizioni - O-Rings - Dichtungen - Joints toriques - Juntas - Δακτύλιος στεγανοποίησης - Vedantes - O-ringen - Contalar

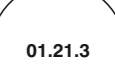
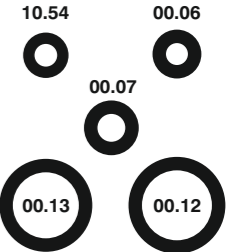
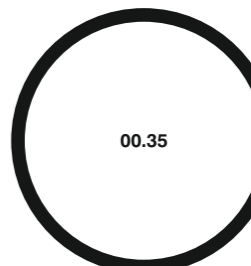
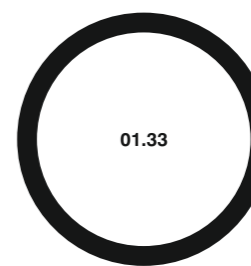
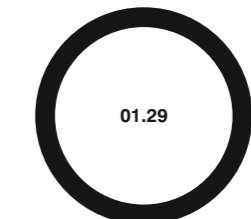
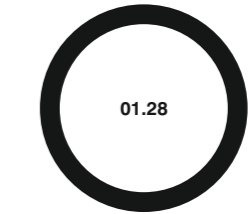
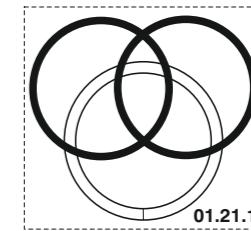
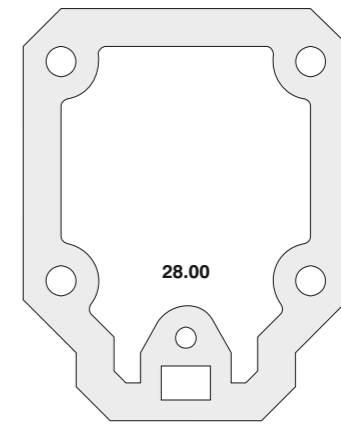

00.70.8

PL50.16 LJ-03

cod. 11567530-03

Indice di modifica
Upgrade number

5

Disinceppamento - Jam clearing - Staubeseitigung - Décoincement - Desatascamiento - Απεμπλοκή
Desencravamento - Deblokkering bij vastlopen - Σίκισμα giderme

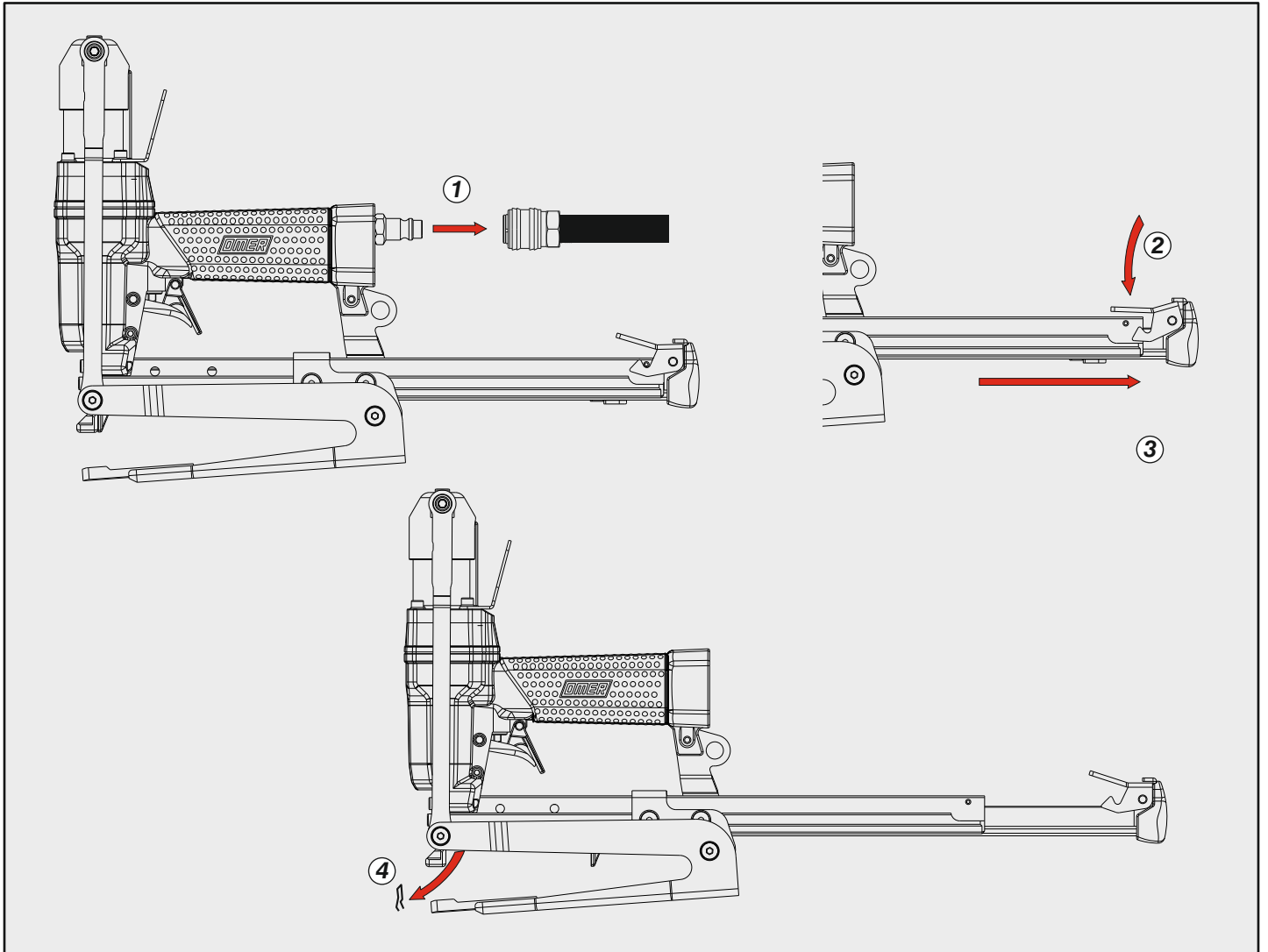

Caratteristiche - Features - Merkmale - Caractéristiques - Características - Χαρακτηριστικά - Características - Kenmerken - Özellikler

Spessore
Thickness

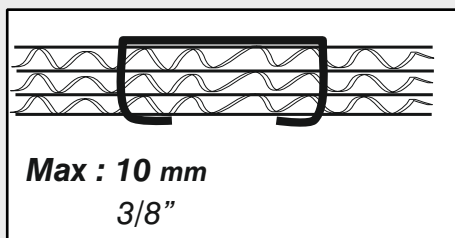
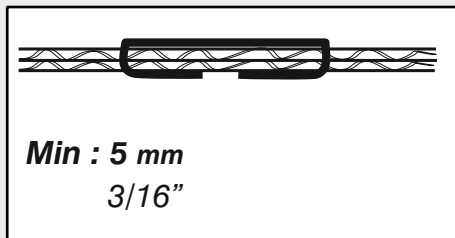

Dimensioni Ganascia
Jaw Dimension

