

**Azionamento a contatto**  
Contact actuation

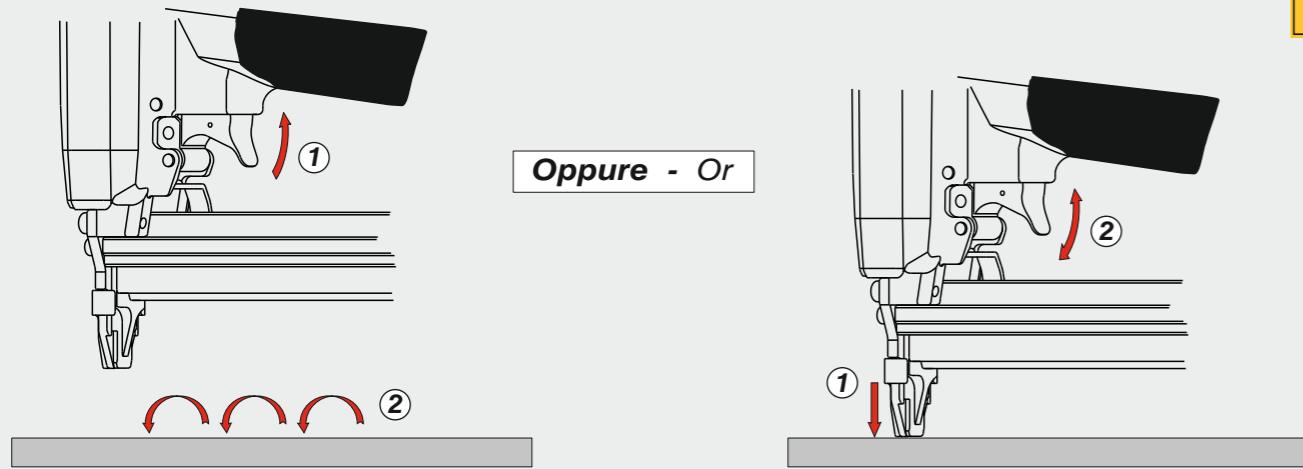

Caricamento - Loading - Laden - Chargement - Carga - Γέμισμα - Carregamento - Laden - Yükleme

**Caricamento da sotto**  
Bottom load magazine

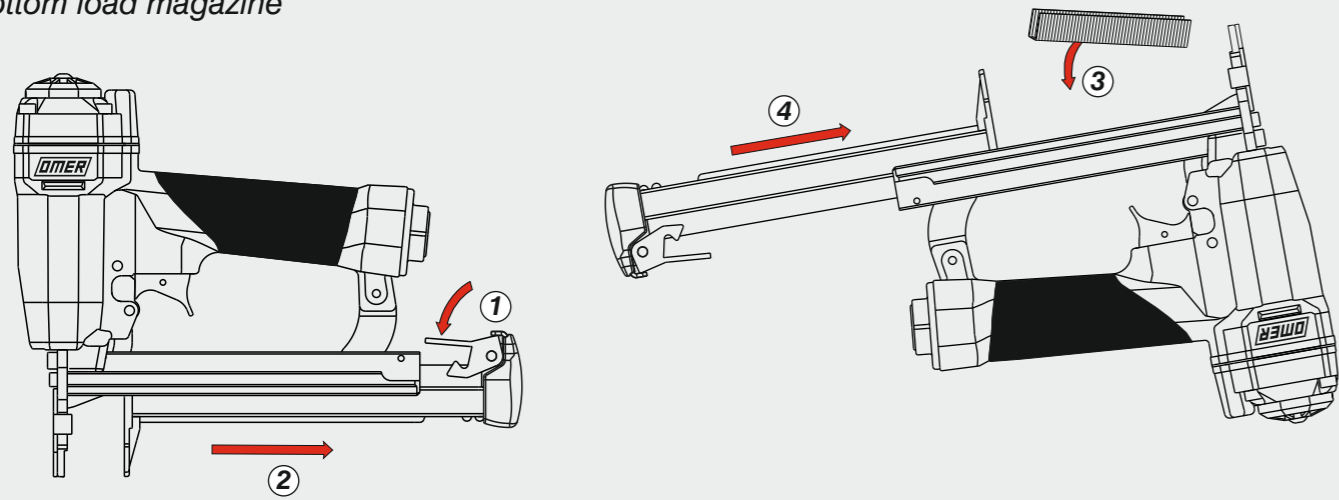

Disinceppamento - Jam clearing - Staubeseitigung - Décoincement - Desatascamiento - Απεμπλοκή  
Desenclavamento - Deblokkering bij vastlopen - Sıkışma giderme

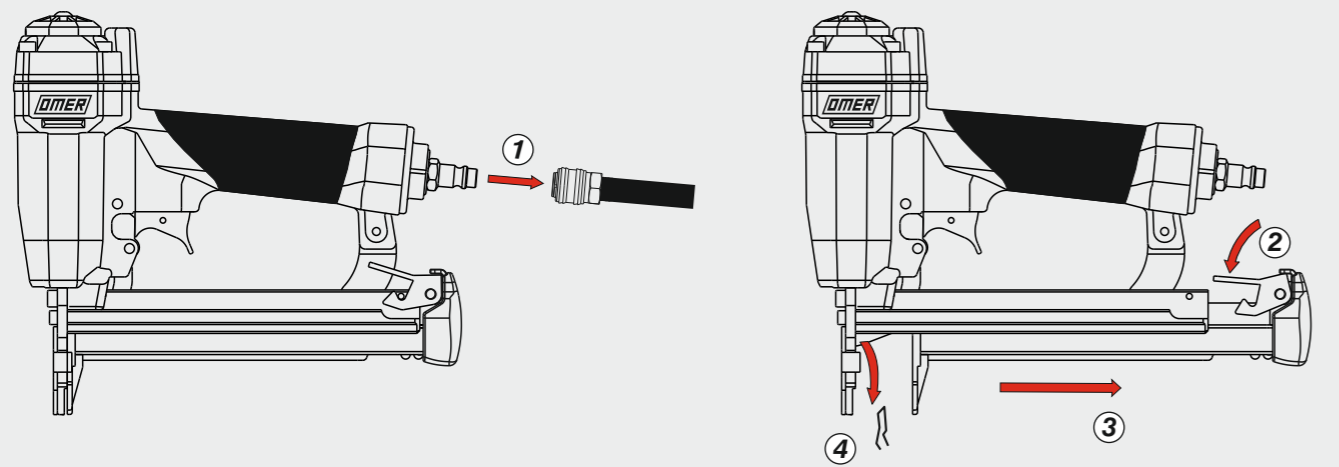

<b>Manuale d'uso, manutenzione e parti di ricambio</b>	<b>Parte 2</b>
<b>Manual for use, maintenance and spare parts</b>	<b>Part 2</b>
<b>Bedienungs- und Wartungshandbuch sowie Ersatzteilleiste</b>	<b>Teil 2</b>
<b>Mode d'emploi, de maintenance et pièces de rechange</b>	<b>Partie 2</b>
<b>Manual de uso, mantenimiento y recambios</b>	<b>Part 2</b>
<b>Εγχειρίδιο χρήσης, συντήρησης και ανταλλακτικών</b>	<b>Μέρος 2</b>
<b>Manual de uso, manutenção e peças sobresselentes</b>	<b>Parte 2</b>
<b>Handleiding voor gebruik, onderhoud en wisselstukken</b>	<b>Deel 2</b>
<b>Kullanım, bakım ve yedek parça kılavuzu</b>	<b>Kısım 2</b>



**4097.25 SL**

cod. 1223040



**Warning:** Please read the instructions and warnings for this tool carefully before use. Failure to do so could lead to serious injury.

Dati tecnici Technical data Technische Daten	Caractéristiques techniques Datos técnicos Τεχνικά χαρακτηριστικά	Dados técnicos Technische gegevens Teknik veriler	
<b>Misure impiegabili mm</b> Lengths mm Verwendbare Nagellänge mm	Dimensions utiles mm Medidas de longitud mm Μήκος Αναλωσίμου - mm	Medidas utilizáveis mm Toepasbare afmetingen mm Boy mm	<b>12 ÷ 25</b>
<b>Capacità caricatore n° punti</b> Magazine capacity Magazinkapazität Nägel	Capacité chargeur n° de points Capacidad cargador n° puntos Δωσατοτητα γεμιστερα	Capacidade carregador n° pontos Capaciteit magazijn in aantal spijkers Dergi kapasitesi	<b>135</b>
<b>Pressione d'esercizio</b> Operating pressure Betriebsdruck	Pression d'exercice Presión de servicio Πίεση λειτουργίας	Pressão de serviço Werkdruk Çalışma basıncı	<b>5 ÷ 6,5 bar 70 ÷ 95 psi</b>
<b>Consumo aria litri/colpo</b> Air consumption litres/stroke Luftverbrauch Liter/Schuss	Consumation d'air litres/coup Consumo aire litros/golpe Κατανάλωση αέρα - λίτρα/βολή	Consumo ar litros/disparo Luchtverbruik liter/slag Litre/vuruş hava tüketimi	<b>0,41</b>
<b>Peso kg</b> Weight kg Gewicht kg	Poids kg Peso kg Βάρος - kg	Peso kg Gewicht in kg Ağırlık kg	<b>1,20</b>
<b>Dimensioni mm</b> Dimensions mm Abmessungen mm	Dimensions mm Dimensiones mm Διαστάσεις mm	Dimensões mm Afmetingen mm Boyutlar mm	<b>226x50x245</b> (LxWxH)

<b>UNI EN 12549 :2009</b>	<b>UNI EN ISO 4871 :2009</b>		
<b>Pressione sonora in pos. operatore</b> Sound pressure in operator's position Schalldruck am Arbeitsplatz	Pression sonore poste Opérateur Presión sonora en la pos. del operador Ηχητική πίεση στη θέση του Χειριστή	Pressão sonora na posição Operador Geluidsdruk op de werkplaats Operatör pozisyonunda ses basıncı	<b>81 dB(A)</b> (K= 4 dB)

<b>UNI EN 12549 :2009</b>	<b>UNI EN ISO 3746 :2011</b>	<b>UNI EN ISO 4871 :2009</b>	
<b>Potenza sonora emessa</b> Sound power emitted Emittierte Schalleistung	Puissance sonore émise Potencia sonora emitida Εκπεμπόμενη ηχητική ισχύς	Potência sonora emitida Geëmitteerd geluidsvermogen Çıkan ses gücü (ses desibel)	<b>89 dB(A)</b> (K= 4 dB)

<b>UNI CEN ISO/TS 8662-11 :2006</b>	<b>UNI EN ISO 5349-2 :2004</b>	<b>UNI EN 12096 :1999</b>	
<b>Emissione vibratoria sull'impugnatura</b> Vibratory emissions on handle Vibrationsemission am Griff	Émission vibratoire sur la prise en main Emisión de vibraciones en la empuñadura Εκπεμπόμενες δονήσεις στη λαβή	Emissão vibratória na empunhadura Trillingsemissie op de handgreep Tutamak üzerinde vibrasyon emisyonları	<b>&lt;2,5 m/s<sup>2</sup></b> (K= 2 m/s <sup>2</sup> )

**Tipo di punto**  
Type of fastener  
Befestigungsmittel  
Type de rivet  
Tipo de punto  
Τύπος αναλωσίμου  
Tipo de agrafó  
Type nietjes  
Zimba ve çivi tipleri

**4097**

0,65x0,95

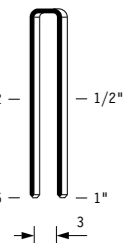

Crown: .170" (3/16")  
Gauge: 21

**40**

0,65x0,95

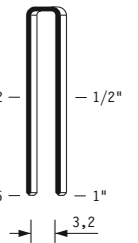

Crown: .180" (3/16")  
Gauge: 21

1223040\_409725SL\_2\_rev20\_25/09/2020\_LA

Parti di ricambio - Spare parts - Ersatzteile - Pièces de rechange - Recambios  
Ανταλλακτικά - Partes sobresselentes - Wisselstukken - Yedek parçalar

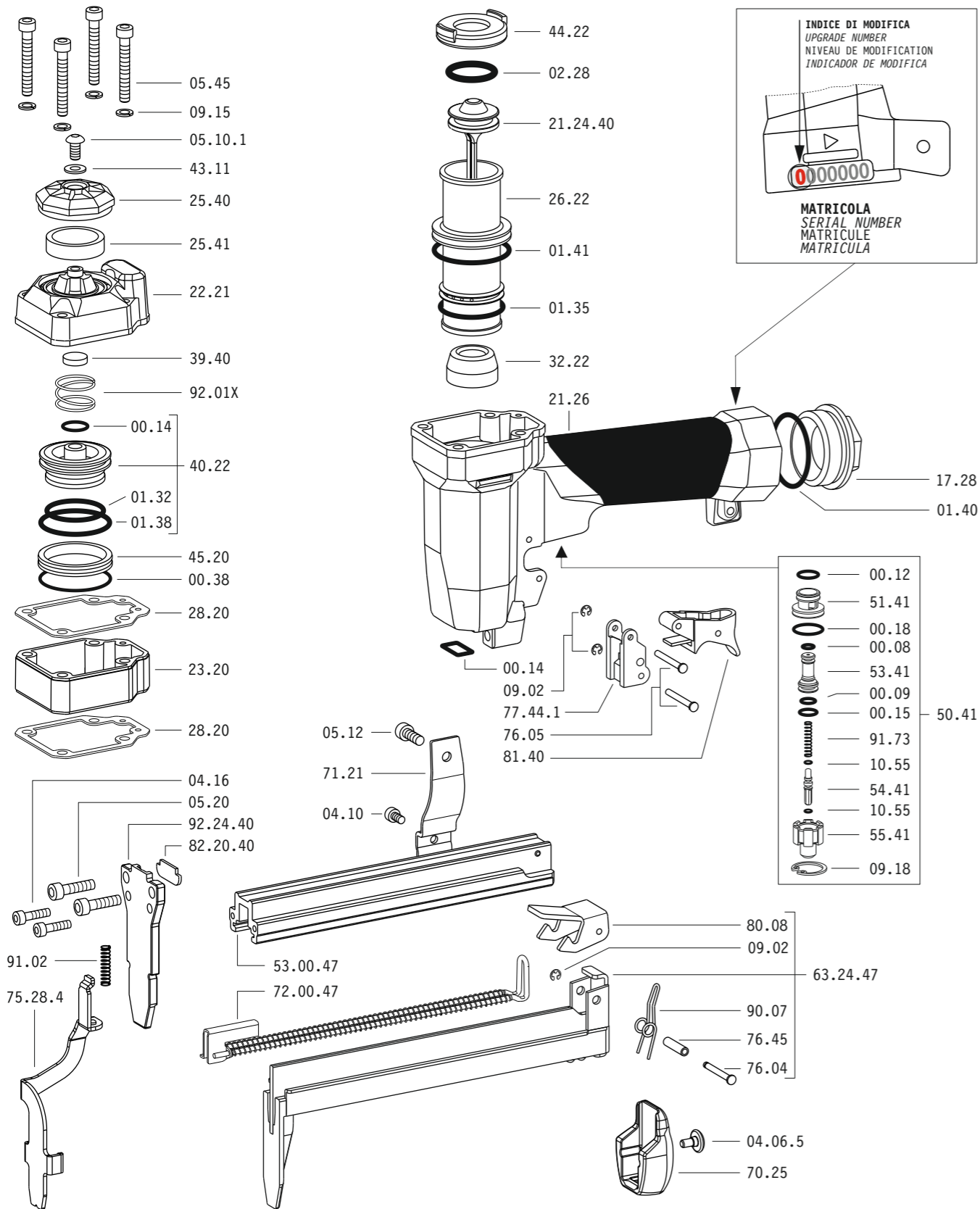

Dotazioni - Equipment - Ausstattung - Outillage - Dotaciones - Εξοπλισμός  
Dotações - Uitrusting - Donanımlar

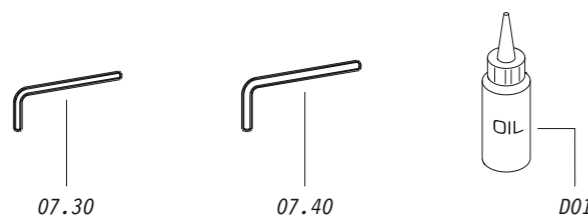

**4097.25 SL**

cod. 1223040

Parti di ricambio - Spare parts - Ersatzteile - Pièces de rechange - Recambios  
Ανταλλακτικά - Partes sobresselentes - Wisselstukken - Yedek parçalar

Cod.	Descrizione	Description
00.08	O-Ring	O-Ring
00.09	O-Ring	O-Ring
00.12	O-Ring	O-Ring
00.14	O-Ring	O-Ring
00.15	O-Ring	O-Ring
00.18	O-Ring	O-Ring
00.38	O-Ring	O-Ring
01.32	O-Ring	O-Ring
01.35	O-Ring	O-Ring
01.38	O-Ring	O-Ring
01.40	O-Ring	O-Ring
01.41	O-Ring	O-Ring
02.28	O-Ring	O-Ring
04.06.5	Vite	Screw
04.10	Vite	Screw
04.16	Vite	Screw
05.10.1	Vite	Screw
05.12	Vite	Screw
05.20	Vite	Screw
05.45	Vite	Screw
07.30	Chiave esagonale	Hex. bar wrench
07.40	Chiave esagonale	Hex. bar wrench
09.02	Anello elastico	Elastic ring
09.15	Rondella	Washer
09.18	Anello elastico	Elastic ring
10.55	O-Ring	O-Ring
17.28	Tappo	Inlet cap
21.26	Corpo	Body
22.21	Testa	Head
23.20	Prolunga	Extension
25.40	Deflettore	Exhaust deflector
25.41	Silenziatore	Silencer
26.22	Cilindro	Cylinder
28.20	Guarnizione testa	Head gasket
32.22	Ammortizzatore	Bumper
39.40	Guarnizione scarico	Exhaust seal
40.22	Valvola completa	Valve ass'y
43.11	Rondella	Washer
44.22	Guarnizione	Gasket
45.20	Anello valvola	Ring
50.41	Pulsante completo	Trigger valve ass'y
51.41	Boccola pulsante	Trigger valve housing
53.41	Pistone servovalvola	Valve piston
54.41	Pulsante	Trigger valve
55.41	Raccordo pulsante	Bush
70.25	Protezione	Guard
71.21	Reggicaricatore	Support
75.28.4	Sicura	Safety
76.04	Perno	Pin
76.05	Perno	Pin
76.45	Perno molla	Pin
77.44.1	Guida sicura	Safety guide
80.08	Grilletto chiusura	Trigger
81.40	Grilletto comando	Trigger
90.07	Molla	Spring
91.02	Molla	Spring
91.73	Molla	Spring
92.01X	Molla	Spring
21.24.40	Battente	Driver
53.00.47	Caricatore	Magazine
63.24.47	Carrello	Slider
72.00.47	Spingipunto	Pusher
82.20.40	Controtestina	Nose
92.24.40	Testina	Nose plate
D01	Bocchetta olio	Oiler

Guarnizioni - O-Rings - Dichtungen - Juntas - Δακτύλιος στεγανοποίησης - Vedantes - O-ringen - Contalar

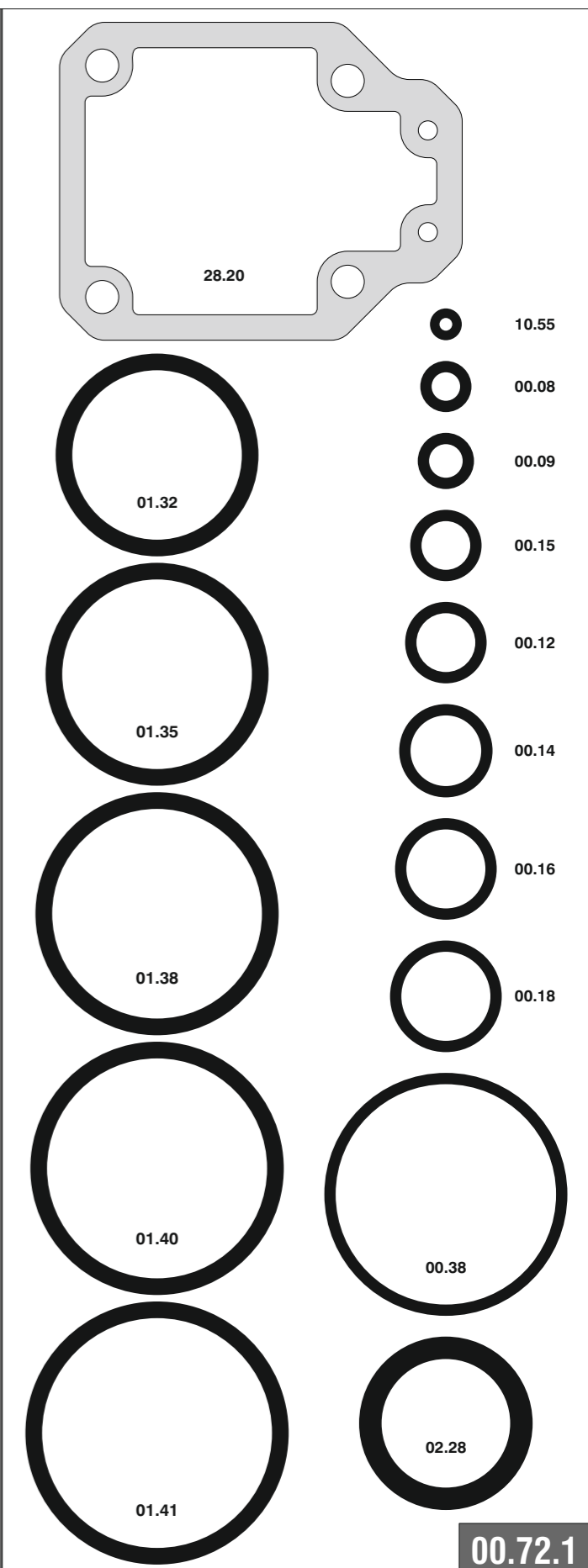

**4097.25 SL**

cod. 1223040

Indice di modifica  
Upgrade number

**2**