

Azionamento singolo con doppia attivazione
 Single actuation with dual activation

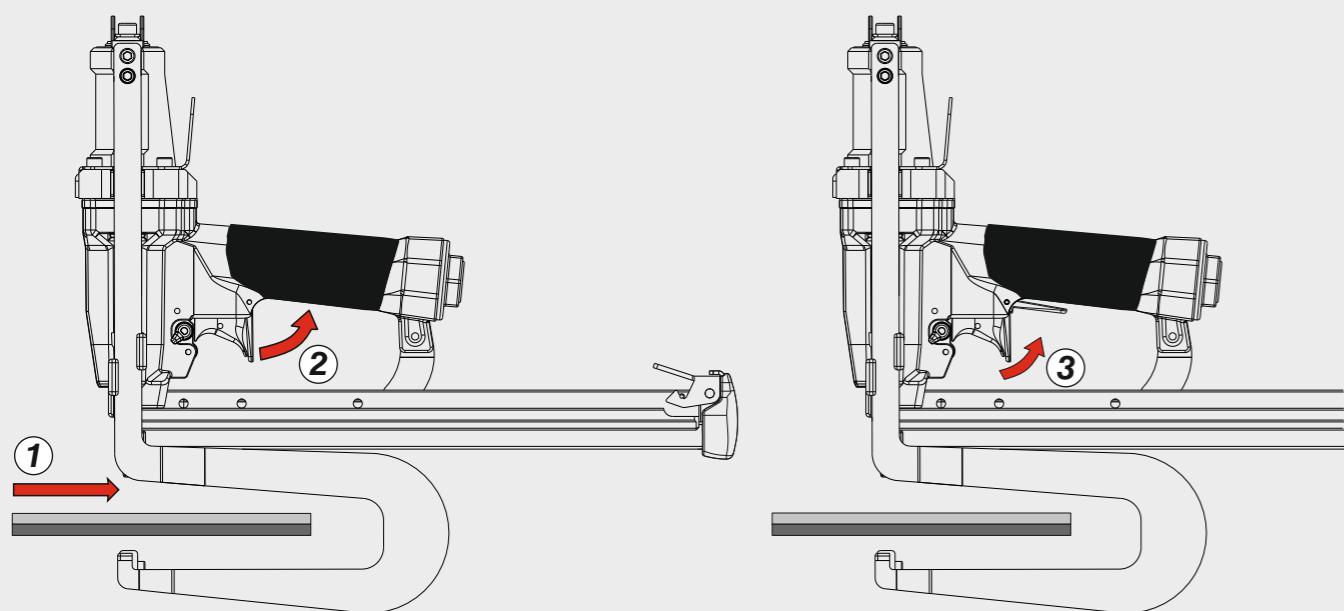

Manuale d'uso, manutenzione e parti di ricambio	Parte 2
Manual for use, maintenance and spare parts	Part 2
Bedienungs- und Wartungshandbuch sowie Ersatzteilleiste	Teil 2
Mode d'emploi, de maintenance et pièces de rechange	Partie 2
Manual de uso, mantenimiento y recambios	Part 2
Εγχειρίδιο χρήσης, συντήρησης και ανταλλακτικών	Μέρος 2
Manual de uso, manutenção e peças sobresselentes	Parte 2
Handleiding voor gebruik, onderhoud en wisselstukken	Deel 2
Kullanım, bakım ve yedek parça kılavuzu	Kısım 2
Användar-, underhålls- och reservdelshandbok	Del 2



PL 110 LJ

cod. 12368530



Dati tecnici Technical data Technische Daten Tekniska data	Caractéristiques techniques Datos técnicos Τεχνικά χαρακτηριστικά	Dados técnicos Technische gegevens Teknik veriler
--	---	---

Misure impiegabili Lengths Verwendbare Nagellänge Dimensioner som kan användas	Dimensions utiles Medidas de longitud Μήκος Αναλωσίμου	Medidas utilizáveis Toepasbare afmetingen Boy	12 ÷ 25
Capacità caricatore n° punti Magazine capacity Magazinkapazität: Nägel Magasinkapacitet: Antal punkter	Capacité chargeur n° de points Capacidad cargador n° puntos Δυνατότητα γεμιστέρα	Capacidade carregador n° pontos Capaciteit magazijn in aantal spijkers Dergi kapasitesi	160
Pressione d'esercizio Operating pressure Betriebsdruck Drifttryck	Pression d'exercice Presión de servicio Πίεση λειτουργίας	Pressão de serviço Werkdruk Çalışma basıncı	5 ÷ 6,5 bar 70 ÷ 95 psi
Consumo aria Air consumption Luftverbrauch Luftförbrukning	Consommation d'air Consumo aire Κατανάλωση αέρα	Consumo ar Luchtverbruik Hava tüketimi	0,44
Peso Weight Gewicht Vikt	Poids Peso Βάρος	Peso Gewicht Ağırlık	2,73
Dimensioni Dimensions Abmessungen Dimensioner (AxBxH)	Dimensions Dimensiones Διαστάσεις	Dimensões Afmetingen Boyutlar	367x70x330 (LxWxH)

Stapling results

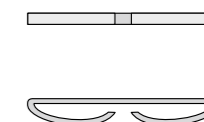

Tipo di punto
Type of fastener
Befestigungsmittel
Type de rivet
Tipo de punto
Τύπος αναλωσίμου
Tipo de agrafó
Type nietjes
Zimba ve çivi tipleri
Typ av stygn

110

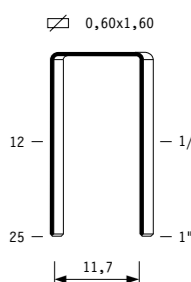

Crown: .512" (1/2")
Gauge: 18

EN 12549 :2009 EN ISO 4871 :2009 Pressione sonora in pos. operatore Sound pressure in operator's position Schalldruck am Arbeitsplatz Ljudtryck på operatörsplatsen	Pression sonore poste Opérateur Presión sonora en la pos. del operador Ηχητική πίεση στη θέση του χειριστή Operatör pozisyonunda ses basıncı	Pressão sonora na posição Operador Geluidsdruk op de werkplaats Operatör pozisyonunda ses basıncı	87 dB(A) (K= 4 dB)
EN 12549 :2009 EN ISO 3746 :2011 EN ISO 4871 :2009 Potenza sonora emessa Sound power emitted Emitierte Schalleistung Avgiven ljudeffekt	Puissance sonore émise Potencia sonora emitida Εκπεμπόμενη ηχητική ισχύς	Potência sonora emitida Geëmitteerd geluidsvermogen Çıkan ses gücü (ses desibeli)	93 dB(A) (K= 4 dB)
CEN ISO/TS 8662-11 :2006 EN ISO 5349-2 :2004 EN 12096 :1999 Emissione vibratoria sull'impugnatura Vibratory emissions on handle Vibrationsemission am Griff Vibrationsemission på handtaget	Émission vibratoire sur la prise en main Emisión de vibraciones en la empuñadura Εκπεμπόμενες δονήσεις στη λαβή	Emissão vibratória na empunhadura Trillingsemissie op de handgreep Tutamak üzerinde vibrasyon emisyonları	4,70 m/s² (K= 2 m/s ²)

12368530_PL110LJ_3_rev21_22/03/2023_DV

Caricamento - Loading - Laden - Chargement - Carga - Γέμισμα - Carregamento - Laden - Yükleme - Laddning

Caricamento da sotto
Bottom load magazine

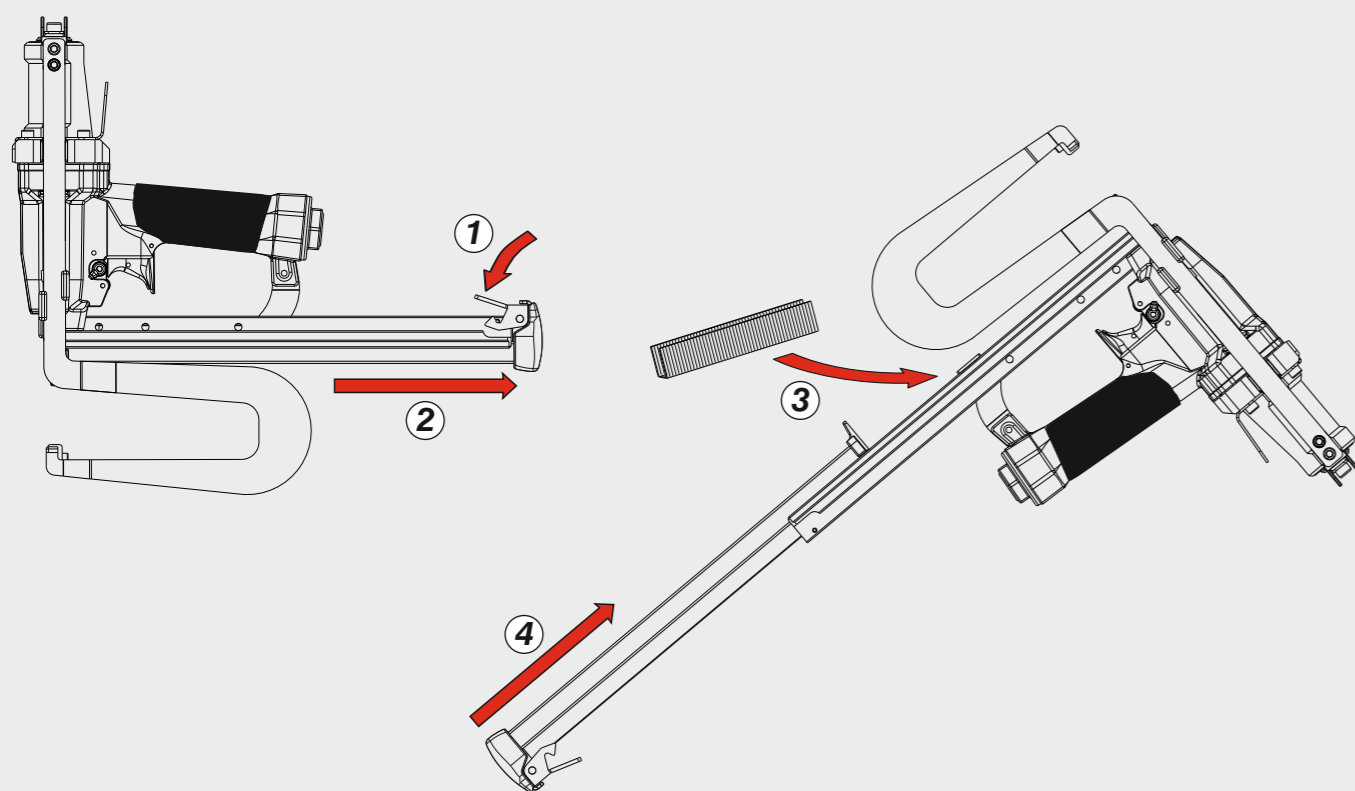

Parti di ricambio - Spare parts - Ersatzteile - Pièces de rechange - Recambios
Ανταλλακτικά - Partes sobresselentes - Wisselstukken - Yedek parçalar

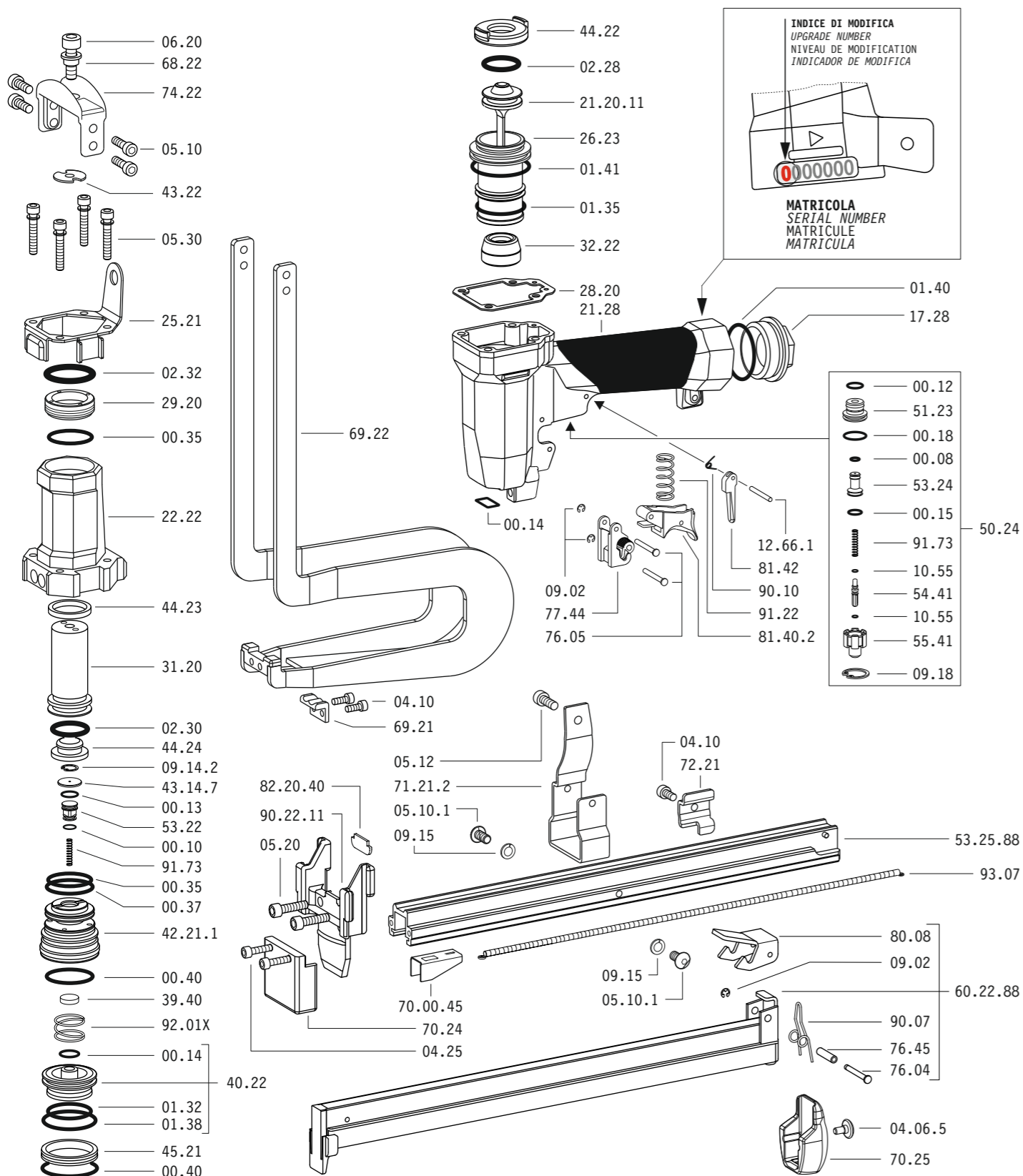

Dotazioni - Equipment - Ausstattung - Outillage - Dotaciones - Εξοπλισμός
Dotações - Uitrusting - Donanımlar

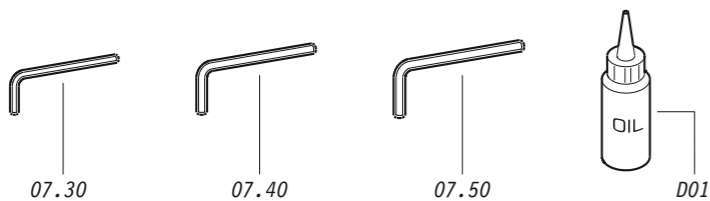

PL 110 LJ
cod. 12368530

Parti di ricambio - Spare parts - Ersatzteile - Pièces de rechange - Recambios
Ανταλλακτικά - Partes sobresselentes - Wisselstukken - Yedek parçalar

Cod.	Descrizione	Description
00.08	O-Ring	O-Ring
00.10	O-Ring	O-Ring
00.12	O-Ring	O-Ring
00.13	O-Ring	O-Ring
00.14	O-Ring	O-Ring
00.15	O-Ring	O-Ring
00.18	O-Ring	O-Ring
00.35	O-Ring	O-Ring
00.37	O-Ring	O-Ring
00.40	O-Ring	O-Ring
01.32	O-Ring	O-Ring
01.35	O-Ring	O-Ring
01.38	O-Ring	O-Ring
01.40	O-Ring	O-Ring
01.41	O-Ring	O-Ring
02.28	O-Ring	O-Ring
02.30	O-Ring	O-Ring
02.32	O-Ring	O-Ring
04.06.5	Vite	Screw
04.10	Vite	Screw
04.25	Vite	Screw
05.10	Vite	Screw
05.10.1	Vite	Screw
05.12	Vite	Screw
05.20	Vite	Screw
05.30	Vite	Screw
06.20	Vite	Screw
07.30	Chiave esagonale	Hex. bar wrench
07.40	Chiave esagonale	Hex. bar wrench
07.50	Chiave esagonale	Hex. bar wrench
09.02	Anello elastico	Elastic ring
09.14.2	Anello elastico	Elastic ring
09.15	Rondella	Washer
09.18	Anello elastico	Elastic ring
10.55	O-Ring	O-Ring
12.66.1	Spina	Pin
17.28	Tappo	Inlet cap
21.28	Corpo	Body
22.22	Testa	Head
25.21	Deflettore	Exhaust deflector
26.23	Cilindro	Cylinder
28.20	Guarnizione testa	Head gasket
29.20	Bronzina	Bronze ring
31.20	Pistone Ganascia	Jaw's piston
32.22	Ammortizzatore	Bumper
39.40	Guarnizione scarico	Exhaust seal
40.22	Valvola completa	Valve ass'y
42.21.1	Sede Valvola	Valve housing
43.14.7	Rondella	Washer
43.22	Rondella	Washer
44.22	Guarnizione	Gasket
44.23	Ammortizzatore Sup.	Upper bumper
44.24	Ammortizzatore Inf.	Lower bumper
45.21	Anello valvola	Ring
50.24	Pulsante completo	Trigger valve ass'y
51.23	Boccola pulsante	Trigger valve housing
53.22	Pistone servovalvola	Valve piston
53.24	Pistone servovalvola	Valve piston
54.41	Pulsante	Trigger valve
55.41	Raccordo pulsante	Bush
68.22	Distanziale rondella	Pacer
69.21	Ribattitore	Riveter
69.22	Gruppo ganascia	Jaw kit
70.24	Appoggio	Support
70.25	Protezione	Guard
71.21.2	Reggicaricatore	Support
72.21	Fermo carrello	Slider-Stop
74.22	Staffa	Hanger
76.04	Perno	Pin
76.05	Perno	Pin
76.45	Perno carter	Pin
77.44	Guida sicura	Safety guide
80.08	Grilletto chiusura	Trigger
81.40.2	Grilletto comando	Trigger
81.42	Controgrilletto	Trigger safety
90.07	Molla	Spring
90.10	Molla	Spring
91.22	Molla	Spring
91.73	Molla	Spring
92.01X	Molla	Spring
93.07	Molla	Spring
21.20.11	Battente	Driver
53.25.88	Caricatore	Magazine
60.22.88	Carrello	Slider
70.00.45	Spingipunto	Pusher
82.20.40	Controtestina	Nose
90.22.11	Testina	Nose plate
D01	Bocchetta olio	Oiler

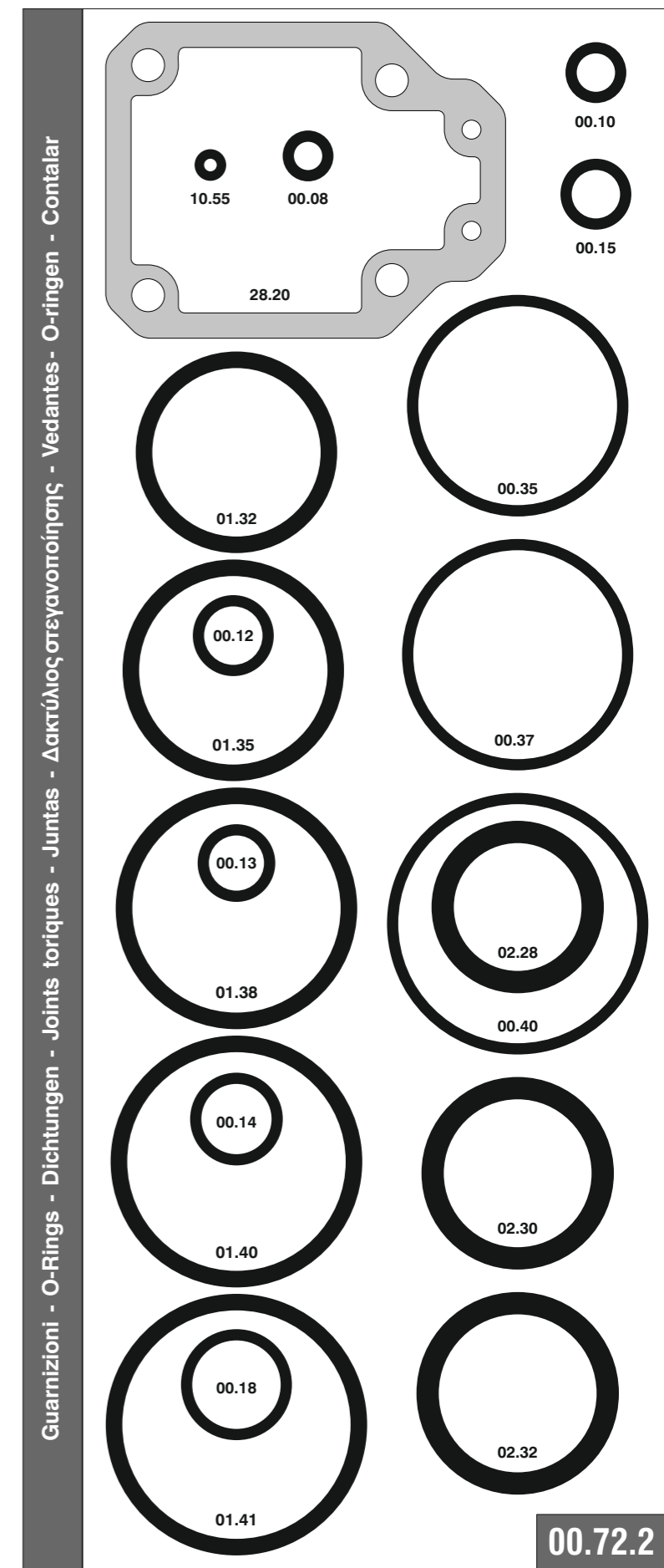

PL 110 LJ cod. 12368530 Indice di modifica **3**
Upgrade number

Disincemento - Jam clearing - Staubeseitigung - Décoincement - Desatascamiento - Απεμπλοκή
Desencravamento - Deblokkering bij vastlopen - Sıkışma giderme - Rensning av igensättningar

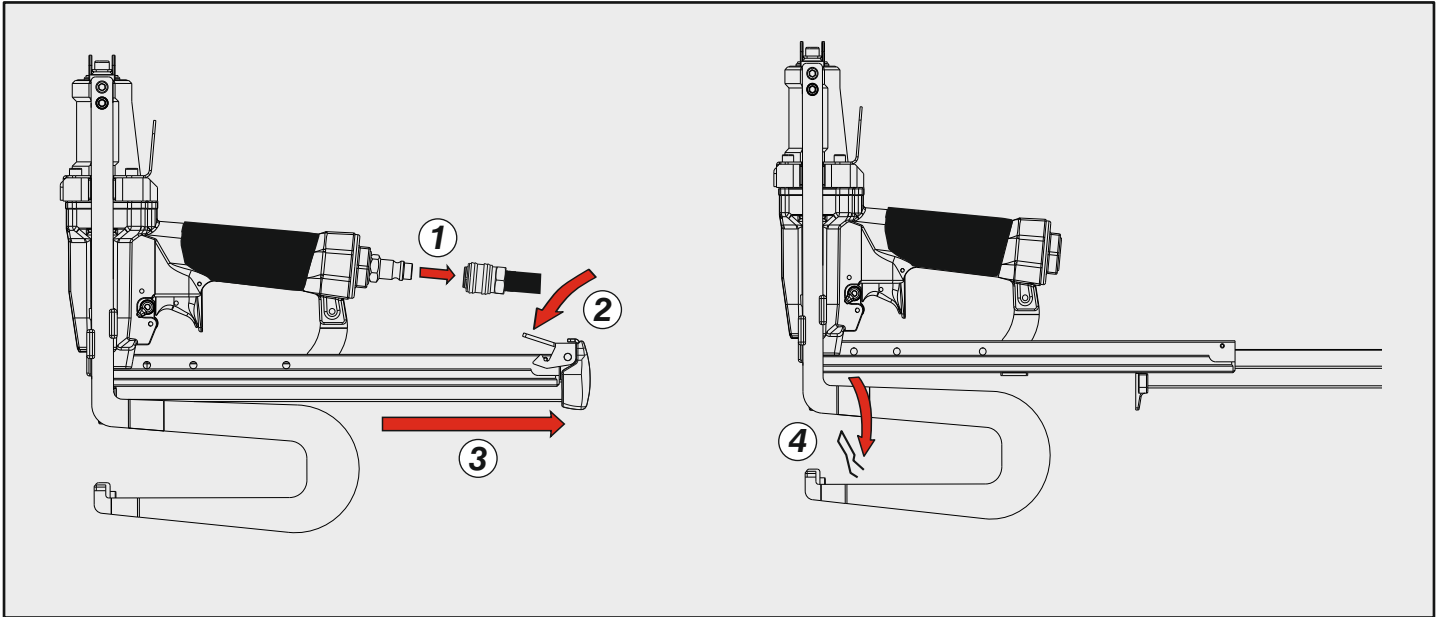

Caratteristiche - Features - Merkmale - Caractéristiques - Características
Χαρακτηριστικά - Características - Kenmerken - Özellikler - Funktionen

Selettore (ON/OFF)
Selector (ON/OFF)

