

Collegamento - Connection

Collegamento:
Connection:

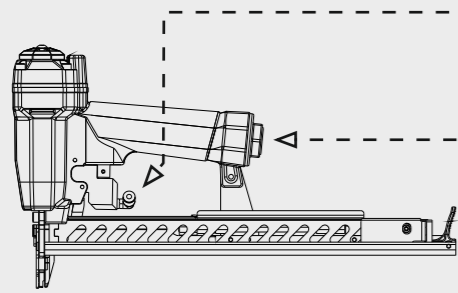

Valvola 3/2 NC
Valve 3/2 NC

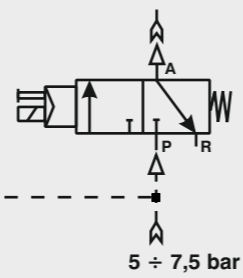

| | |
|--|-----------------|
| Manuale d'uso, manutenzione e parti di ricambio | Parte 2 |
| Manual for use, maintenance and spare parts | Part 2 |
| Bedienungs- und Wartungshandbuch sowie Ersatzteilleiste | Teil 2 |
| Mode d'emploi, de maintenance et pièces de rechange | Partie 2 |
| Manual de uso, mantenimiento y recambios | Part 2 |
| Εγχειρίδιο χρήσης, συντήρησης και ανταλλακτικών | Μέρος 2 |
| Manual de uso, manutenção e peças sobresselentes | Parte 2 |
| Handleiding voor gebruik, onderhoud en wisselstukken | Deel 2 |
| Kullanım, bakım ve yedek parça kılavuzu | Kısım 2 |
| Användar-, underhålls- och reservdelshandbok | Del 2 |



90.25 CLT-3

cod. 12370520-3

Caricamento - Loading - Laden - Chargement - Carga - Γέμισμα - Carregamento - Laden - Yükleme - Laddning

Caricamento da sopra
Top load magazine

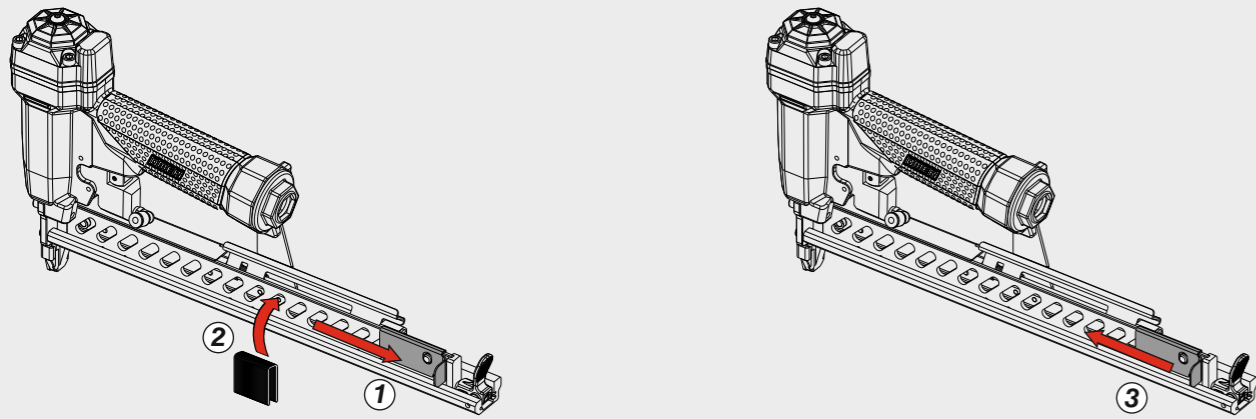

Disincerramento - Jam clearing - Staubeseitigung - Décoincement - Desatascamiento - Απεμπλοκή
Desencravamento - Deblokkering bij vastlopen - Σίκισμα giderme - Rensning av igensättning

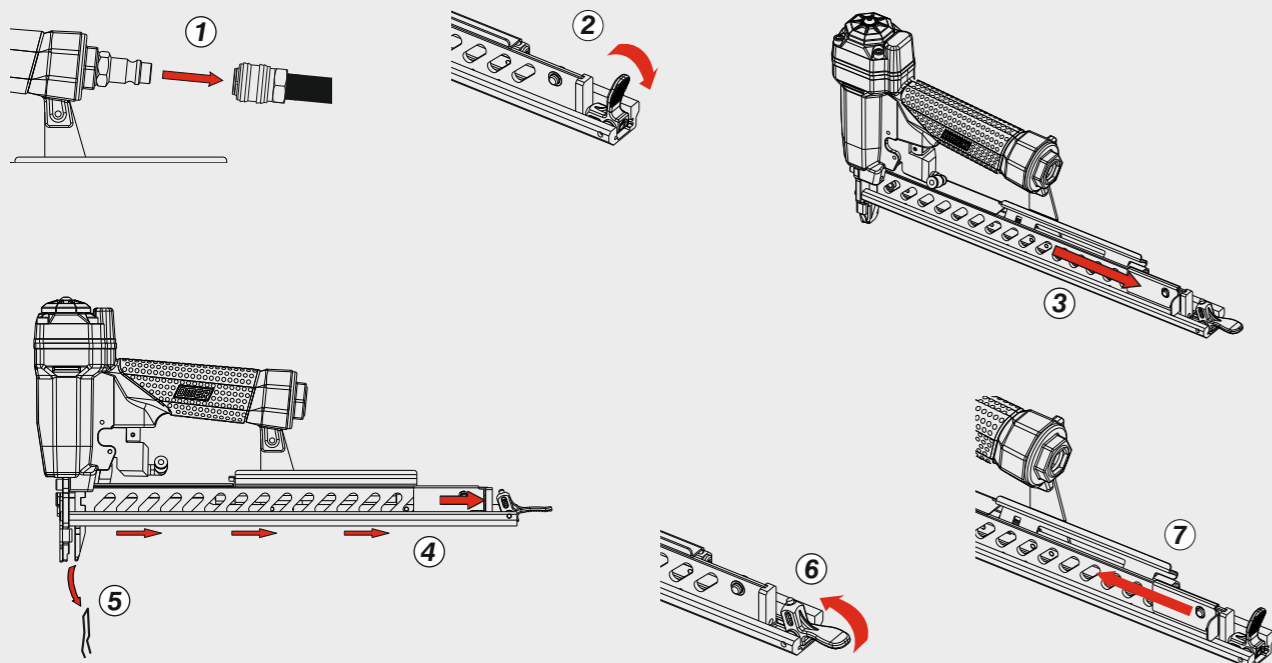

| | | |
|--|--|--|
| Dati tecnici Technical data Technische Daten Tekniska data | Caractéristiques techniques Datos técnicos Τεχνικά χαρακτηριστικά | Dados técnicos Technische gegevens Teknik veriler |
|--|--|--|

| | | | |
|--|--|--|---|
| Misure impiegabili Lengths Verwendbare Nagellänge Dimensioner som kan användas | Dimensions utiles Medidas de longitud Μήκος Αναλωσίμου | Medidas utilizáveis Toepasbare afmetingen Boy | 9 ÷ 25 |
| Capacità caricatore n° punti Magazine capacity Magazinkapazität Nägel Magasinkapacitet Antal punkter | Capacité chargeur n° de points Capacidad cargador n° puntos Δυνατότητα γεμιστέρα | Capacidade carregador n° pontos Capaciteit magazijn in aantal spijkers Dergi kapasitesi | 200 |
| Pressione d'esercizio Operating pressure Betriebsdruck Drifttryck | Pression d'exercice Presión de servicio Πίεση λειτουργίας | Pressão de serviço Werkdruk Çalışma basıncı | 5 ÷ 7,5 bar 70 ÷ 105 psi |
| Consumo aria Air consumption Luftverbrauch Luftförbrukning | Consommation d'air Consumo aire Κατανάλωση αέρα | Consumo ar Luchtverbruik Hava tüketimi | 0,31 |
| Peso Weight Gewicht Vikt | Poids Peso Βάρος | Peso Gewicht Ağırlık | 1,40 |
| Dimensioni Dimensions Abmessungen Dimensioner (AxBxH) | Dimensions Dimensiones Διαστάσεις | Dimensões Afmetingen Boyutlar | 380x50x211 (LxWxH) |
| EN 12549 :2009 EN ISO 3746 :2011 EN ISO 4871 :2009 | Potenza sonora emessa Sound power emitted Emitierte Schalleistung Avgiven ljudeffekt | Puissance sonore émise Potencia sonora emitida Εκπεμπόμενη ηχητική ισχύς | 91 dB(A) (K = 4 dB) |
| | Potência sonora emitida Geëmitteerd geluidsvermogen Çıkan ses gücü (ses desibeli) | | |

Tipo di punto
Type of fastener
Befestigungsmittel
Type de rivet
Tipo de punto
Τύπος αναλωσίμου
Tipo de agrafó
Type nietjes
Zimba ve çivi tipleri
Typ av stygn

90

1,00x1,25

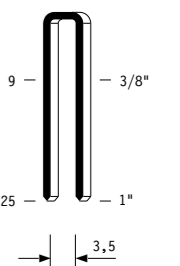

Crown: .217" (1/4")
Gauge: 18

12370520-3_9025CLT-3_3_rev21_09/03/2023 DV

**DO NOT
HANDHELD
THIS TOOL**



Parti di ricambio - Spare parts - Ersatzteile - Pièces de rechange - Recambios
Ανταλλακτικά - Partes sobresselentes - Wisselstukken - Yedek parçalar - Reservdelar

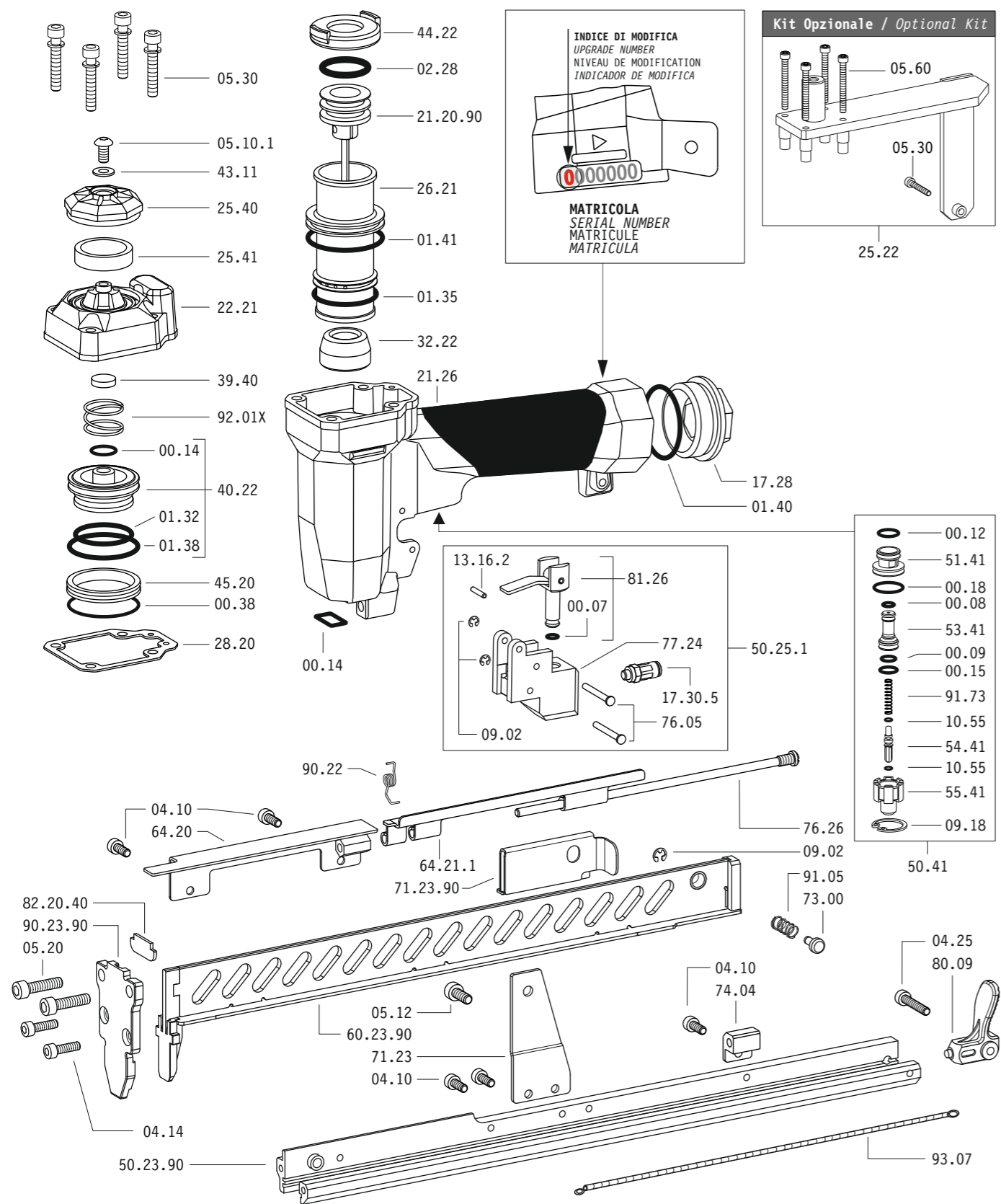

Dotazioni - Equipment - Ausstattung - Outillage - Dotaciones - Εξοπλισμός
Dotações - Uitrusting - Donanımlar - Utrustning



90.25 CLT-3

cod. 12370520-3

Parti di ricambio - Spare parts - Ersatzteile - Pièces de rechange - Recambios
Ανταλλακτικά - Partes sobresselentes - Wisselstukken - Yedek parçalar - Reservdelar

| Cod. | Descrizione | Description |
|----------|----------------------|-----------------------|
| 00.07 | O-Ring | O-Ring |
| 00.08 | O-Ring | O-Ring |
| 00.09 | O-Ring | O-Ring |
| 00.12 | O-Ring | O-Ring |
| 00.14 | O-Ring | O-Ring |
| 00.15 | O-Ring | O-Ring |
| 00.18 | O-Ring | O-Ring |
| 00.38 | O-Ring | O-Ring |
| 01.32 | O-Ring | O-Ring |
| 01.35 | O-Ring | O-Ring |
| 01.38 | O-Ring | O-Ring |
| 01.40 | O-Ring | O-Ring |
| 01.41 | O-Ring | O-Ring |
| 02.28 | O-Ring | O-Ring |
| 04.10 | Vite | Screw |
| 04.14 | Vite | Screw |
| 04.25 | Vite | Screw |
| 05.10.1 | Vite | Screw |
| 05.12 | Vite | Screw |
| 05.20 | Vite | Screw |
| 05.30 | Vite | Screw |
| 05.60 | Vite | Screw |
| 07.30 | Chiave esagonale | Hex. bar wrench |
| 07.40 | Chiave esagonale | Hex. bar wrench |
| 09.02 | Anello elastico | Elastic ring |
| 09.18 | Anello elastico | Elastic ring |
| 10.55 | O-Ring | O-Ring |
| 13.16.2 | Spina | Pin |
| 17.28 | Tappo | Inlet cap |
| 17.30.5 | Attacco | Connection |
| 21.26 | Corpo | Body |
| 22.21 | Testa | Head |
| 25.22 | Supporto | Support |
| 25.40 | Deflettore | Exhaust deflector |
| 25.41 | Silenziatore | Silencer |
| 26.21 | Cilindro | Cylinder |
| 28.20 | Guarnizione testa | Head gasket |
| 32.22 | Ammortizzatore | Bumper |
| 39.40 | Guarnizione scarico | Exhaust seal |
| 40.22 | Valvola completa | Valve ass'y |
| 43.11 | Rondella | Washer |
| 44.22 | Guarnizione | Gasket |
| 45.20 | Anello valvola | Ring |
| 50.25.1 | Comando a distanza | Remote control |
| 50.41 | Pulsante completo | Trigger valve ass'y |
| 51.41 | Boccola pulsante | Trigger valve housing |
| 53.41 | Pistone servovalvola | Valve piston |
| 54.41 | Pulsante | Trigger valve |
| 55.41 | Raccordo pulsante | Bush |
| 64.20 | Carter | Hold Down |
| 64.21.1 | Carter Mobile | Movable Hold Down |
| 71.23 | Reggicaricatore | Support |
| 73.00 | Perno | Pin |
| 74.04 | Staffa | Stirrup |
| 76.05 | Perno | Pin |
| 76.26 | Perno carter | Pin |
| 77.24 | Guida sicura | Safety guide |
| 80.09 | Grilletto chiusura | Trigger |
| 81.26 | Pistoncino | Piston |
| 90.22 | Molla | Spring |
| 91.05 | Molla | Spring |
| 91.73 | Molla | Spring |
| 92.01X | Molla | Spring |
| 93.07 | Molla | Spring |
| 21.20.90 | Battente | Driver |
| 50.23.90 | Caricatore | Magazine |
| 60.23.90 | Carrello | Slider |
| 71.23.90 | Spingipunto | Pusher |
| 82.20.40 | Controtestina | Nose |
| 90.23.90 | Testina | Nose plate |
| D01 | Boccetta olio | Oiler |

90.25 CLT-3

cod. 12370520-3

Guarnizioni - O-Rings - Joints toriques - Junta - Δακτύλιος στεγανοποίησης - Vedantes - O-ringen - Contalar - O-ringar

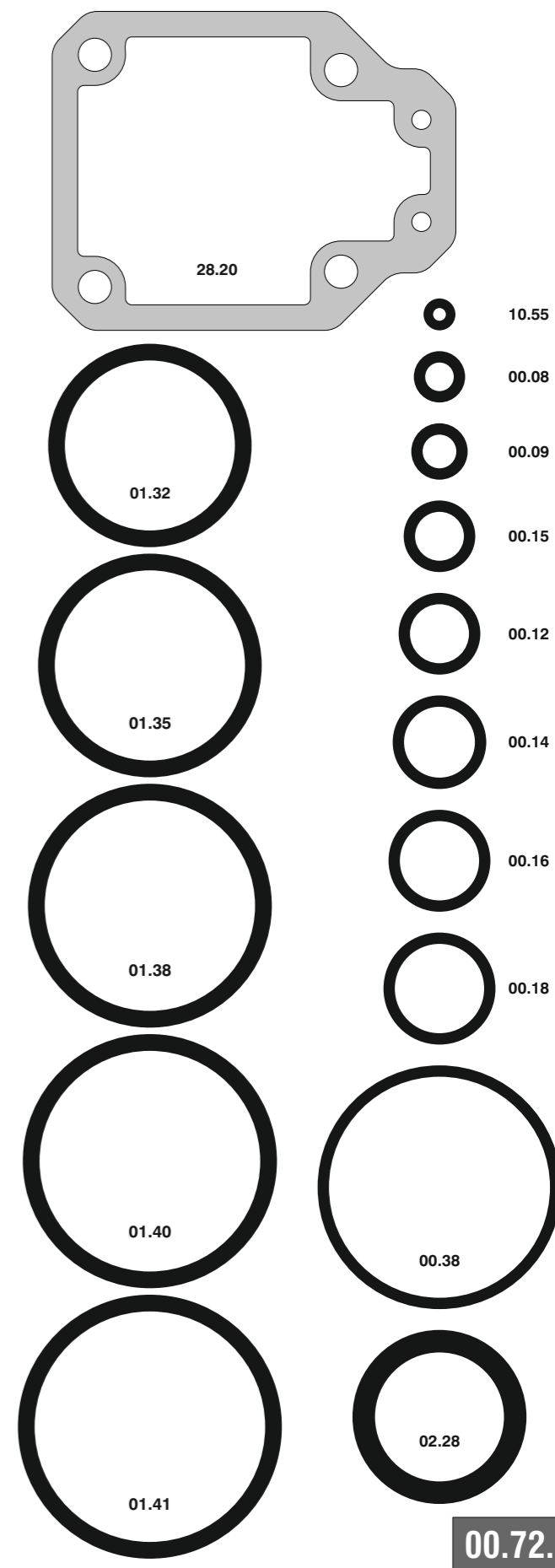

Indice di modifica
Upgrade number

3