

B12.450 FQ

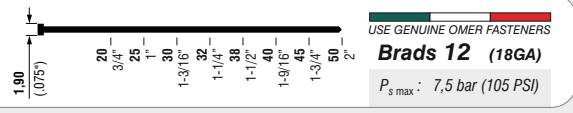

3ETB12450FQ



3ETCE

WARNING
1. Read and understand tool labels and manual.
2. Operators and others in the work area MUST wear safety glasses with side shields.
3. Keep fingers AWAY from the trigger when not driving fasteners to avoid accidental firing.
4. Choice of trigger systems is important. Check manual for triggering options.
5. NEVER point tool at your self or others in work area.
6. NEVER use oxygen or other bottled gasses. Explosion may occur.

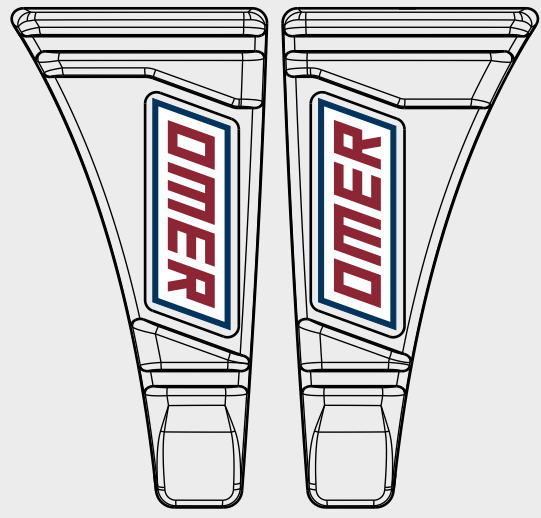

3ET99

3ET95

2007042L

2007042R

Azionamento sequenziale Completo
Full sequential actuation

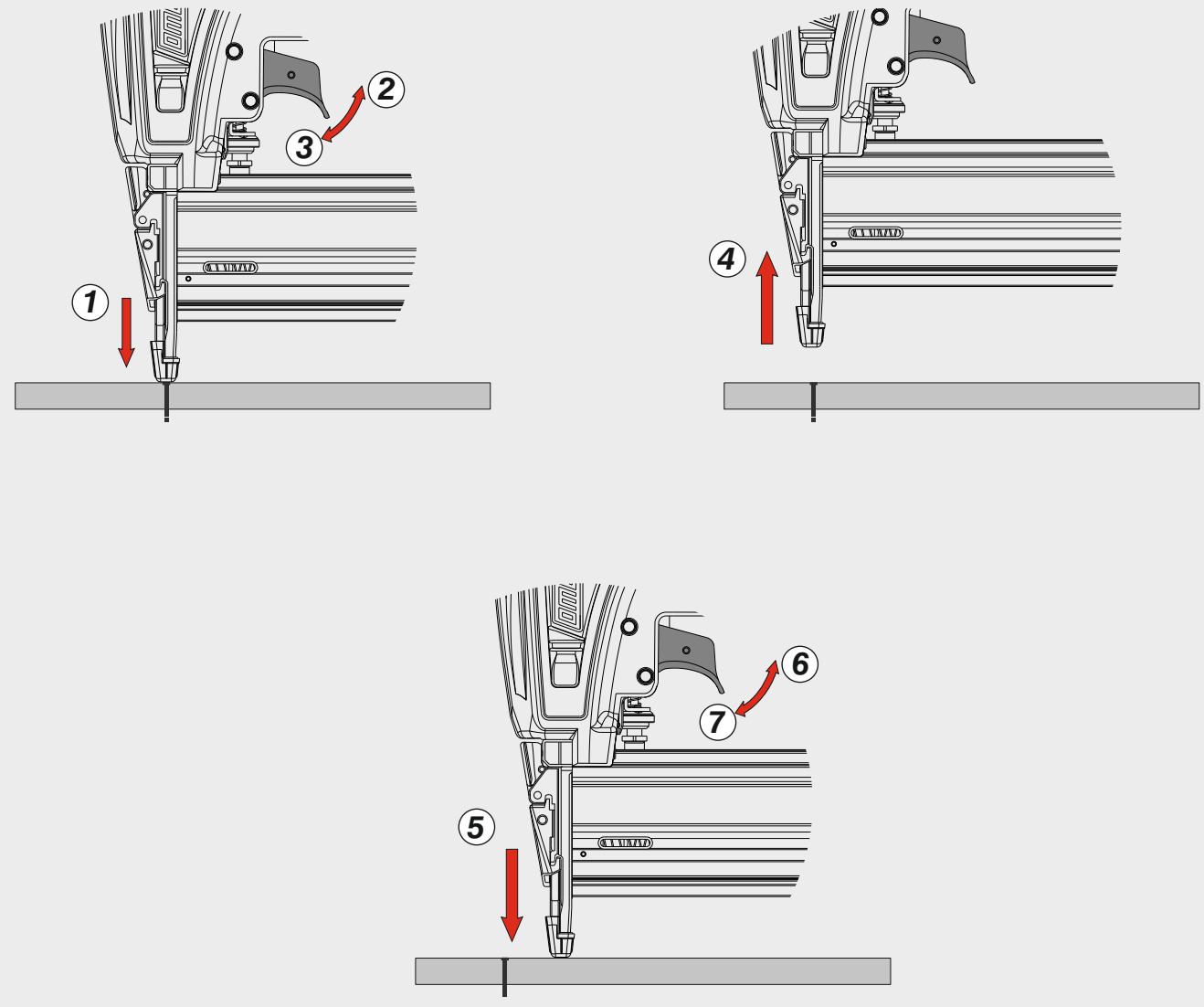

Manuale d'uso, manutenzione e parti di ricambio	Parte 2
Manual for use, maintenance and spare parts	Part 2
Bedienungs- und Wartungshandbuch sowie Ersatzteilliste	Teil 2
Mode d'emploi, de maintenance et pièces de rechange	Partie 2
Manual de uso, mantenimiento y recambios	Part 2
Εγχειρίδιο χρήσης, συντήρησης και ανταλλακτικών	Μέρος 2
Manual de uso, manutenção e peças sobresselentes	Parte 2
Handleiding voor gebruik, onderhoud en wisselstukken	Deel 2
Kullanım, bakım ve yedek parça kılavuzu	Kısım 2
Användar-, underhålls- och reservdelshandbok	Del 2



B12.450 FQ



cod. 1441200FQ

Dati tecnici Technical data Technische Daten Tekniska data	Caractéristiques techniques Datos técnicos Τεχνικά χαρακτηριστικά	Dados técnicos Technische gegevens Teknik veriler		
Misure impiegabili Lengths Verwendbare Nagellänge Dimensioner som kan användas	Dimensions utiles Medidas de longitud Μήκος Αναλωσίμου	Medidas utilizáveis Toepasbare afmetingen Boy	mm inch	20÷50 3/4"÷2"
Capacità caricatore n° punti Magazine capacity Magazinkapazität Nägel Magasinkapacitet Antal punkter	Capacité chargeur n° de points Capacidad cargador n° puntos Δυνατότητα γεμιστέρα	Capacidade carregador n° pontos Capaciteit magazijn in aantal spijkers Dergi kapasitesi		105
Pressione d'esercizio Operating pressure Betriebsdruck Drifttryck	Pression d'exercice Presión de servicio Πίεση λειτουργίας	Pressão de serviço Werkdruk Çalışma basıncı	bar psi	5÷7,5 70÷105
Consumo aria Air consumption Luftverbrauch Luftförbrukning	Consommation d'air Consumo aire Κατανάλωση αέρα	Consumo ar Luchtverbruik Hava tüketimi	lt/colpo ft³/cycle	0,50 0,0176
Peso Weight Gewicht Vikt	Poids Peso Βάρος	Peso Gewicht Ağırlık	kg lbs	1,34 2,95
Dimensioni Dimensions Abmessungen Dimensioner (AxBxH)	Dimensions Dimensiones Διαστάσεις	Dimensões Afmetingen Boyutlar	mm inch	235x64x247 9-1/4"x2-1/2"x9-3/4" (LxWxH)
EN 12549 :2009 EN ISO 4871 :2009 Pressione sonora in pos. operatore Sound pressure in operator's position Schalldruck am Arbeitsplatz Ljudtryck på operatörsplatsen	Pression sonore poste Opérateur Presión sonora en la pos. del operador Ηχητική πίεση στη θέση του χειριστή	Pressão sonora na posição Operador Geluidsdruk op de werkplaats Operatör pozisyonunda ses basıncı	dB(A)	86 (K= 4 dB)
EN 12549 :2009 EN ISO 3746 :2011 EN ISO 4871 :2009 Potenza sonora emessa Sound power emitted Emitierte Schalleistung Avgiven ljudeffekt	Puissance sonore émise Potencia sonora emitida Εκπεμπόμενη ηχητική ισχύς	Potência sonora emitida Geëmitteerd geluidsvermogen Çıkan ses gücü (ses desibel)	dB(A)	94 (K= 4 dB)
CEN ISO/TS 8662-11 :2006 EN ISO 5349-2 :2004 EN 12096 :1999 Emissione vibratoria sull'impugnatura Vibratory emissions on handle Vibrationsemission am Griff Vibrationsemission på handtaget	Émission vibratoire sur la prise en main Emisión de vibraciones en la empuñadura Εκπεμπόμενες δονήσεις στη λαβή	Emissão vibratória na empunhadura Trillingsemissie op de handgreep Tutamak üzerinde vibrasyon emisyonları	m/s²	3,10 (K= 2 m/s ²)

Tipo di punto
Type of fastener
Befestigungsmittel
Type de rivet
Tipo de punto
Τύπος αναλωσίμου
Tipo de agrafa
Type nietjes
Zimba ve çivi tipleri
Typ av stygn

Brads 12

1,00x1,25

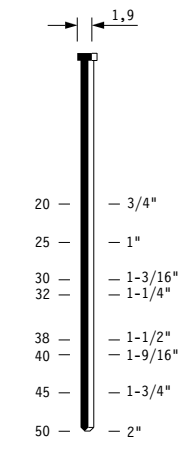

Head width: .075"
Gauge: 18

1441200FQ_B12450FQ_4_rev22_15/05/2024_DV

Parti di ricambio - Spare parts - Ersatzteile - Pièces de rechange - Recambios
Ανταλλακτικά - Partes sobresselentes - Wisselstukken - Yedek parçalar - Reservdelar

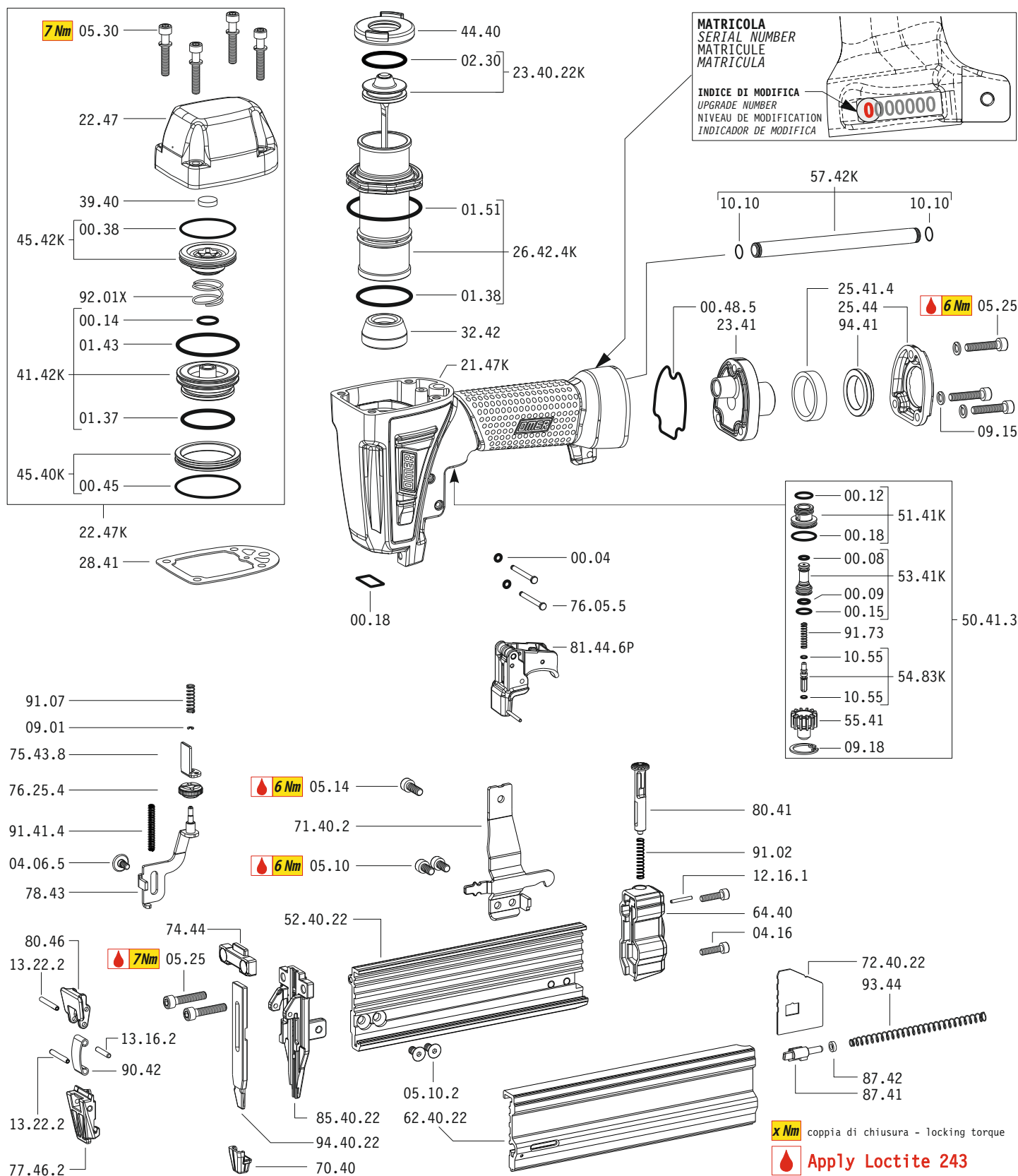

Dotazioni - Equipment - Ausstattung - Outillage - Dotaciones - Εξοπλισμός
Dotações - Uitrusting - Donanimlar - Utrustning

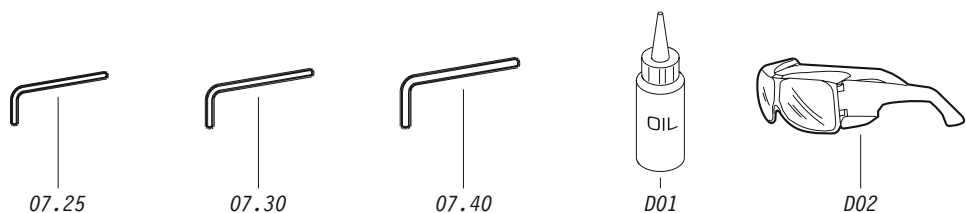

B12.450 FQ

cod. 1441200FQ

Parti di ricambio - Spare parts - Ersatzteile - Pièces de rechange - Recambios
Ανταλλακτικά - Partes sobresselentes - Wisselstukken - Yedek parçalar - Reservdelar

Cod.	Descrizione	Description
00.04	O-Ring	O-Ring
00.08	O-Ring	O-Ring
00.09	O-Ring	O-Ring
00.12	O-Ring	O-Ring
00.14	O-Ring	O-Ring
00.15	O-Ring	O-Ring
00.18	O-Ring	O-Ring
00.38	O-Ring	O-Ring
00.45	O-Ring	O-Ring
00.48.5	Guarnizione	Gasket
01.37	O-Ring	O-Ring
01.38	O-Ring	O-Ring
01.43	O-Ring	O-Ring
01.51	O-Ring	O-Ring
02.30	O-Ring	O-Ring
04.06.5	Vite	Screw
04.16	Vite	Screw
05.10	Vite	Screw
05.10.2	Vite	Screw
05.14	Vite	Screw
05.25	Vite	Screw
05.30	Vite	Screw
07.25	Chiave esagonale	Hex. bar wrench
07.30	Chiave esagonale	Hex. bar wrench
07.40	Chiave esagonale	Hex. bar wrench
09.01	Anello elastico	Elastic ring
09.15	Rondella	Washer
09.18	Anello elastico	Elastic ring
10.10	O-Ring	O-Ring
10.55	O-Ring	O-Ring
12.16.1	Spina	Pin
13.16.2	Spina	Pin
13.22.2	Spina	Pin
21.47K	Corpo	Body
22.47K	Testa completa	Head unit
22.47	Testa	Head
23.41	Fondello	Case back
25.41.4	Silenziatore	Silencer
25.44	Deflettore	Exhaust deflector
26.42.4K	Cilindro	Cylinder
28.41	Guarnizione testa	Head gasket
32.42	Ammortizzatore	Bumper
39.40	Guarnizione	Seal
41.42K	Valvola	Valve
44.40	Guarnizione	Gasket
45.40K	Anello valvola	Ring
45.42K	Anello testa	Ring
50.41.3	Pulsante completo	Trigger valve ass'y
51.41K	Boccola pulsante	Trigger valve housing
53.41K	Pistone servovalvola	Valve piston
54.83K	Pulsante	Trigger valve
55.41	Raccordo pulsante	Bush
57.42K	Tubo scarico	Exhaust pipe
64.40	Fondello	Case back
70.40	Puntale	Tip
71.40.2	Reggicaricatore	Support
74.44	Staffa testina	Head bracket
75.43.8	Rinvio sicura	Referral safety
76.05.5	Perno	Pin
76.25.4	Regolatore	Controller
77.46.2	Guida testina	Head guide
78.43	Sicura	Safety
80.41	Grilletto chiusura	Trigger
80.46	Grilletto testina	Trigger
81.44.6P	Grilletto FQ	FQ Trigger
87.41	Portamolla	Spring holder
87.42	Segnalatore	Tracker
90.42	Molla	Spring
91.02	Molla	Spring
91.07	Molla	Spring
91.41.4	Molla	Spring
91.73	Molla	Spring
92.01	Molla	Spring
93.44	Molla	Spring
94.41	Boccola	Bushing
23.40.22K	Battente	Driver
52.40.22	Caricatore	Magazine
62.40.22	Carrello	Slider
72.40.22	Spingipunto	Pusher
85.40.22	Controtestina	Nose
94.40.22	Testina	Nose plate
D01	Bocchetta olio	Oiler
D02	Occhiali protettivi	Protective goggles

Guarnizioni - O-Rings - Dichtungen - Joints toriques - Δακτύλιος στεγανοποίησης - Vedantes - O-ringen - Contalar - O-ringar

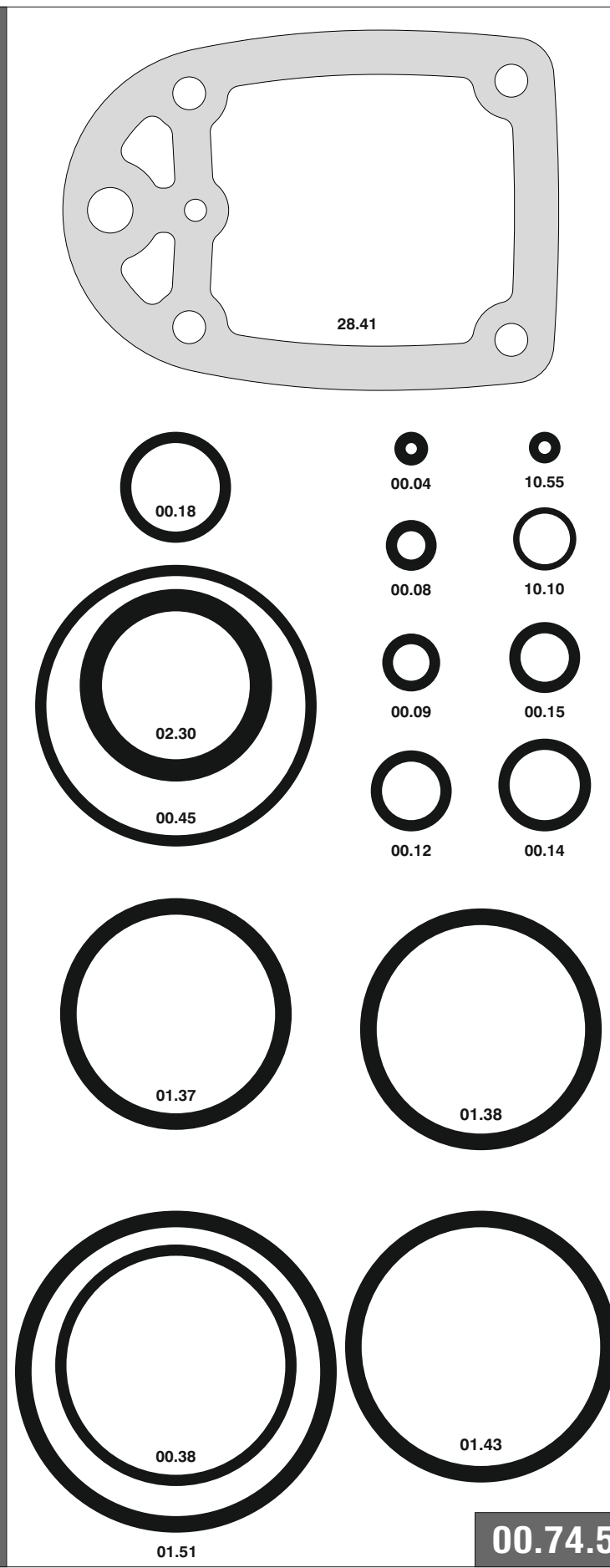

B12.450 FQ

cod. 1441200FQ

Indice di modifica
Upgrade number

4

Disinceppamento - Jam clearing - Staubeseitigung - Décoincement - Desatascamiento - Απεμπλοκή
Desencravamento - Deblokkering bij vastlopen - Sikişma giderme - Rensning av igensättningar

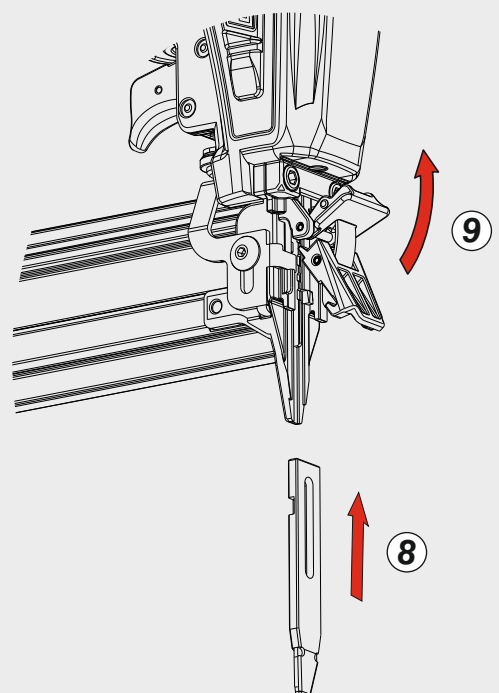
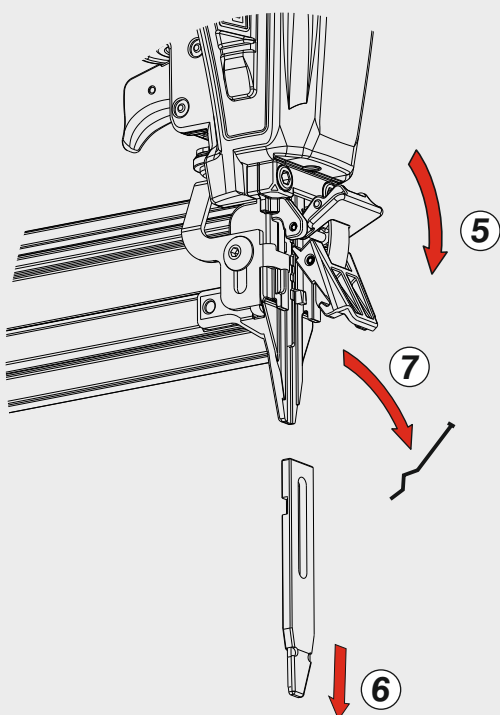
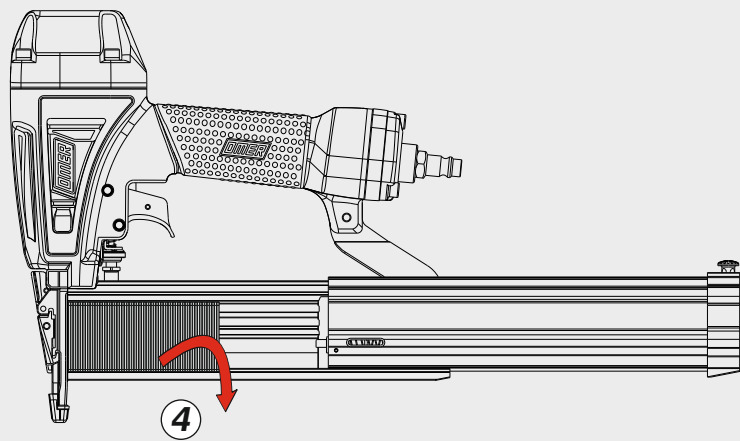
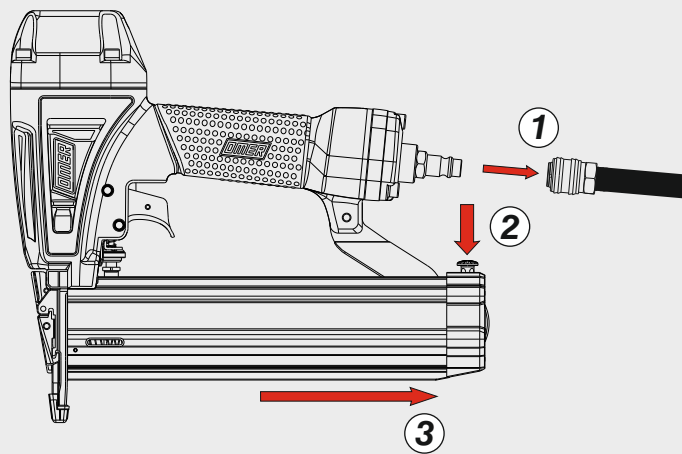

Caricamento dal fianco

Side load magazine

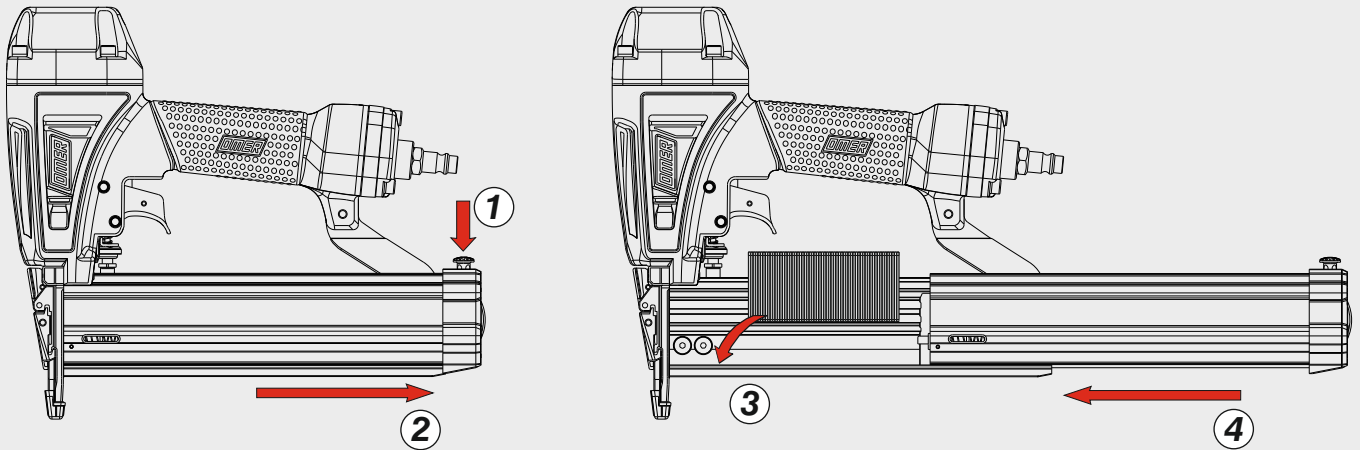

Regolazione di profondità - Depth adjustment - Tiefeneinstellung - Réglage des dimensions - Réglage des dimensions
Ρύθμιση βάθους - Regulação de profundidade - Diepte afstelling - Derinlik ayarı - Djupjustering

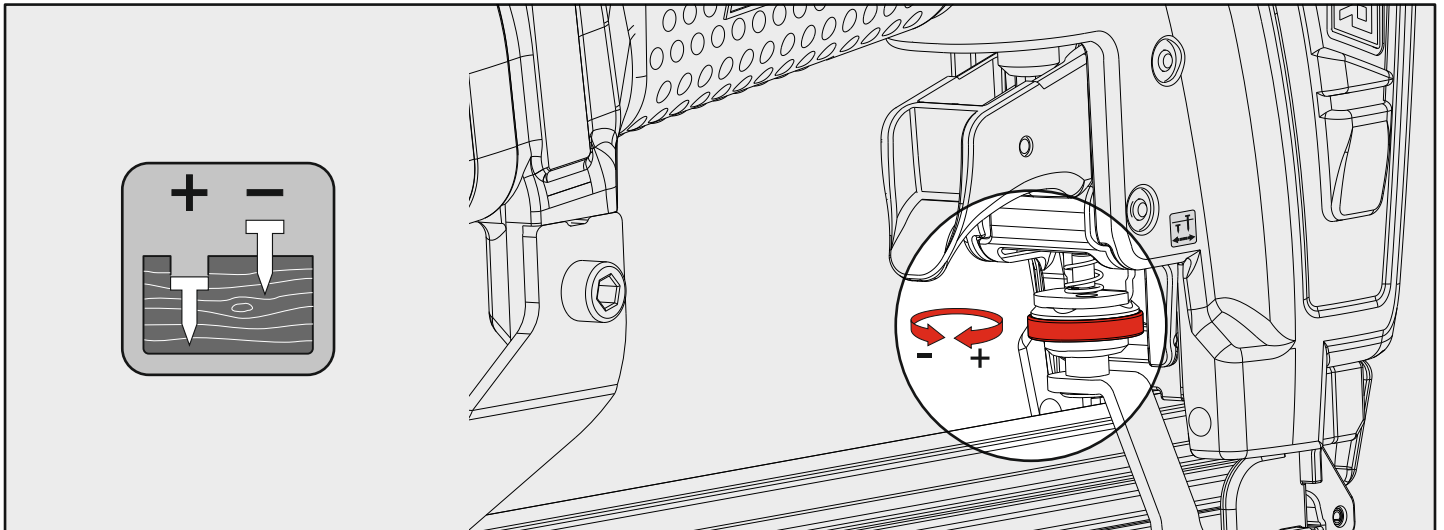

Caratteristiche - Features - Merkmale - Caractéristiques - Características - Χαρακτηριστικά
Características - Kenmerken - Özellikler - Funktionen

Segnalatore punti rimanenti

Fastener quantity indicator

