

M2.438 B

USE GENUINE OMER FASTENERS
STAPLES M2 (16GA)

15 - 5/8" Crown: .421" 1,40x1,60
40 - 1-9/16" P_s max: 7,5 bar (105 PSI)

3ETM2438B

omer s.p.a. CE UK CA
Via Foresto, 42 - 31058 SUSEGANA (TV) ITALY 2023

3ETCE

WARNING
1. Read and understand tool labels and manual.
2. Failure to follow warnings could result in DEATH or SERIOUS INJURY.
3. Operators and others in the work area MUST wear safety glasses with side shields.
4. Keep fingers AWAY from the trigger when not driving fasteners to avoid accidental firing.
5. Choice of trigger systems is important. Check manual for triggering options.
6. NEVER point tool at your self or others in work area.
7. NEVER use oxygen or other bottled gasses. Explosion may occur.



3ET99

3ETS1

3ET95

2007042L

2007042R

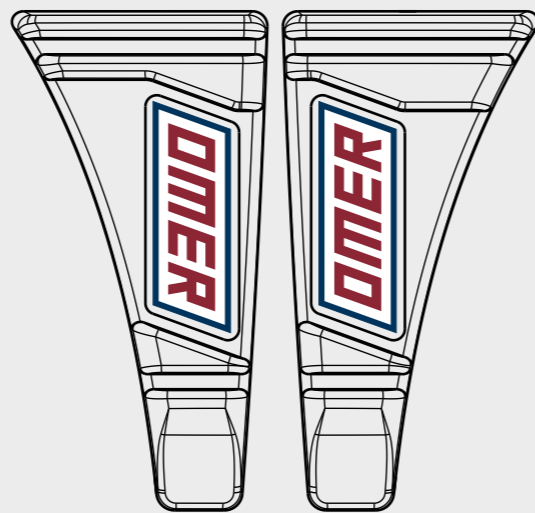

Azionamento - Actuation - Auslösung - Actionnement - Accionamiento - Ενεργοποίηση
Acionamento - Activering - Çalıştırma - Aktivierung

Azionamento a contatto

Contact actuation



81.44

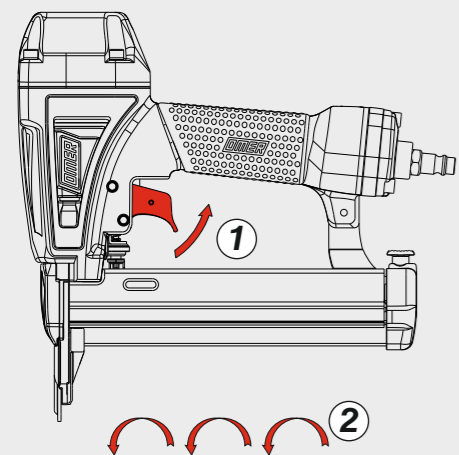

Oppure - Or

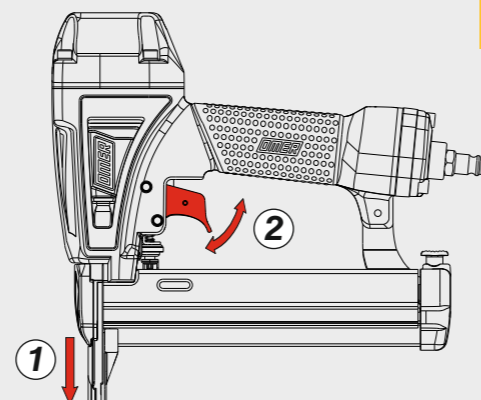

Azionamento sequenziale singolo

Single sequential actuation



81.44.1

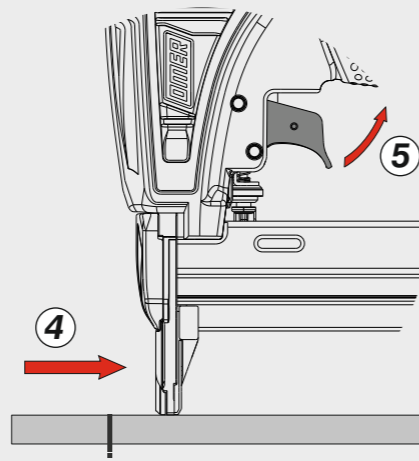
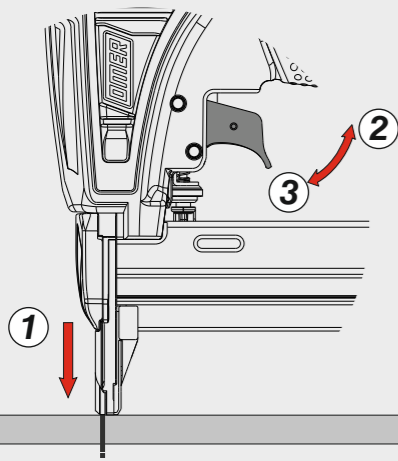

Manuale d'uso, manutenzione e parti di ricambio

Manual for use, maintenance and spare parts

Bedienungs- und Wartungshandbuch sowie Ersatzteilleiste

Mode d'emploi, de maintenance et pièces de rechange

Manual de uso, mantenimiento y recambios

Εγχειρίδιο χρήσης, συντήρησης και ανταλλακτικών

Manual de uso, manutenção e peças sobresselentes

Handleiding voor gebruik, onderhoud en wisselstukken

Kullanım, bakım ve yedek parça kılavuzu

Användar-, underhålls- och reservdelshandbok

Parte 2

Part 2

Teil 2

Partie 2

Part 2

Μέρος 2

Parte 2

Deel 2

Kısım 2

Del 2



M2.438 B

cod. 1448230



Warning: Please read the instructions and warnings for this tool carefully before use. Failure to do so could lead to serious injury.

Dati tecnici

Technical data
Technische Daten
Tekniska data

Caractéristiques techniques
Datos técnicos
Τεχνικά χαρακτηριστικά

Dados técnicos
Technische gegevens
Teknik veriler

Misure impiegabili

Lengths
Verwendbare Nagellänge
Dimensioner som kan användas

Dimensions utiles
Medidas de longitud
Μήκος Αναλωσίμου

Medidas utilizáveis
Toepasbare afmetingen
Boy

15 + 40 mm
5/8" + 1-9/16" inch

Capacità caricatore n° punti
Magazine capacity
Magazinkapazität: Nägel
Magasinkapacitet: Antal punkter

Capacité chargeur n° de points
Capacidad cargador n° puntos
Δυνατότητα γεμιστέρα

Capacidade carregador n° pontos
Capaciteit magazijn in aantal spijkers
Dergi kapasitesi

105

Pressione d'esercizio
Operating pressure
Betriebsdruck
Drifttryck

Pression d'exercice
Presión de servicio
Πίεση λειτουργίας

Pressão de serviço
Werkdruk
Çalışma basıncı

5 + 7,5 bar
70 + 105 psi

Consumo aria
Air consumption
Luftverbrauch
Luftförbrukning

Consommation d'air
Consumo aire
Κατανάλωση αέρα

Consumo ar
Luchtverbruik
Hava tüketimi

0,50 lt/colpo
0,0176 ft³/cycle

Peso
Weight
Gewicht
Vikt

Poids
Peso
Βάρος

Peso
Gewicht
Ağırlık

1,47 kg
3,24 lbs

Dimensioni
Dimensions
Abmessungen
Dimensioner (AxBxH)

Dimensions
Dimensiones
Διαστάσεις

Dimensões
Afmetingen
Boyutlar

mm
inch
238x64x242
9-3/8"x2-1/2"x9-1/2"
(LxWxH)

EN 12549 :2009 EN ISO 4871 :2009

Pressione sonora in pos. operatore
Sound pressure in operator's position
Schalldruck am Arbeitsplatz
Ljudtryck på operatörsplatsen

Pression sonore poste Opérateur
Presión sonora en la pos. del operador
Ηχητική πίεση στη θέση του χειριστή
Operatör pozisyonunda ses basıncı

Pressão sonora na posição Operador
Geluidsdruk op de werkplaats
Operatör pozisyonunda ses basıncı

86 dB(A)

(K = 4 dB)

EN 12549 :2009 EN ISO 3746 :2011 EN ISO 4871 :2009

Potenza sonora emessa
Sound power emitted
Emitierte Schalleistung
Avgiven ljudeffekt

Puissance sonore émise
Potencia sonora emitida
Εκπεμπόμενη ηχητική ισχύς

Potência sonora emitida
Geëmitteerd geluidsvermogen
Çıkan ses gücü (ses desibeli)

94 dB(A)

(K = 4 dB)

CEN ISO/TS 8662-11 :2006 EN ISO 5349-2 :2004 EN 12096 :1999

Emissione vibratoria sull'impugnatura
Vibratory emissions on handle
Vibrationsemission am Griff
Vibrationsemission på handtaget

Émission vibratoire sur la prise en main
Emisión de vibraciones en la empuñadura
Εκπεμπόμενες δονήσεις στη λαβή
Tutamak üzerindeki vibrasyon emisyonları

Emissão vibratória na empunhadura
Trillingsemissie op de handgreep
Tutamak üzerindeki vibrasyon emisyonları

3,10 m/s²

(K = 2 m/s²)

Tipo di punto
Type of fastener
Befestigungsmittel
Type de rivet
Tipo de punto
Τύπος αναλωσίμου
Tipo de agrafa
Type nietjes
Zimba ve çivi tipleri
Typ av stygn

M2

1,40x1,60

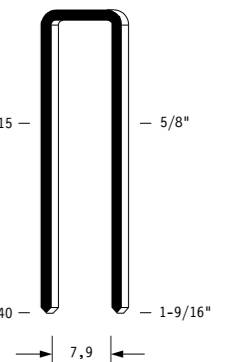

Crown: .421" (7/16")
Gauge: 16

Parti di ricambio - Spare parts - Ersatzteile - Pièces de rechange - Recambios
Ανταλλακτικά - Partes sobresselentes - Wisselstukken - Yedek parçalar - Reservdelar

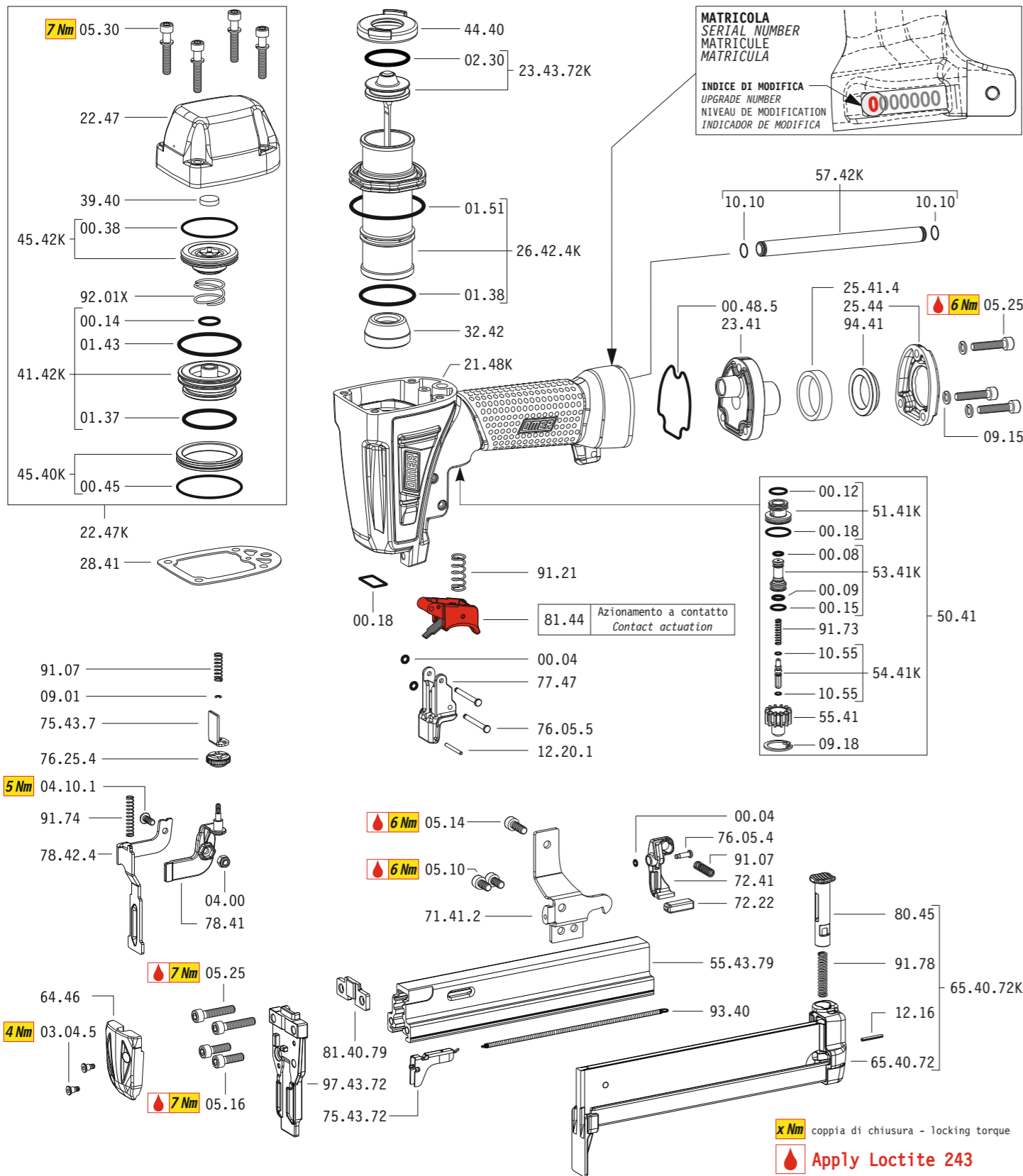

Dotazioni - Equipment - Ausstattung - Outillage - Dotaciones - Εξοπλισμός
Dotações - Uitrusting - Donanimlar - Utrustning

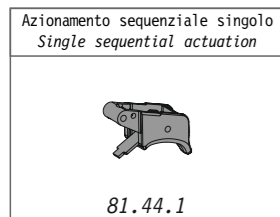

M2.438 B

cod. 1448230

Parti di ricambio - Spare parts - Ersatzteile - Pièces de rechange - Recambios
Ανταλλακτικά - Partes sobresselentes - Wisselstukken - Yedek parçalar - Reservdelar

Cod.	Descrizione	Description
00.04	O-Ring	O-Ring
00.08	O-Ring	O-Ring
00.09	O-Ring	O-Ring
00.12	O-Ring	O-Ring
00.14	O-Ring	O-Ring
00.15	O-Ring	O-Ring
00.18	O-Ring	O-Ring
00.38	O-Ring	O-Ring
00.45	O-Ring	O-Ring
00.48.5	Guarnizione	Gasket
01.37	O-Ring	O-Ring
01.38	O-Ring	O-Ring
01.43	O-Ring	O-Ring
01.51	O-Ring	O-Ring
02.30	O-Ring	O-Ring
03.04.5	Vite	Screw
04.00	Dado	Nut
04.10.1	Vite	Screw
05.10	Vite	Screw
05.14	Vite	Screw
05.16	Vite	Screw
05.25	Vite	Screw
05.30	Vite	Screw
07.25	Chiave esagonale	Hex. bar wrench
07.30	Chiave esagonale	Hex. bar wrench
07.40	Chiave esagonale	Hex. bar wrench
09.01	Anello elastico	Elastic ring
09.15	Rondella	Washer
09.18	Anello elastico	Elastic ring
10.10	O-Ring	O-Ring
10.55	O-Ring	O-Ring
12.16	Spina	Pin
12.20.1	Spina	Pin
21.48K	Corpo	Body
22.47K	Testa completa	Head unit
22.47	Testa	Head
23.41	Fondello	Case back
25.41.4	Silenziatore	Silencer
25.44	Deflettore	Exhaust deflector
26.42.4K	Cilindro	Cylinder
28.41	Guarnizione	Gasket
32.42	Ammortizzatore	Bumper
39.40	Guarnizione	Gasket
41.42K	Valvola	Valve
44.40	Guarnizione	Gasket
45.40K	Anello valvola	Ring
45.42K	Anello testa	Ring
50.41	Pulsante completo	Trigger valve assy
51.41K	Boccola	Valve housing
53.41K	Pistone servovalvola	Valve piston
54.41K	Pulsante	Trigger valve
55.41	Raccordo pulsante	Bush
57.42K	Tubo di scarico	Exhaust pipe
64.46	Carter	Hold down
71.41.2	Reggicaricatore	Support
72.22	Fermo carrello	Slider stop
72.41	Fermo carrello	Slider stop
75.43.7	Rinvio sicura	Referral safety
76.05.4	Perno	Pin
76.05.5	Perno	Pin
76.25.4	Regolatore	Controller
77.47	Guida sicura	Safety guide
78.41	Sicura	Safety
78.42.4	Sicura	Safety
80.45	Grilletto	Trigger
81.44	Grilletto comando	Trigger
81.44.1	Grilletto comando	Trigger
91.07	Molla	Spring
91.21	Molla	Spring
91.73	Molla	Spring
91.74	Molla	Spring
91.78	Molla	Spring
92.01X	Molla	Spring
93.40	Molla	Spring
94.41	Boccola	Bushing
23.43.72K	Battente	Driver
55.43.79	Caricatore	Magazine
65.40.72K	Carrello completo	Slider unit
65.40.72	Carrello	Slider
75.43.72	Spingipunto	Pusher
81.40.79	Controtestina	Nose
97.43.72	Testina	Nose plate
D01	Bocchetta olio	Oiler
D02	Occhiali protettivi	Protective goggles

Guarnizioni - O-Rings - Dichtungen - Joints toriques - Junta - Δακτύλιος στεγανοποίησης - Vedantes - O-ringen - Contalar - O-ringar

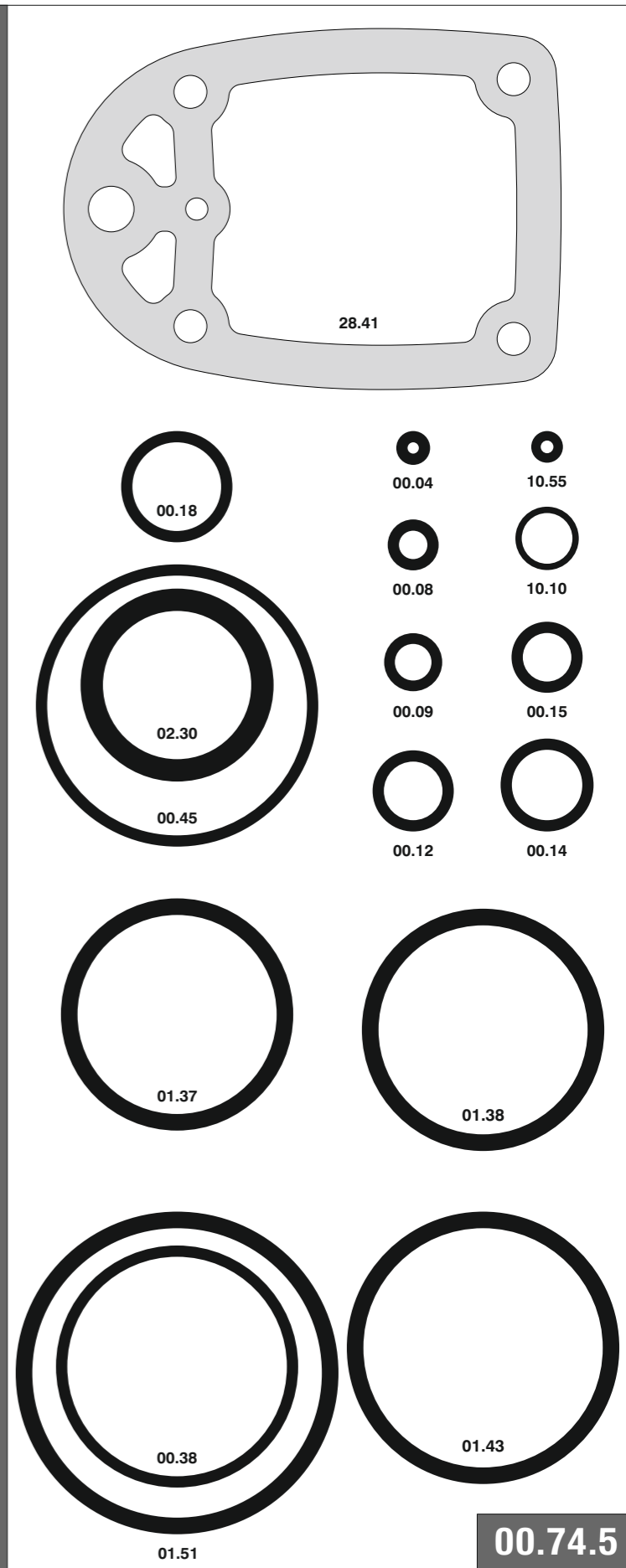

M2.438 B

cod. 1448230

Indice di modifica **4**
Upgrade number

Caricamento da sotto
Bottom load magazine

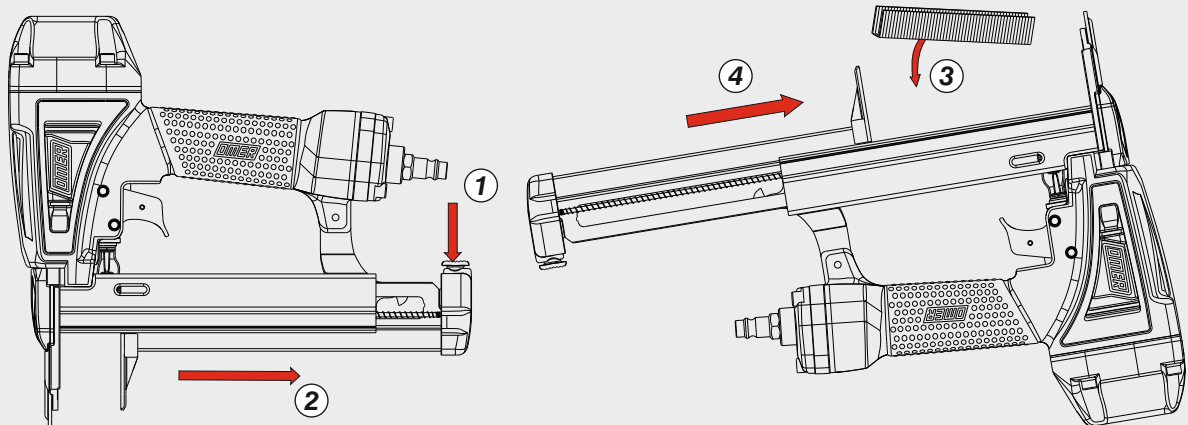

Disinceppamento - Jam clearing - Staubeseitigung - Décoincement - Desatascamiento - Απεμπλοκή
Desencravamento - Deblokkering bij vastlopen - Sıkışma giderme - Rensning av igensättningar

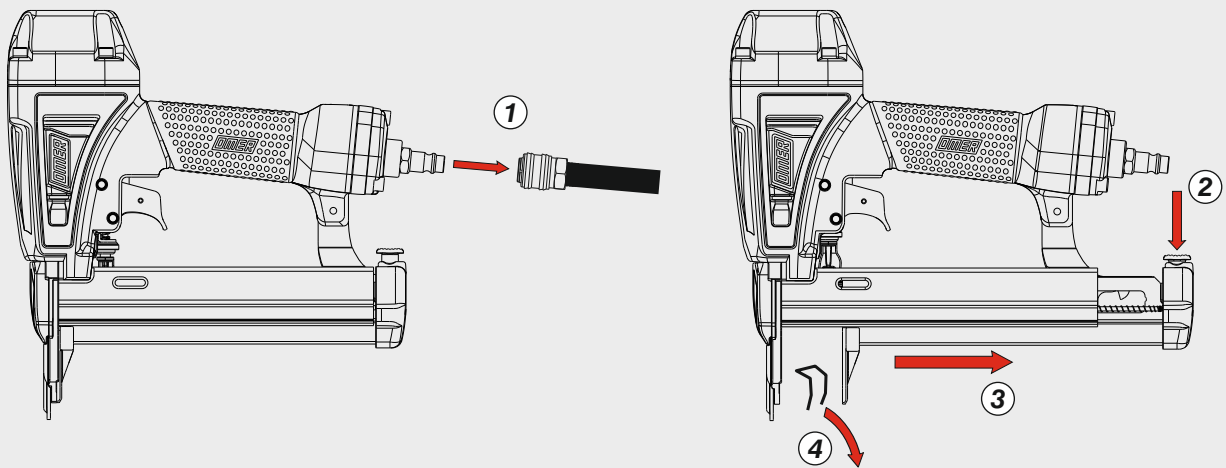

Estrazione carrello
Slider extraction

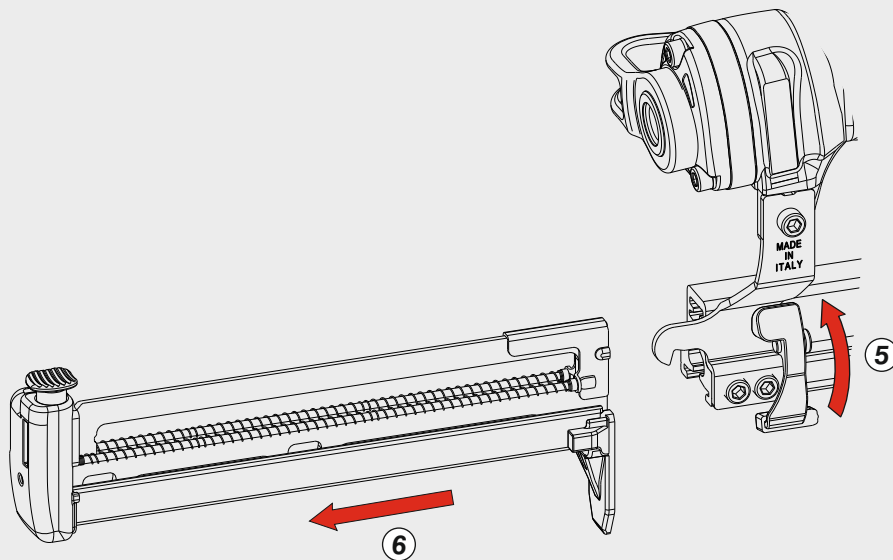

Regolazione di profondità - Depth adjustment - Tiefeneinstellung - Réglage des dimensions - Réglage des dimensions
Ρύθμιση βάθους - Regulação de profundidade - Diepte afstelling - Derinlik ayarı - Djupjustering

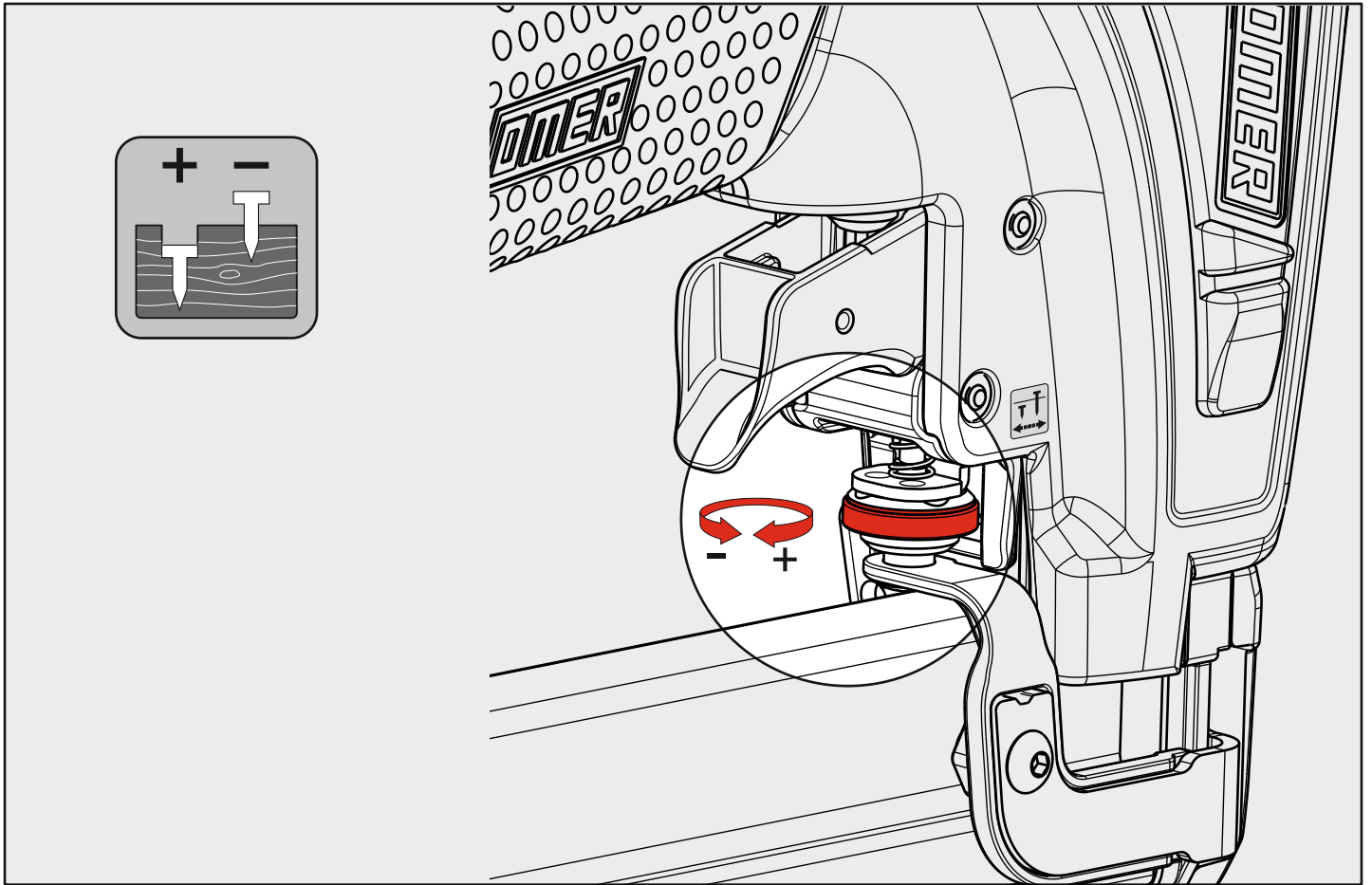

Caratteristiche - Features - Merkmale - Caractéristiques - Características - Χαρακτηριστικά
Características - Kenmerken - Özellikler - Funktionen

Segnalatore punti rimanenti

Fastener quantity indicator

