

Caratteristiche - Features - Merkmale - Caractéristiques - Características - Χαρακτηριστικά - Características - Kenmerken - Özellikler

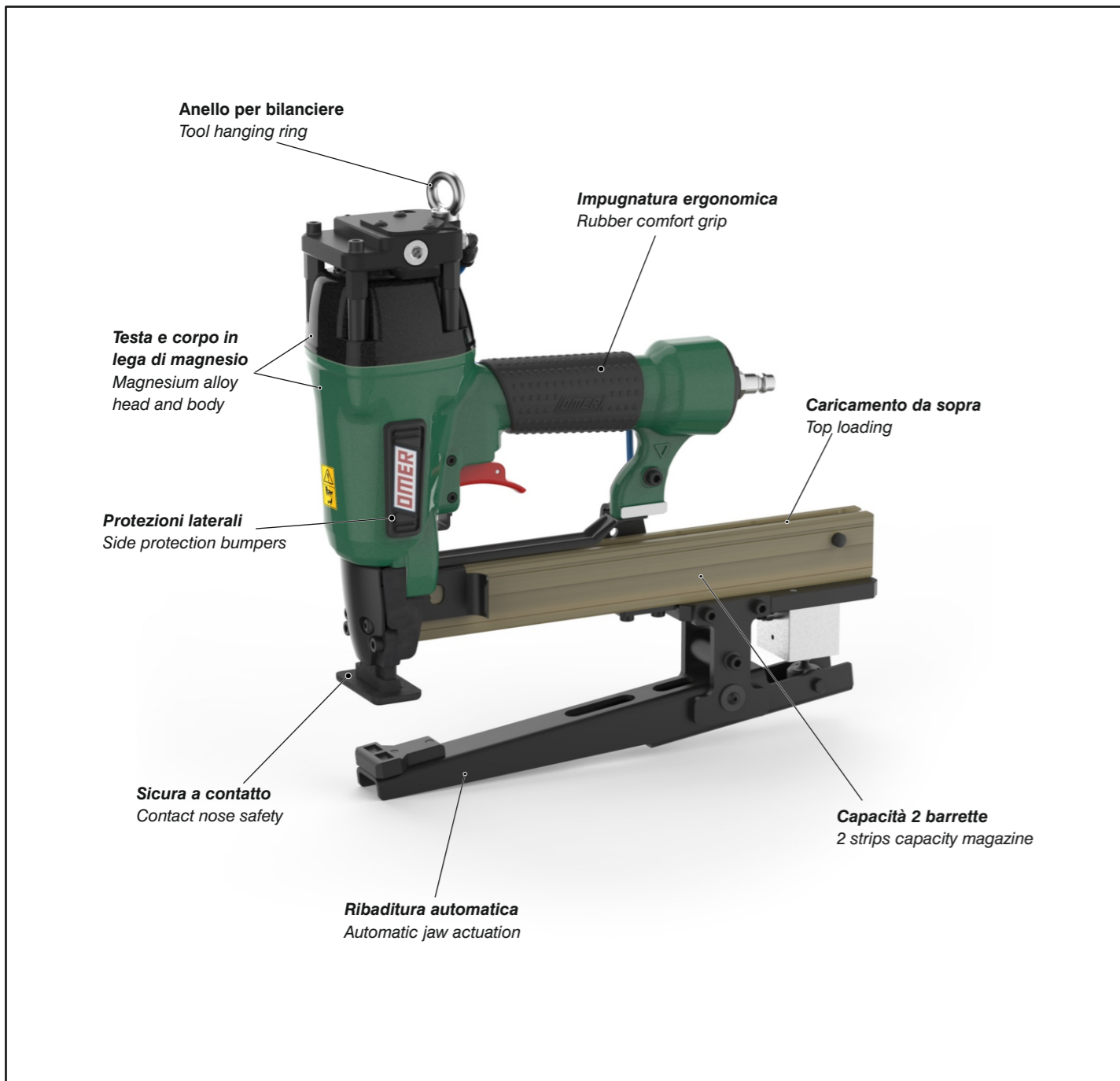

Manuale d'uso, manutenzione e parti di ricambio
Manual for use, maintenance and spare parts
Bedienungs- und Wartungshandbuch sowie Ersatzteilleiste
Mode d'emploi, de maintenance et pièces de rechange
Manual de uso, mantenimiento y recambios
Εγχειρίδιο χρήσης, συντήρησης και ανταλλακτικών
Manual de uso, manutenção e peças sobresselentes
Handleiding voor gebruik, onderhoud en wisselstukken
Kullanım, bakım ve yedek parça kılavuzu

Parte 2
Part 2
Teil 2
Partie 2
Part 2
Μέρος 2
Parte 2
Deel 2
Kısım 2



PL 590.738

cod. 1748710PL



Warning: Please read the instructions and warnings for this tool carefully before use. Failure to do so could lead to serious injury.

| Dati tecnici Technical data Technische Daten | Caractéristiques techniques Datos técnicos Τεχνικά χαρακτηριστικά | Dados técnicos Technische gegevens Teknik veriler | |
|--|---|---|---|
| Misure impiegabili mm Lengths mm Verwendbare Nagellänge mm | Dimensions utiles mm Medidas de longitud mm Μήκος Αναλωσίμου - mm | Medidas utilizáveis mm Toepasbare afmetingen mm Boy mm | 16 ÷ 38 |
| Capacità caricatore n° punti Magazine capacity Magazinkapazität Nägel | Capacité chargeur n° de points Capacidad cargador n° puntos Δωσατοτητα γεμιστρα | Capacidade carregador n° pontos Capaciteit magazijn in aantal spijkers Dergi kapasitesi | 130 |
| Pressione d'esercizio Operating pressure Betriebsdruck | Pression d'exercice Presión de servicio Πίεση λειτουργίας | Pressão de serviço Werkdruk Çalışma basıncı | 5 ÷ 7,5 bar 70 ÷ 105 psi |
| Consumo aria litri/colpo Air consumption litres/stroke Luftverbrauch Liter/Schuss | Consommation d'air litres/coup Consumo aire litros/golpe Κατανάλωση αέρα - λίτρα/βολή | Consumo ar litros/disparo Luchtverbruik liter/slag Litre/vuruş hava tüketimi | 0,75 |
| Peso kg Weight kg Gewicht kg | Poids kg Peso kg Βάρος - kg | Peso kg Gewicht in kg Ağırlık kg | 3,40 |
| Dimensioni mm Dimensions mm Abmessungen mm | Dimensions mm Dimensiones mm Διαστάσεις mm | Dimensões mm Afmetingen mm Boyutlar mm | 345x77x348 (LxWxH) |
| UNI EN 12549 :2009 UNI EN ISO 4871 :2009 Pressione sonora in pos. operatore Sound pressure in operator's position Schalldruck am Arbeitsplatz | Pression sonore poste Opérateur Presión sonora en la pos. del operador Ηχητική πίεση στη θέση του Χειριστή | Pressão sonora na posição Operador Geluidsdruk op de werkplaats Operatör pozisyonunda ses basıncı | 94 dB(A) (K= 4 dB) |
| UNI EN 12549 :2009 UNI EN ISO 3746 :2011 UNI EN ISO 4871 :2009 Potenza sonora emessa Sound power emitted Emittierte Schallleistung | Puissance sonore émise Potencia sonora emitida Εκπεμπόμενη ηχητική ισχύς | Potência sonora emitida Geëmitteerd geluidsvermogen Çıkan ses gücü (ses desibel) | 103 dB(A) (K= 4 dB) |
| UNI CEN ISO/TS 8662-11 :2006 UNI EN ISO 5349-2 :2004 UNI EN 12096 :1999 Emissione vibratoria sull'impugnatura Vibratory emissions on handle Vibrationsemission am Griff | Émission vibratoire sur la prise en main Emisión de vibraciones en la empuñadura Εκπεμπόμενες δονήσεις στη λαβή | Emissão vibratória na empunhadura Trillingsemissie op de handgreep Tutamak üzerinde vibrasyon emisyonları | 4,19 m/s² (K= 2 m/s ²) |

Tipo di punto
 Type of fastener
 Befestigungsmittel
 Type de rivet
 Tipo de punto
 Τύπος αναλωσίμου
 Tipo de agrafa
 Type nietjes
 Zimba ve çivi tipleri

590

0,85x1,80

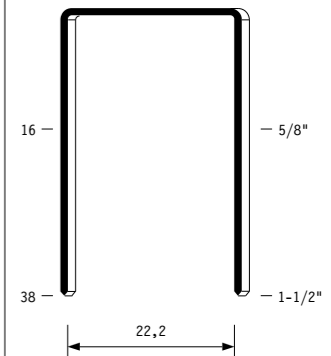

Crown: .941" (15/16")
 Gauge: 17

Parti di ricambio - Spare parts - Ersatzteile - Pièces de rechange - Recambios
Ανταλλακτικά - Partes sobresselentes - Wisselstukken - Yedek parçalar

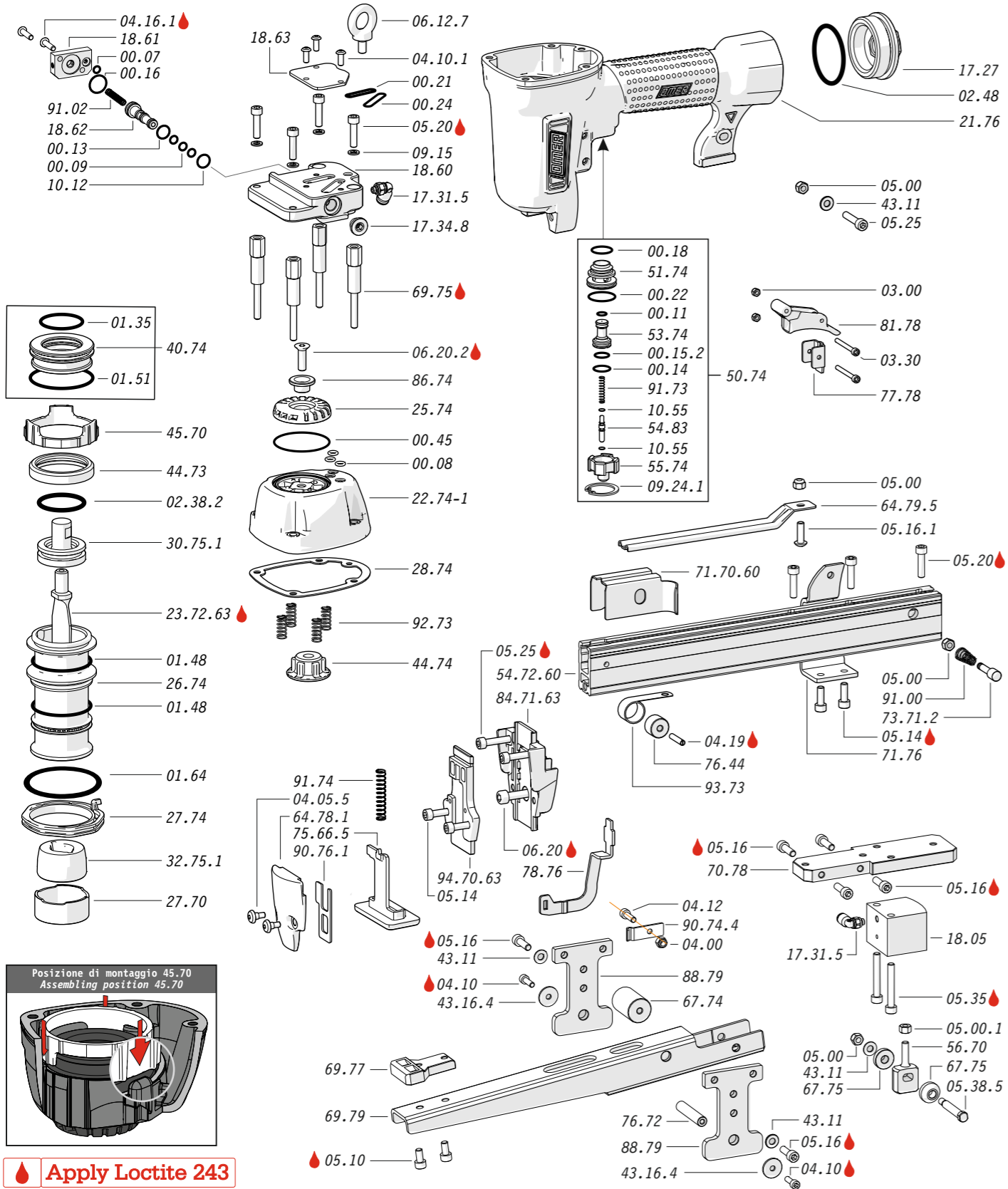

Dotazioni - Equipment - Ausstattung - Outillage - Dotaciones - Εξοπλισμός
Dotações - Uitrusting - Donanımlar

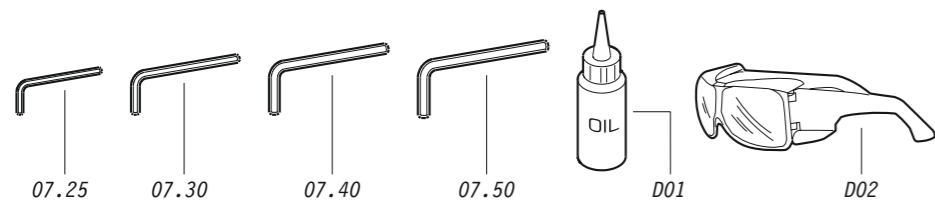

PL 590.738

cod. 1748710PL

Caricamento - Loading - Laden - Chargement - Carga - Γέμισμα - Carregamento - Laden - Yükleme

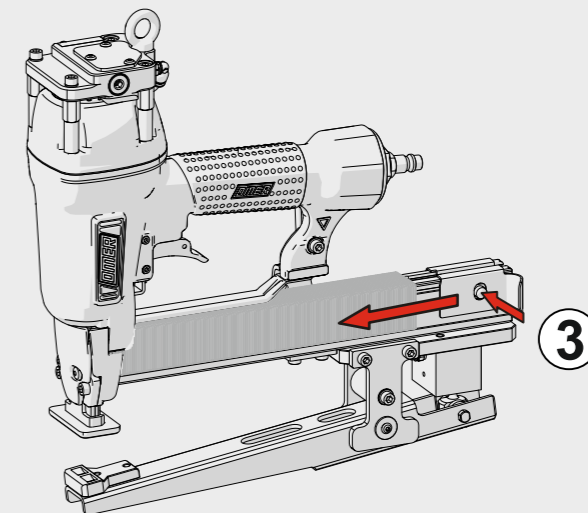
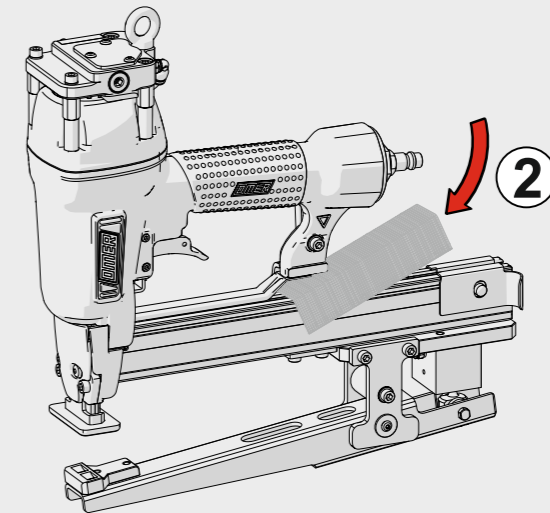
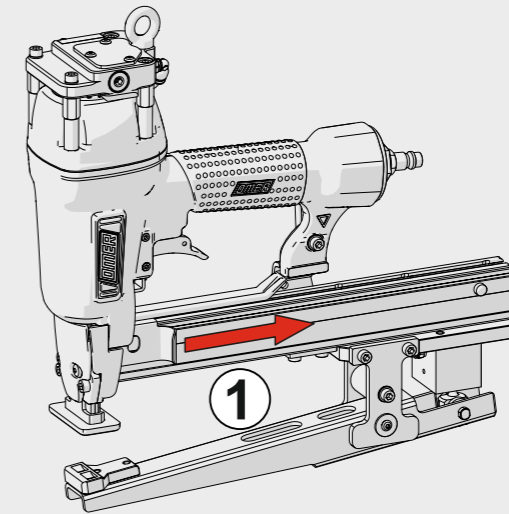

Azionamento a contatto
Contact actuation

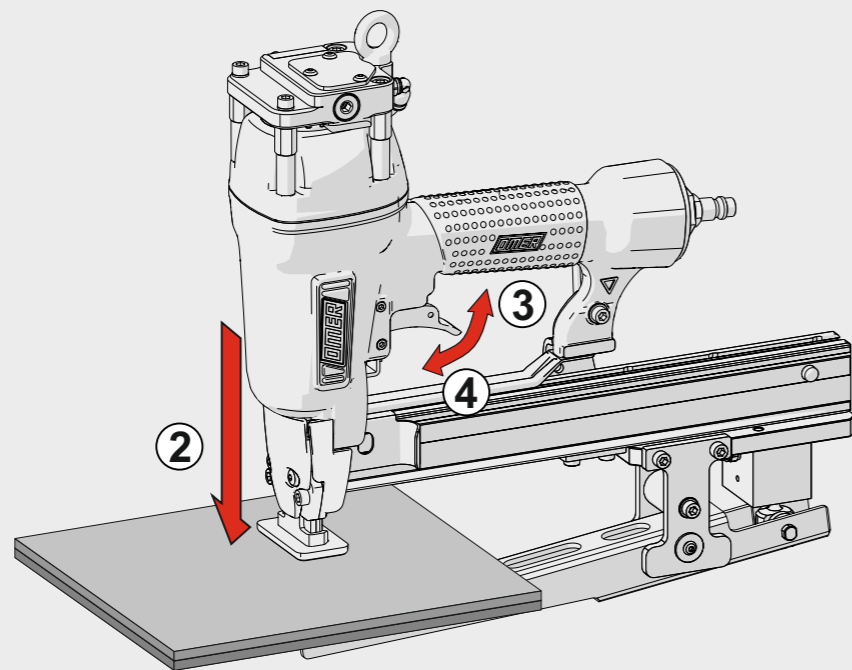
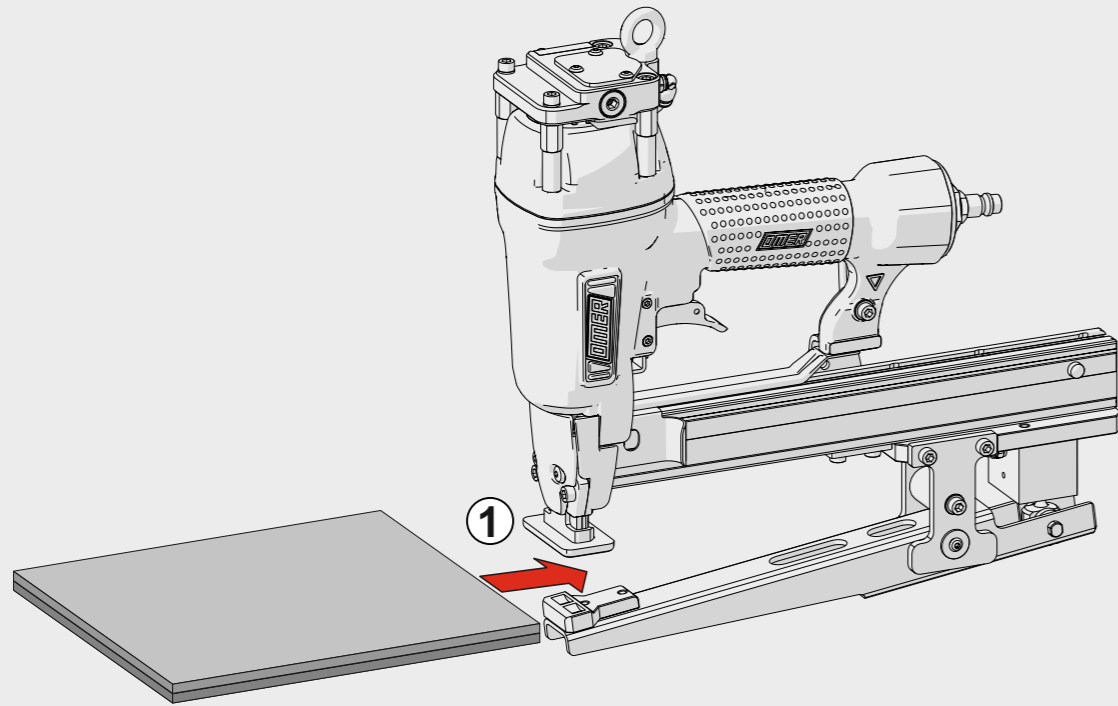

| Cod. | Descrizione | Description |
|----------|----------------------|---------------------|
| 00.07 | O-Ring | O-Ring |
| 00.08 | O-Ring | O-Ring |
| 00.09 | O-Ring | O-Ring |
| 00.11 | O-Ring | O-Ring |
| 00.13 | O-Ring | O-Ring |
| 00.14 | O-Ring | O-Ring |
| 00.15.2 | O-Ring | O-Ring |
| 00.16 | O-Ring | O-Ring |
| 00.18 | O-Ring | O-Ring |
| 00.21 | O-Ring | O-Ring |
| 00.22 | O-Ring | O-Ring |
| 00.24 | O-Ring | O-Ring |
| 00.45 | O-Ring | O-Ring |
| 01.35 | O-Ring | O-Ring |
| 01.48 | O-Ring | O-Ring |
| 01.51 | O-Ring | O-Ring |
| 01.64 | O-Ring | O-Ring |
| 02.38.2 | O-Ring | O-Ring |
| 02.48 | O-Ring | O-Ring |
| 03.00 | Dado | Nut |
| 03.30 | Vite | Screw |
| 04.00 | Dado | Nut |
| 04.05.5 | Vite | Screw |
| 04.10 | Vite | Screw |
| 04.12 | Vite | Screw |
| 04.16.1 | Vite | Screw |
| 04.19 | Vite | Screw |
| 05.00 | Dado | Nut |
| 05.00.1 | Dado | Nut |
| 05.10 | Vite | Screw |
| 05.14 | Vite | Screw |
| 05.16.1 | Vite | Screw |
| 05.16.1 | Vite | Screw |
| 05.20 | Vite | Screw |
| 05.25 | Vite | Screw |
| 05.35 | Vite | Screw |
| 05.38.5 | Vite | Screw |
| 06.12.7 | Vite | Screw |
| 06.20 | Vite | Screw |
| 06.20.2 | Vite | Screw |
| 07.25 | Chiave esagonale | Hex. bar wrench |
| 07.30 | Chiave esagonale | Hex. bar wrench |
| 07.40 | Chiave esagonale | Hex. bar wrench |
| 07.50 | Chiave esagonale | Hex. bar wrench |
| 09.15 | Rondella | Washer |
| 09.24.1 | Anello elastico | Elastic ring |
| 10.55 | O-Ring | O-Ring |
| 17.27 | Tappo | Inlet cap |
| 17.31.5 | Raccordo | Connection |
| 17.34.8 | Tappo | Inlet cap |
| 18.05 | Cilindro pneumatico | Pneumatic cylinder |
| 18.60 | Corpo valvola | Valve body |
| 18.61 | Tappo valvola | Valve cap |
| 18.62 | Pistone servovalvola | Servo valve piston |
| 18.63 | Piastrina | Plate |
| 21.76 | Corpo | Body |
| 22.74-1 | Testa | Head |
| 25.74 | Deflettore scarico | Exhaust deflector |
| 26.74 | Cilindro | Cylinder |
| 27.70 | Anello | Ring |
| 27.74 | Anello cilindro | Cylinder ring |
| 28.74 | Guarnizione testa | Head gasket |
| 30.75.1 | Pistone | Piston |
| 32.75.1 | Ammortizzatore | Bumper |
| 40.74 | Valvola completa | Valve assembled |
| 43.11 | Rondella | Washer |
| 43.16.4 | Rondella | Washer |
| 44.73 | Guarnizione cilindro | Cylinder gasket |
| 44.74 | Ammortizzatore sup. | Upper bumper |
| 45.70 | Distanziale | Spacer |
| 50.74 | Pulsante completo | Trigger valve assy |
| 51.74 | Boccola servovalvola | Servo valve bushing |
| 53.74 | Pistone servovalvola | Servo valve piston |
| 54.83 | Pulsante | Trigger valve |
| 55.74 | Raccordo pulsante | Trigger valve bush |
| 56.70 | Cerniera | Hinge |
| 64.78.1 | Carter sicura | Safety guard |
| 64.79.5 | Carter | Hold down |
| 67.74 | Distanziale | Spacer |
| 67.75 | Distanziale | Spacer |
| 69.75 | Distanziale | Spacer |
| 69.77 | Ribaditore | Reverter |
| 69.79 | Ganascia | Jaw |
| 70.78 | Supporto | Support |
| 71.76 | Reggicaricatore | Support |
| 73.71.2 | Perno | Pin |
| 75.66.5 | Sicura | Safety |
| 76.44 | Rullo molla | Roller |
| 76.72 | Perno | Pin |
| 77.78 | Guida sicura | Safety guide |
| 78.76 | Rinvio sicura | Safety rod |
| 81.78 | Grilletto comando BF | BF Trigger |
| 86.74 | Boccola | Bushing |
| 88.79 | Supporto | Support |
| 90.76.1 | Piastrina | Plate |
| 90.74.4 | Piastrina | Plate |
| 91.00 | Molla | Spring |
| 91.02 | Molla | Spring |
| 91.73 | Molla | Spring |
| 91.74 | Molla | Spring |
| 92.73 | Molla | Spring |
| 93.73 | Molla | Spring |
| 23.72.63 | Battente | Driver |
| 54.72.60 | Caricatore | Magazine |
| 71.70.60 | Spingipunto | Pusher |
| 84.71.63 | Controtestina | Nose |
| 94.70.63 | Testina | Nose plate |
| D01 | Bocchetta olio | Oiler |
| D02 | Occhiali protettivi | Protective goggles |

Guarnizioni - O-Rings - Dichtungen - Joints toriques - Juntas - Δακτύλιος στεγανοποίησης - Vedantes - O-ringen - Contalar

