

Caratteristiche - Features - Merkmale - Caractéristiques - Características - Χαρακτηριστικά - Características - Kenmerken - Özellikler

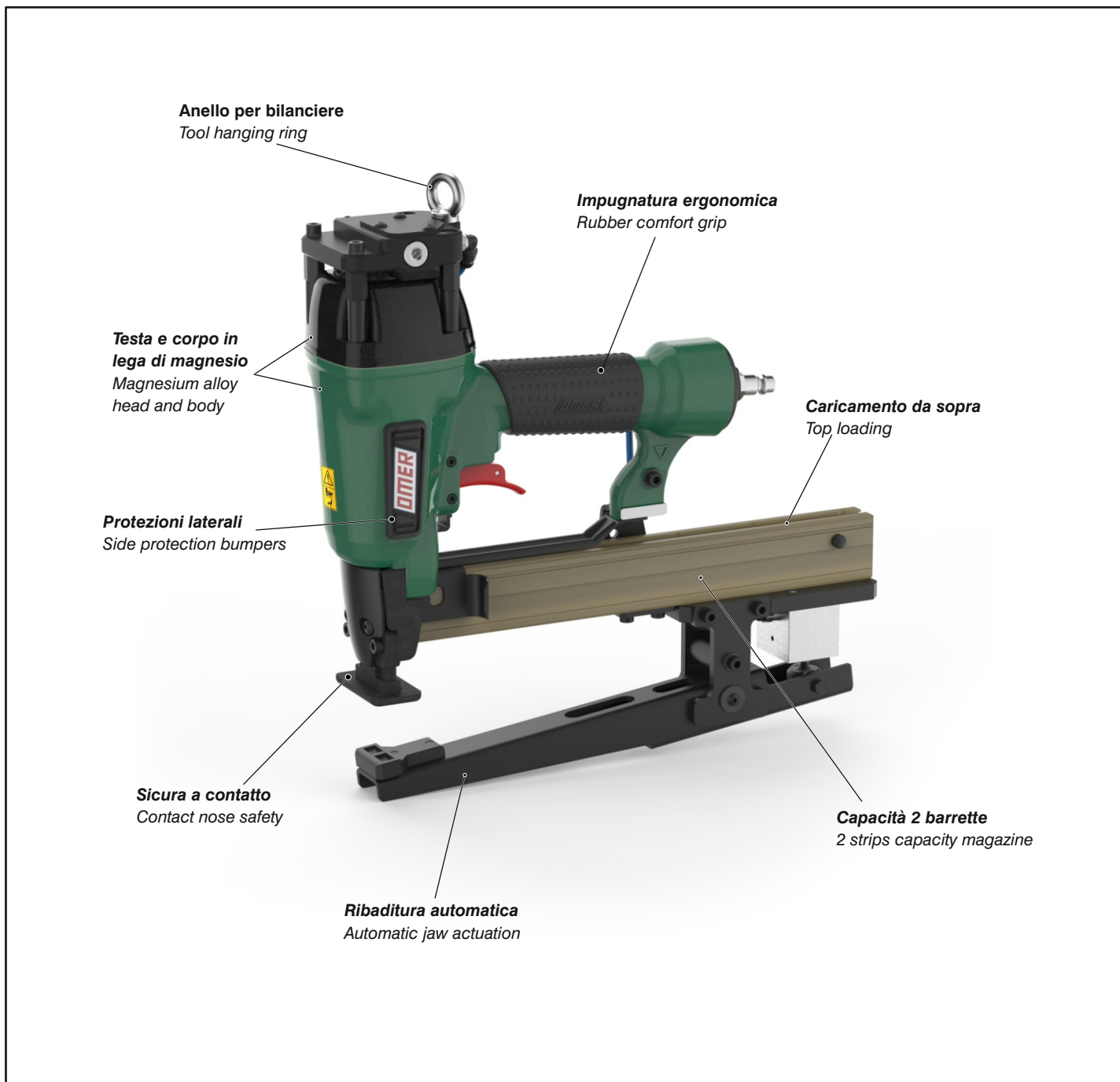

**Manuale d'uso, manutenzione e parti di ricambio**  
**Manual for use, maintenance and spare parts**  
**Bedienungs- und Wartungshandbuch sowie Ersatzteilleiste**  
**Mode d'emploi, de maintenance et pièces de rechange**  
**Manual de uso, mantenimiento y recambios**  
**Εγχειρίδιο χρήσης, συντήρησης και ανταλλακτικών**  
**Manual de uso, manutenção e peças sobresselentes**  
**Handleiding voor gebruik, onderhoud en wisselstukken**  
**Kullanım, bakım ve yedek parça kılavuzu**

**Parte 2**  
**Part 2**  
**Teil 2**  
**Partie 2**  
**Part 2**  
**Μέρος 2**  
**Parte 2**  
**Deel 2**  
**Kısım 2**



**PL WS.738**

cod. 1749510PL

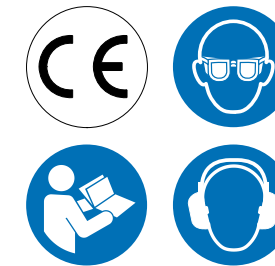

**Warning:** Please read the instructions and warnings for this tool carefully before use. Failure to do so could lead to serious injury.

Dati tecnici Technical data Technische Daten	Caractéristiques techniques Datos técnicos Τεχνικά χαρακτηριστικά	Dados técnicos Technische gegevens Teknik veriler	
<b>Misure impiegabili mm</b> Lengths mm Verwendbare Nagellänge mm	Dimensions utiles mm Medidas de longitud mm Μήκος Αναλωσίμου - mm	Medidas utilizáveis mm Toepasbare afmetingen mm Boy mm	<b>15 ÷ 38</b>
<b>Capacità caricatore n° punti</b> Magazine capacity Magazinkapazität Nägel	Capacité chargeur n° de points Capacidad cargador n° puntos Δωσατοτητα γεμιστερα	Capacidade carregador n° pontos Capaciteit magazijn in aantal spijkers Dergi kapasitesi	<b>150</b>
<b>Pressione d'esercizio</b> Operating pressure Betriebsdruck	Pression d'exercice Presión de servicio Πίεση λειτουργίας	Pressão de serviço Werkdruk Çalışma basıncı	<b>5 ÷ 7,5 bar</b> <b>70 ÷ 105 psi</b>
<b>Consumo aria litri/colpo</b> Air consumption litres/stroke Luftverbrauch Liter/Schuss	Consommation d'air litres/coup Consumo aire litros/golpe Κατανάλωση αέρα - λίτρα/βολή	Consumo ar litros/disparo Luchtverbruik liter/slag Litre/vuruş hava tüketimi	<b>0,75</b>
<b>Peso kg</b> Weight kg Gewicht kg	Poids kg Peso kg Βάρος - kg	Peso kg Gewicht in kg Ağırlık kg	<b>3,40</b>
<b>Dimensioni mm</b> Dimensions mm Abmessungen mm	Dimensions mm Dimensiones mm Διαστάσεις mm	Dimensões mm Afmetingen mm Boyutlar mm	<b>345x77x348</b> (LxWxH)
<b>UNI EN 12549 :2009</b> <b>UNI EN ISO 4871 :2009</b>	<b>Pressione sonora in pos. operatore</b> Sound pressure in operator's position Schalldruck am Arbeitsplatz	Pression sonore poste Opérateur Presión sonora en la pos. del operador Ηχητική πίεση στη θέση του Χειριστή	<b>94 dB(A)</b> (K= 4 dB)
<b>UNI EN 12549 :2009</b> <b>UNI EN ISO 3746 :2011</b> <b>UNI EN ISO 4871 :2009</b>	<b>Potenza sonora emessa</b> Sound power emitted Emittierte Schallleistung	Potência sonora emitida Geëmitteerd geluidsvermogen Çıkan ses gücü (ses desibel)	<b>103 dB(A)</b> (K= 4 dB)
<b>UNI CEN ISO/TS 8662-11 :2006</b> <b>UNI EN ISO 5349-2 :2004</b> <b>UNI EN 12096 :1999</b>	<b>Emissione vibratoria sull'impugnatura</b> Vibratory emissions on handle Vibrationsemission am Griff	Émission vibratoire sur la prise en main Emisión de vibraciones en la empuñadura Εκπεμπόμενες δονήσεις στη λαβή	<b>4,19 m/s<sup>2</sup></b> (K= 2 m/s <sup>2</sup> )

**Tipo di punto**  
 Type of fastener  
 Befestigungsmittel  
 Type de rivet  
 Tipo de punto  
 Τύπος αναλωσίμου  
 Tipo de agrafo  
 Type nietjes  
 Zimba ve çivi tipleri

**WS**

1,40x1,60

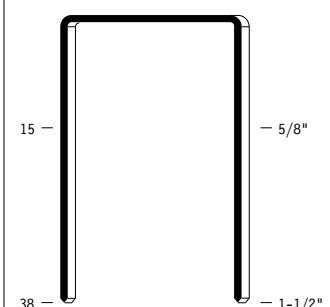

Crown: .982" (1")  
 Gauge: 16



**Azionamento a contatto**  
Contact actuation

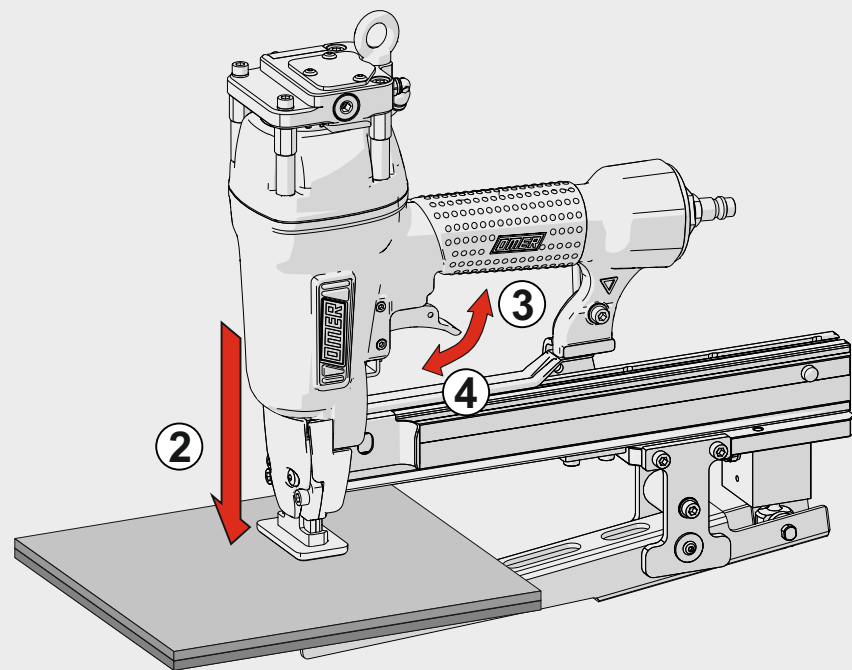
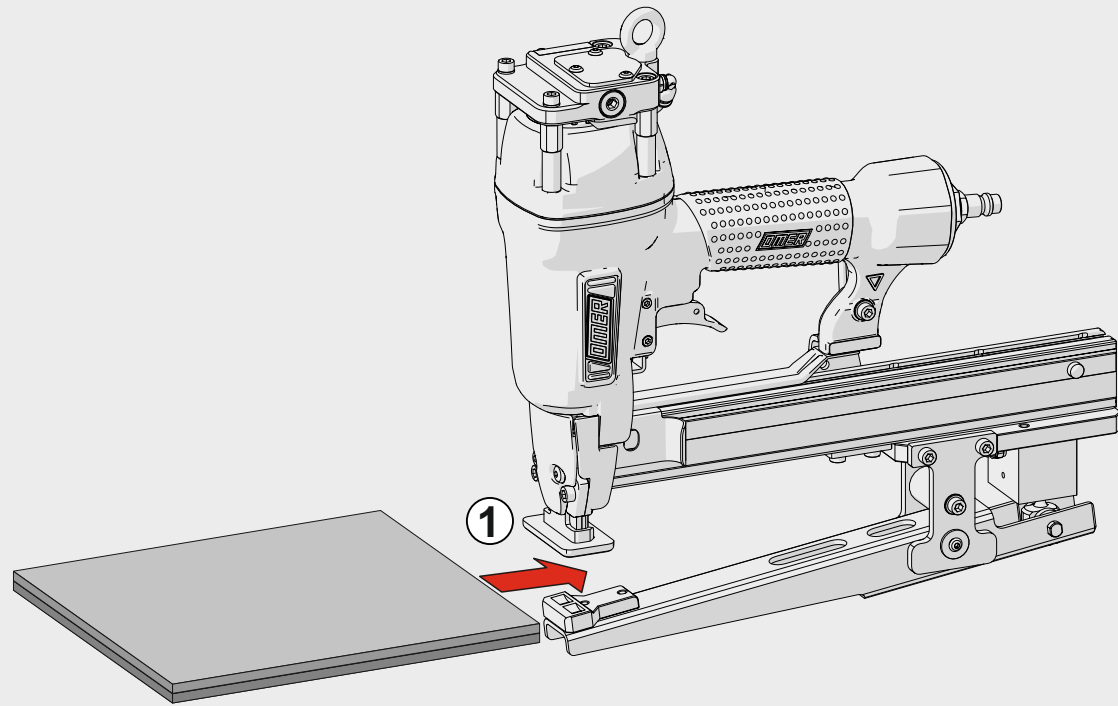

Cod.	Descrizione	Description
00.07	O-Ring	O-Ring
00.08	O-Ring	O-Ring
00.09	O-Ring	O-Ring
00.11	O-Ring	O-Ring
00.13	O-Ring	O-Ring
00.14	O-Ring	O-Ring
00.15.2	O-Ring	O-Ring
00.16	O-Ring	O-Ring
00.18	O-Ring	O-Ring
00.21	O-Ring	O-Ring
00.22	O-Ring	O-Ring
00.24	O-Ring	O-Ring
00.45	O-Ring	O-Ring
01.35	O-Ring	O-Ring
01.48	O-Ring	O-Ring
01.51	O-Ring	O-Ring
01.64	O-Ring	O-Ring
02.38.2	O-Ring	O-Ring
02.48	O-Ring	O-Ring
03.00	Dado	Nut
03.30	Vite	Screw
04.00	Dado	Nut
04.05.5	Vite	Screw
04.10	Vite	Screw
04.12	Vite	Screw
04.16.1	Vite	Screw
04.19	Dado	Nut
05.00	Dado	Nut
05.00.1	Dado	Nut
05.10	Vite	Screw
05.14	Vite	Screw
05.16.1	Vite	Screw
05.16.1	Vite	Screw
05.20	Vite	Screw
05.25	Vite	Screw
05.35	Vite	Screw
05.38.5	Vite	Screw
06.12.7	Vite	Screw
06.20	Vite	Screw
06.20.2	Vite	Screw
07.25	Chiave esagonale	Hex. bar wrench
07.30	Chiave esagonale	Hex. bar wrench
07.40	Chiave esagonale	Hex. bar wrench
07.50	Chiave esagonale	Hex. bar wrench
09.15	Rondella	Washer
09.24.1	Anello elastico	Elastic ring
10.55	O-Ring	O-Ring
17.27	Tappo	Inlet cap
17.31.5	Raccordo	Connection
17.34.8	Tappo	Inlet cap
18.05	Cilindro pneumatico	Pneumatic cylinder
18.60	Corpo valvola	Valve body
18.61	Tappo valvola	Valve cap
18.62	Pistone servovalvola	Servo valve piston
18.63	Piastrina	Plate
21.76	Corpo	Body
22.74-1	Testa	Head
25.74	Deflettore scarico	Exhaust deflector
26.74	Cilindro	Cylinder
27.70	Anello	Ring
27.74	Anello cilindro	Cylinder ring
28.74	Guarnizione testa	Head gasket
30.75.1	Pistone	Piston
32.75.1	Ammortizzatore	Bumper
40.74	Valvola completa	Valve assembled
43.11	Rondella	Washer
43.16.4	Rondella	Washer
44.73	Guarnizione cilindro	Cylinder gasket
44.74	Ammortizzatore sup.	Upper bumper
45.70	Distanziale	Spacer
50.74	Pulsante completo	Trigger valve assy
51.74	Boccola servovalvola	Servo valve bushing
53.74	Pistone servovalvola	Servo valve piston
54.83	Pulsante	Trigger valve
55.74	Raccordo pulsante	Trigger valve bush
56.70	Cerniera	Hinge
64.78.1	Carter sicura	Safety guard
64.79	Carter	Hold down
67.74	Distanziale	Spacer
67.75	Distanziale	Spacer
69.75	Distanziale	Spacer
69.77	Ribaditore	Reverter
69.79	Ganascia	Jaw
70.78	Supporto	Support
71.76	Reggicaricatore	Support
73.71.2	Perno	Pin
75.66.5	Sicura	Safety
76.44	Rullo molla	Roller
76.72	Perno	Pin
77.78	Guida sicura	Safety guide
78.76	Rinvio sicura	Safety rod
81.78	Grilletto comando BF	BF Trigger
86.74	Boccola	Bushing
88.79	Supporto	Support
90.76.1	Piastrina	Plate
90.74.4	Piastrina	Plate
91.00	Molla	Spring
91.02	Molla	Spring
91.73	Molla	Spring
91.74	Molla	Spring
92.73	Molla	Spring
93.73	Molla	Spring
23.72.60	Battente	Driver
54.72.60	Caricatore	Magazine
71.70.60	Spingipunto	Pusher
84.71.60	Controtestina	Nose
94.70.61	Testina	Nose plate
D01	Bocchetta olio	Oiler
D02	Occhiali protettivi	Protective goggles

Guarnizioni - O-Rings - Dichtungen - Joints toriques - Junta - Δακτύλιος στεγανοποίησης - Vedantes - O-ringen - Contalar

