

Scarico orientabile a 360°
360° adjustable exhaust

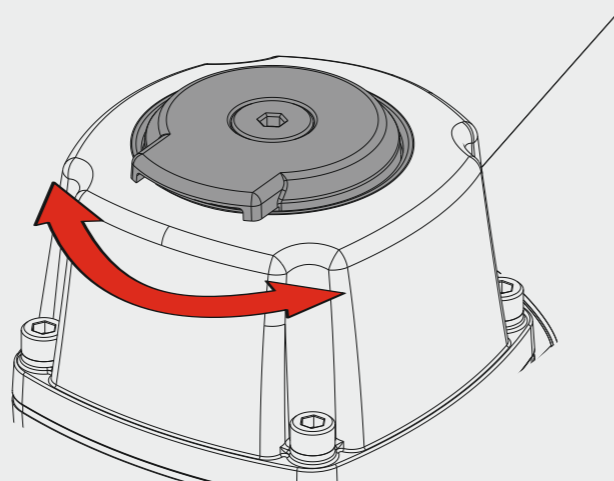

Regolazione di profondità - Depth adjustment - Tiefeneinstellung - Réglage des dimensions - Réglage des dimensions
Ρύθμιση βάθους - Regulação de profundidade - Diepte afstelling - Derinlik ayarı

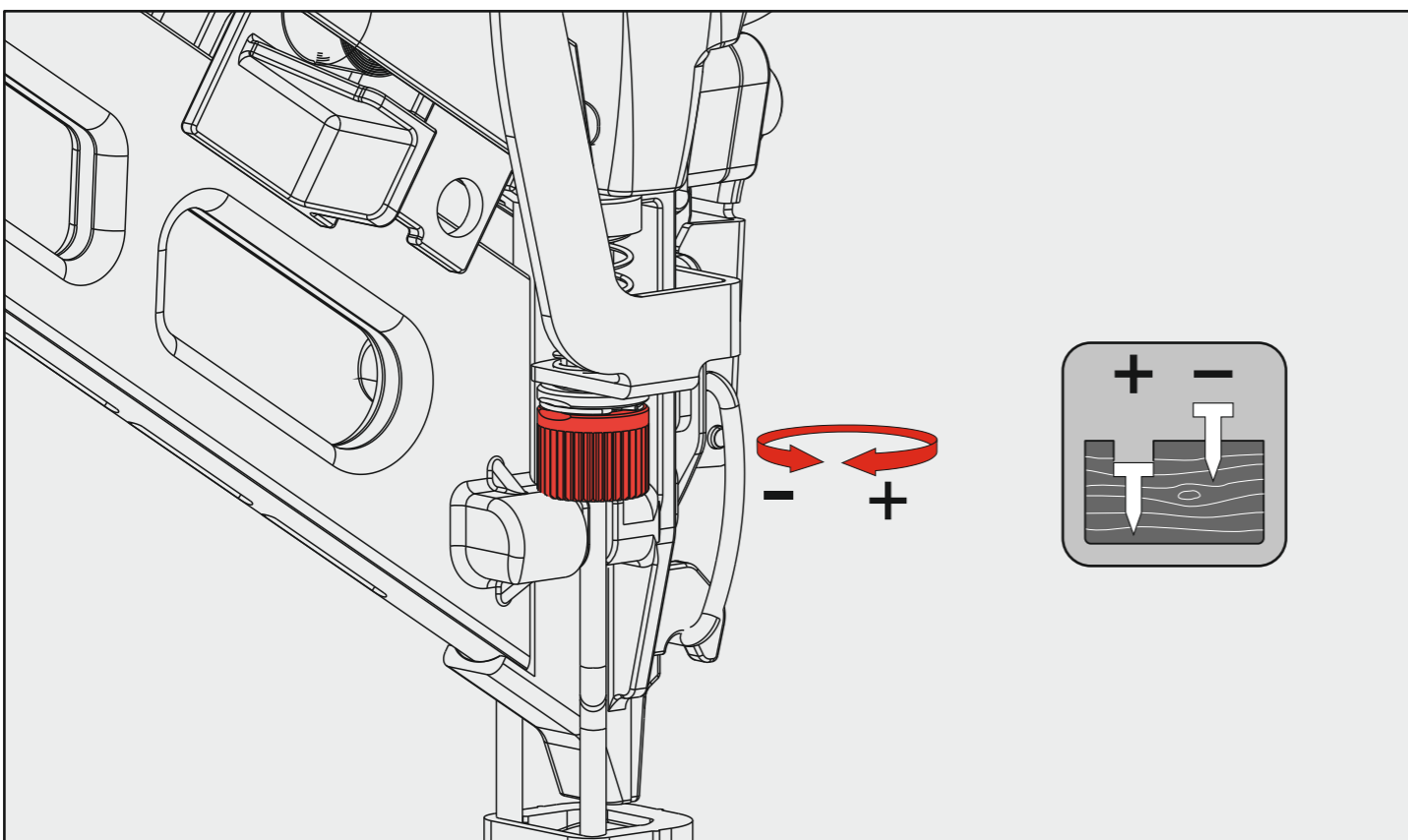

Dotazioni - Equipment - Ausstattung - Outillage - Dotaciones - Εξοπλισμός
Dotações - Uitrusting - Donanımlar

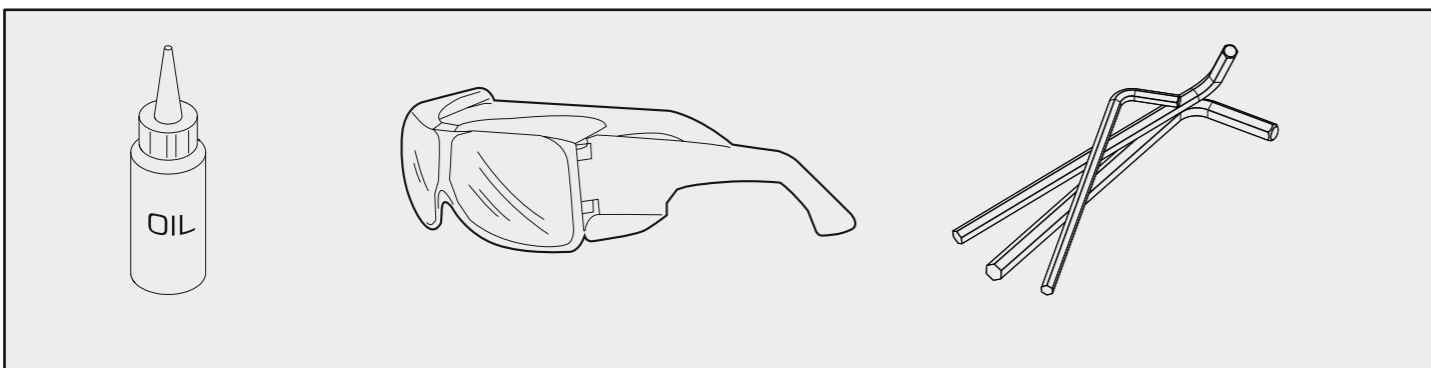

Manuale d'uso, manutenzione e parti di ricambio	Parte 2
Manual for use, maintenance and spare parts	Part 2
Bedienungs- und Wartungshandbuch sowie Ersatzteilliste	Teil 2
Mode d'emploi, de maintenance et pièces de rechange	Partie 2
Manual de uso, mantenimiento y recambios	Part 2
Εγχειρίδιο χρήσης, συντήρησης και ανταλλακτικών	Μέρος 2
Manual de uso, manutenção e peças sobresselentes	Parte 2
Handleiding voor gebruik, onderhoud en wisselstukken	Deel 2
Kullanım, bakım ve yedek parça kılavuzu	Kısım 2



DA.64

cod. 195MDA64A1



Warning: Please read the instructions and warnings for this tool carefully before use. Failure to do so could lead to serious injury.

Dati tecnici Technical data Technische Daten	Caractéristiques techniques Datos técnicos Τεχνικά χαρακτηριστικά	Dados técnicos Technische gegevens Teknik veriler	
Misure impiegabili mm Lengths mm Verwendbare Nagellänge mm	Dimensions utiles mm Medidas de longitud mm Μήκος Αναλωσίμου - mm	Medidas utilizáveis mm Toepasbare afmetingen mm Boy mm	25 ÷ 65
Capacità caricatore n° punti Magazine capacity Magazinkapazität Nägel	Capacité chargeur n° de points Capacidad cargador n° puntos Δωνατοτητα γεμιστερα	Capacidade carregador n° pontos Capaciteit magazijn in aantal spijkers Dergi kapasitesi	150
Pressione d'esercizio Operating pressure Betriebsdruck	Pression d'exercice Presión de servicio Πίεση λειτουργίας	Pressão de serviço Werkdruk Çalışma basıncı	5 ÷ 8 bar 70 ÷ 115 psi
Consumo aria litri/colpo Air consumption litres/stroke Luftverbrauch Liter/Schuss	Consommation d'air litres/coup Consumo aire litros/golpe Κατανάλωση αέρα - λίτρα/βολή	Consumo ar litros/disparo Luchtverbruik liter/slag Litre/vuruş hava tüketimi	1,44
Peso kg Weight kg Gewicht kg	Poids kg Peso kg Βάρος - kg	Peso kg Gewicht in kg Ağırlık kg	1,95
Dimensioni mm Dimensions mm Abmessungen mm	Dimensions mm Dimensiones mm Διαστάσεις mm	Dimensões mm Afmetingen mm Boyutlar mm	349x85x314 (LxWxH)
UNI EN 12549 :2009	UNI EN ISO 4871 :2009		
Pressione sonora in pos. operatore Sound pressure in operator's position Schalldruck am Arbeitsplatz	Pression sonore poste Opérateur Presión sonora en la pos. del operador Ηχητική πίεση στη θέση του Χειριστή	Pressão sonora na posição Operador Geluidsdruk op de werkplaats Operatör pozisyonunda ses basıncı	91,3 dB(A) (K= 2,5 dB)
UNI EN 12549 :2009	UNI EN ISO 3746 :2011	UNI EN ISO 4871 :2009	
Potenza sonora emessa Sound power emitted Emittierte Schallleistung	Puissance sonore émise Potencia sonora emitida Εκπεμπόμενη ηχητική ισχύς	Potência sonora emitida Geëmitteerd geluidsvermogen Çıkan ses gücü (ses desibel)	91,7 dB(A) (K= 2,5 dB)
UNI CEN ISO/TS 8662-11 :2006	UNI EN ISO 5349-2 :2004	UNI EN 12096 :1999	
Emissione vibratoria sull'impugnatura Vibratory emissions on handle Vibrationsemission am Griff	Émission vibratoire sur la prise en main Emisión de vibraciones en la empuñadura Εκπεμπόμενες δονήσεις στη λαβή	Emissão vibratória na empunhadura Trillingsemissie op de handgreep Tutamak üzerinde vibrasyon emisyonları	2,63 m/s² (K= 1,31 m/s ³)

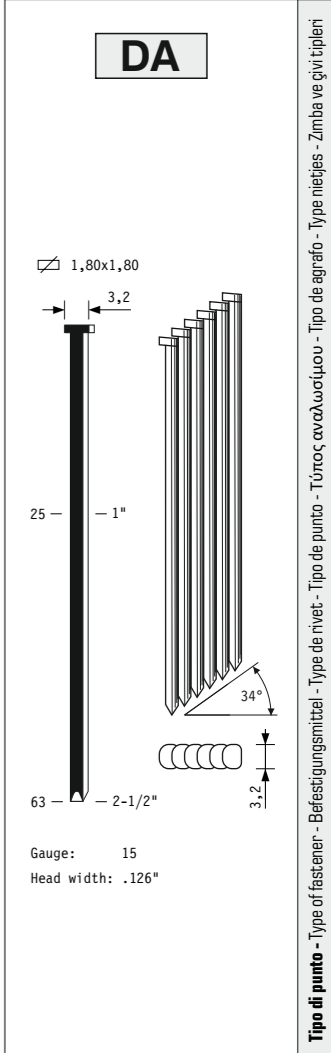

195MDA64A1_DA64_A1_rev20_08/10/2020_LA

Ref. No. Part No. Description

101	2MDB1564-A101	Deflector Bolt
102	2MDB1564-A102	Rubber Pad
103	2MDB1564-A103	Deflector
104	2MCN2970-A104	Hex. Soc. Hd. Screw
105	2MDB1564-A105	Bolt Assy
106	2MDA64-A106	Cap
107	2MDB1564-A107	Cylinder Cap Seal
108	2MDB1564-A108	Compression Spring
109	2MDB1564-A109	O-Ring
110	2MDB1564-A110	O-Ring
111	2MDB1564-A111	Hd.Valve Piston
112	2MDB1564-A112	Collar
113	2MDB1564-A113	Seal
114	2MDB1564-A114	Press Ring
115	2MDB1564-A115	O-Ring
116	2MDB1564-A116	Piston Ring
117	2MDA64-A117	Driver Unit
118	2MDB1564-A118	O-Ring
119	2MDB1564-A119	Cylinder
120	2MCN3165-A123	Cylinder Ring
121	2MDB1564-A121	Bumper
122	2MDB1564-A122	Driver Guide
123	2MDB1564-A123	Cylinder Spacer
124	2MDB1564-A124	O-Ring
200	2MCN3165-A200	Trigger Valve Unit
201	2MCN3165-A201	O-Ring
202	2MCN3165-A202	O-Ring
203	2MCN3165-A203	Plunger Cap
204	2MCN3165-A204	Valve Plunger
205	2MCN3165-A205	O-Ring
206	2MCN3165-A206	O-Ring
207	2MCN3165-A207	Spring
208	2MCN2550-A208	Plunger
209	2MCN3165-A209	O-Ring
210	2MCN3165-A210	Trigger Valve Head
211	2MCN3165-A211	Spring Pin
212	2MCN3165-A213	Spring Pin
213	2MDB1564-A213	Secondary Trigger
214	2MDB1564-A214	Trigger
215	2MCN3390-A215	Spring Pin
216	2MCN3390-A216	Trigger Pivot Pin
217	2MCN3165-A416	Urethan Retainer
219	2MCN3165-A212	Spring Pin
301	2MDA64-A301	Gun Body Unit
302	2MDB1564-A302	Gasket
303	2MDA64-A303	End Cap
304	2MDB1564-A304	Bolt Assy
305	2MCN3165-A304	Dusty Cover
306	2MCN3165-A305	Air Plug
401	2MDA64-A401	Driver Guide
402	2MDA64-A402	Driver Guide Cover B
403	2MDB1564-A403	Bolt Assy
404	2MDB1564-A404	Fixed Pin
405	2MDA64-A405	Driver Guide Cover A
406	2MDB1564-A406	Safety Guide
407	2MDB1564-A407	Safety B
408	2MCN3165-A454	Lock Nut
409	2MDB1564-A409	Safety Spring
410	2MDB1564-A410	Ring
411	2MDB1564-A411	Link Rod
412	2MDB1564-A412	Adjust Axie
414	2MDA64-A414	Safety
415	2MDA64-A415	Protective Casing
416	2MDA64-A416	Spiral Pins
417	2MDB1564-A417	Lock Nut
418	2MDB1564-A418	Lock Handle Unit
419	2MDA64-A419	Magazine A
420	2MDA64-A420	Bolt Assy
421	2MDA64-A421	Steel Channel
422	2MDA64-A422	Magazine B
423	2MDA64-A423	Stop Nail Plate
424	2MDA64-A424	Protecting Hood Cover
425	2MDA64-A425	Pusher
426	2MDB1564-A426	Spring Unit
427	2MDB1564-A427	Pusher Spring
428	2MDA64-A428	Spring Pin
500	2MDB1564-K214	Sequential actuation KIT

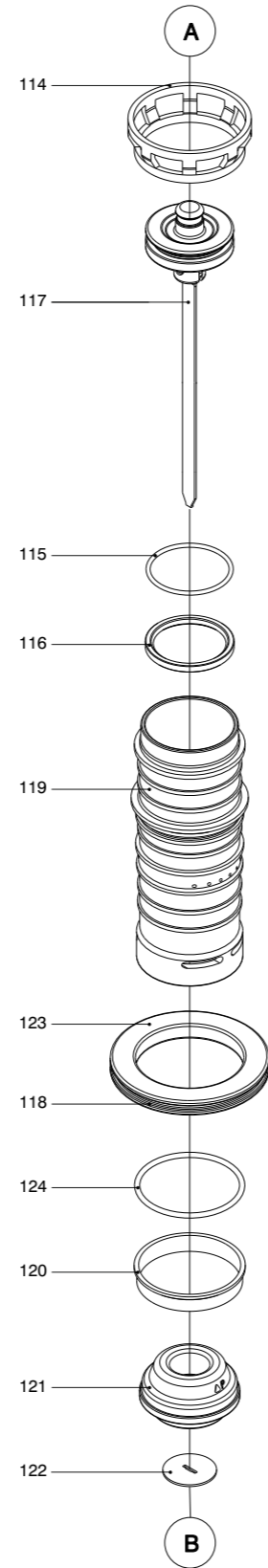
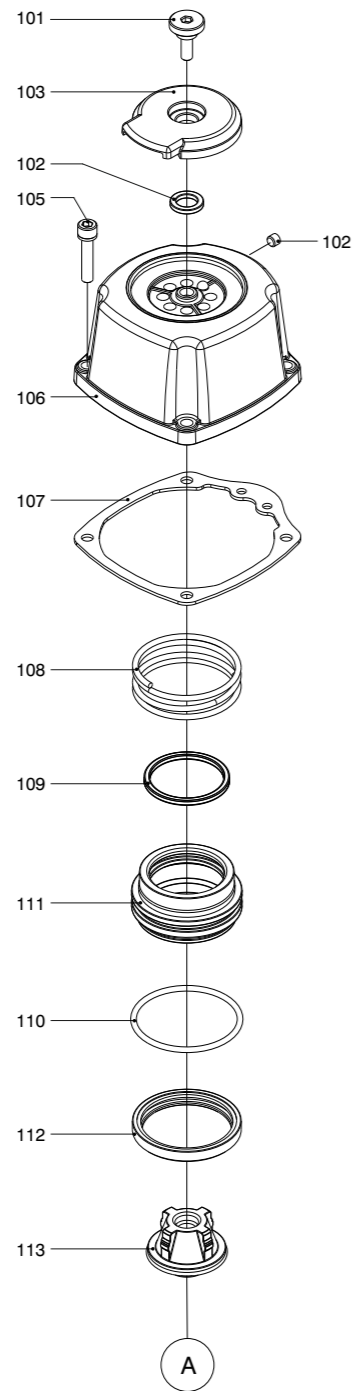

Note - Notes - Hinweise - Remarques - Notas - Σημειώσεις - Observações - Opmerkingen - Notlar

Parti di ricambio - Spare parts - Ersatzteile - Pièces de rechange - Recambios
Ανταλλακτικά - Partes sobresselentes - Wisselstukken - Yedek parçalar

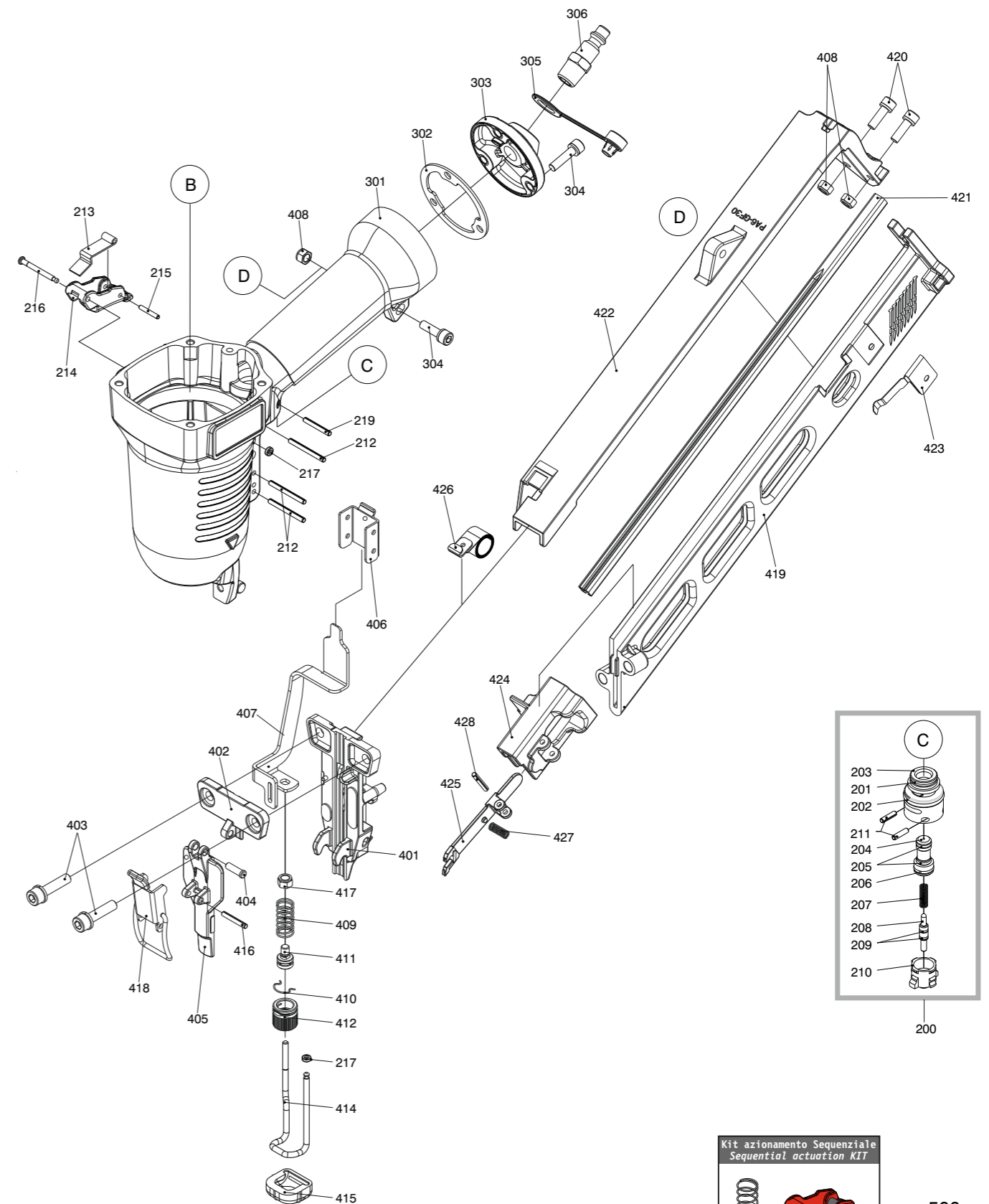
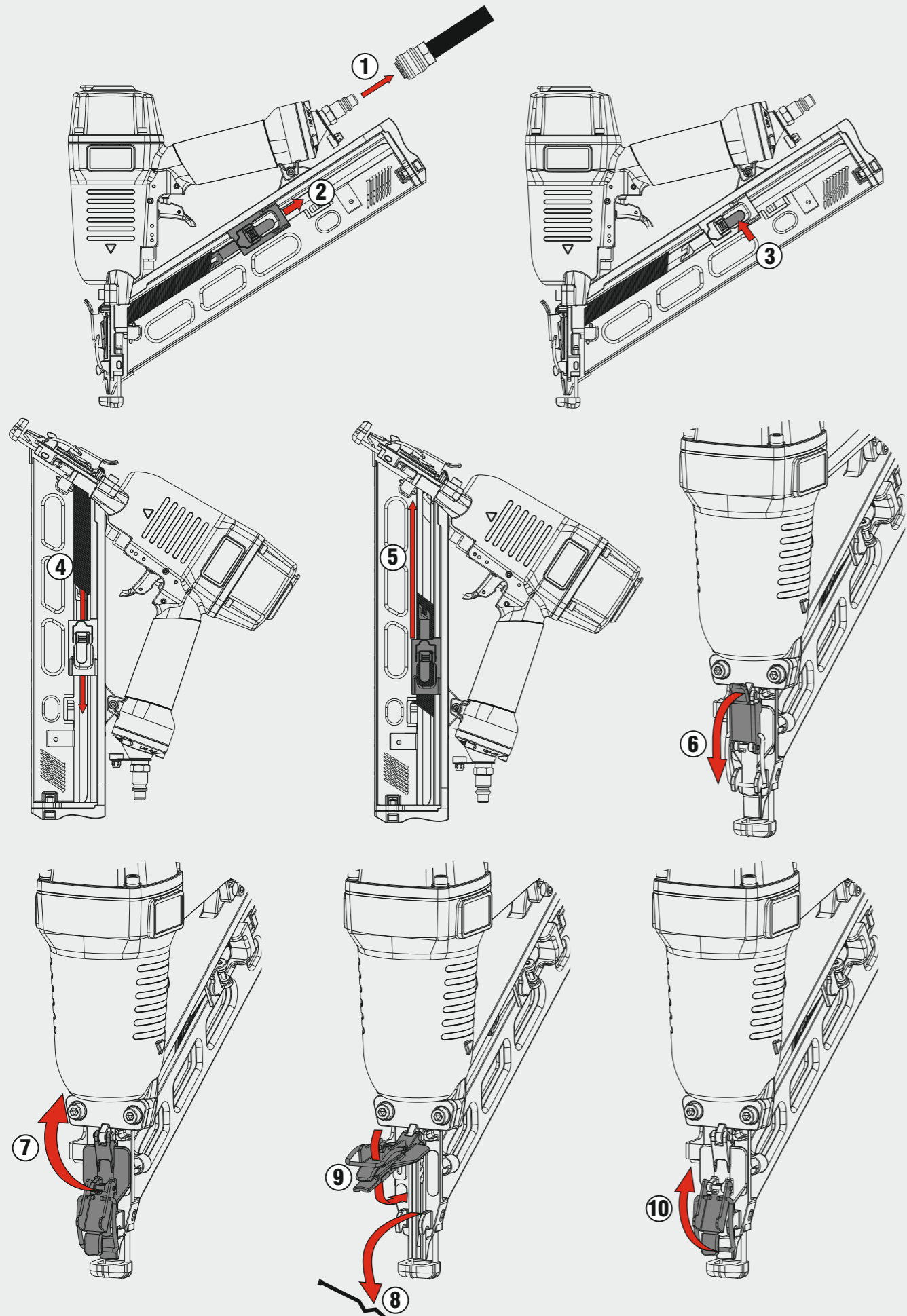

Kit azionamento Sequenziale
 Sequential actuation KIT

A richiesta
 On request

500

DA.64

cod. 195MDA64A1

Indice di modifica
 Upgrade number

A1

Caricamento posteriore
Rear load magazine

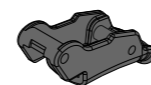
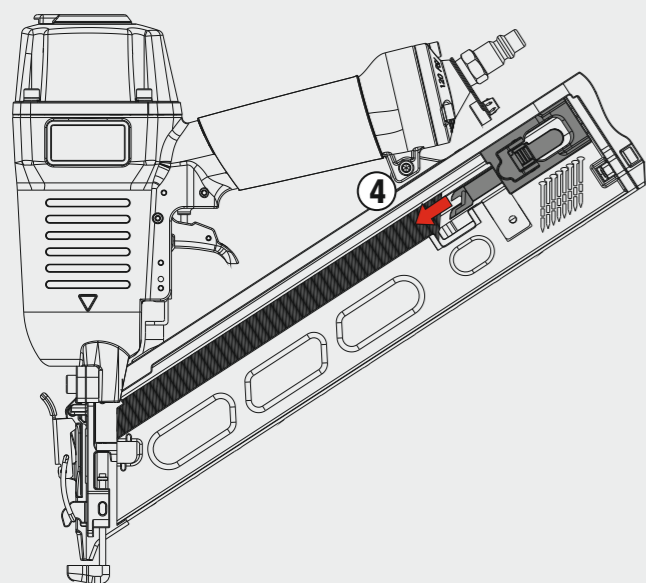
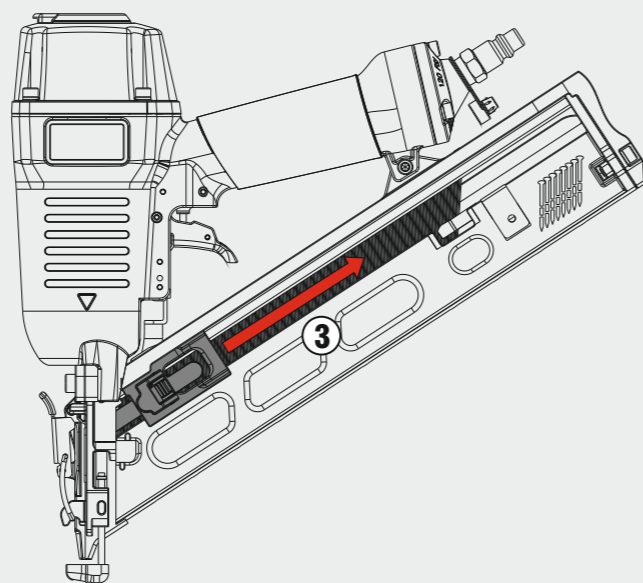
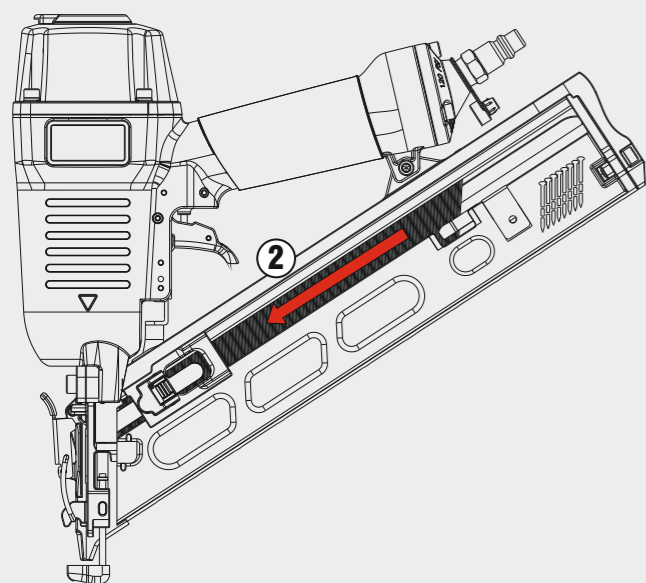
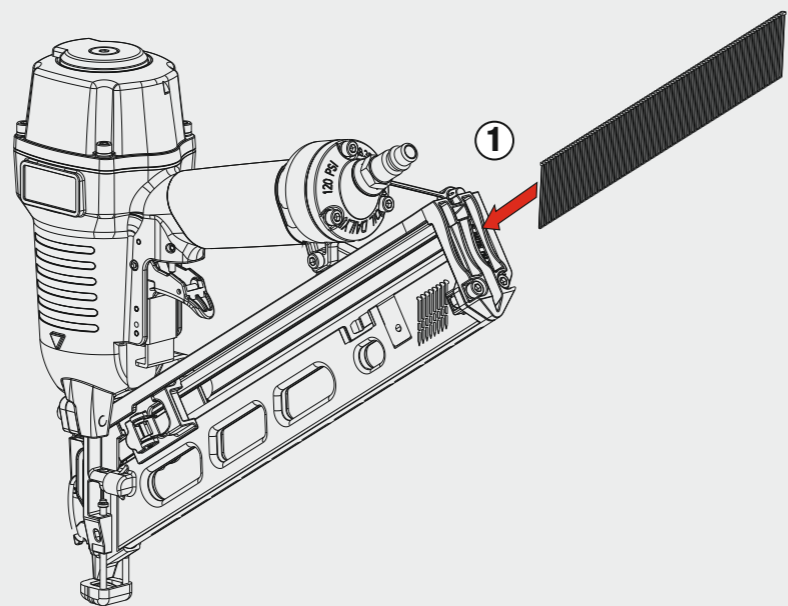

Di serie / Standard

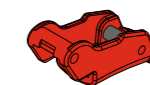

A richiesta / On request

Azionamento a contatto
Contact actuation

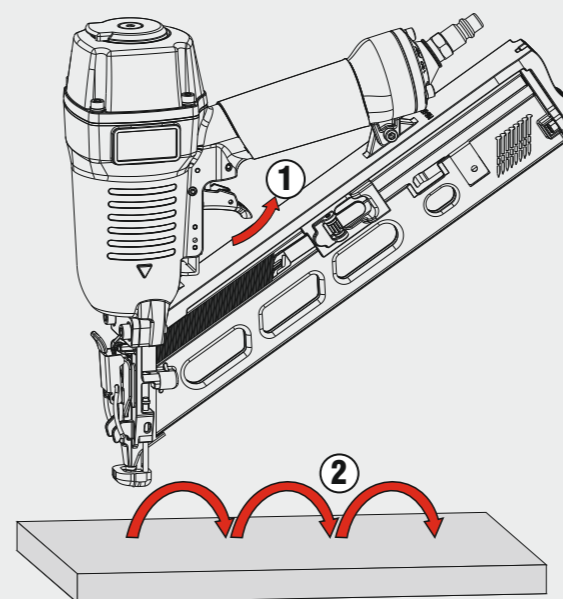

Oppure - Or

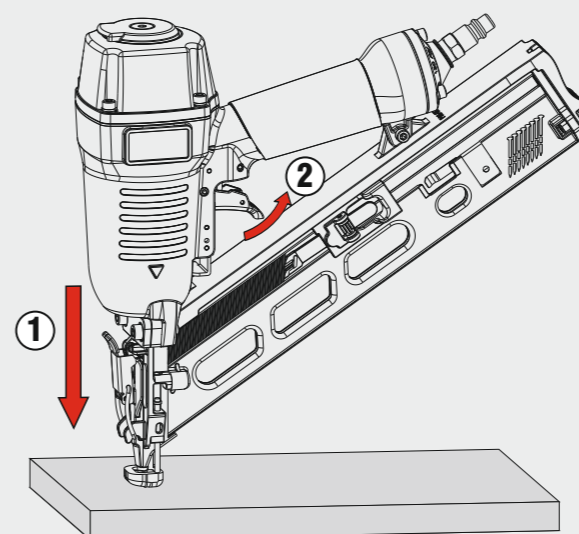

Azionamento sequenziale singolo
Single sequential actuation

